

ANW/ES/RP--92366-Vol. 1

**THE ADVANCE PROJECT:
FORMAL EVALUATION OF THE TARGETED DEPLOYMENT**

VOLUME 1

by

Evaluation Manager
Argonne National Laboratory

Evaluation Teams

Castle Rock Corporation, Inc.
DeLeuw, Cather and Company
Northwestern University Transportation Center
University of Illinois-Chicago, Urban Transportation Center

Sponsored by

U.S. Department of Transportation
Federal Highway Administration
Joint Program Office

MASTER

January 1997

DISTRIBUTION OF THIS DOCUMENT IS UNLIMITED



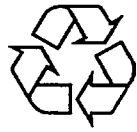

This report is printed on recycled paper.

PREFACE

This document reports on the formal evaluation of the targeted (limited but highly focused) deployment of the **Advanced Driver and Vehicle Advisory Navigation ConcEpt (ADVANCE)**, an in-vehicle advanced traveler information system designed to provide shortest time route guidance. Argonne National Laboratory (ANL) served as the Evaluation Manager. Organizations that assisted in the evaluations of the various subsystems under test plans developed by Booz•Allen & Hamilton, a support contractor to the Federal Highway Administration's Intelligent Transportation System Field Operations Test program, were the University of Illinois at Chicago Urban Transportation Center (UIC-UTC), Northwestern University Transportation Center (NUTC), and DeLeuw, Cather & Company.

This report contains the results of the targeted evaluation in three volumes. Volume 1 presents the Evaluation Manager's Overview Report prepared by ANL. The overview presents the scope of the evaluation, the data collection protocols, a synopsis of the findings, and a discussion of the validity of the targeted deployment's results. Volume 1 also contains Appendixes A through H. Volume 2 contains Appendixes I, J, and K. Volume 3 contains Appendixes L and M.

The appendixes contain the evaluation test results. The reports of each evaluating organization have been presented in the version received from their respective authors, following completion of the technical and policy reviews conducted according to procedures set by the project's Steering Committee. Appendixes A-G were prepared by UIC-UTC; Appendixes H-J were prepared by NUTC; and Appendixes K and L were prepared by DeLeuw, Cather. Appendix M is a glossary of terms used in these reports, as compiled by ANL.

DISCLAIMER

Portions of this document may be illegible in electronic image products. Images are produced from the best available original document.

DOCUMENT CONTENTS

Volume 1

Disclaimer

Preface

Acknowledgments

The *ADVANCE* Participants

Field Test Evaluation Developers, Management, and Staff

Abbreviations and Acronyms

Executive Summary

The *ADVANCE* Targeted Deployment: The Evaluation Manager's Overview Report

Section 1 Genesis of the Targeted Deployment and Its Formal Evaluation

Section 2 Scope and Structure of the Evaluation

Section 3 Early Resource, Physical, and Institutional Challenges to Evaluation

Section 4 Data Collection Activities and Protocols of the Evaluation Field Tests

Section 5 Evaluation Data Collected and Archived

Section 6 Lessons of the Partnership and the Targeted Deployment Test Process

Section 7 The Evaluation Test Reports: A Synopsis of Findings

Section 8 The Effectiveness of Probes: A Key Test of the Targeted Deployment

Section 9 Are the Targeted Deployment's Results Valid and Transferable?

Section 10 The Legacy of *ADVANCE*: The GCM Corridor and Beyond

The Evaluation Test Results

Appendix A Base Data and Static Profile Evaluation Report

Appendix B Data Screening Evaluation Report

Appendix C Quality of Probe Reports Evaluation Report

Appendix D Travel Time Prediction and Performance of Probe and
Detector Data Evaluation Report

Appendix E Detector Travel Time Conversion and Fusion of Probe and
Detector Data Evaluation Report

Appendix F Frequency of Probe Reports Evaluation Report

Appendix G Relationships among Travel Times Evaluation Report

Appendix H Evaluation of Arterial Probe Vehicle, Fixed Detector and Expressway
Fixed Detector Incident Detection Algorithm Evaluation Report

DOCUMENT CONTENTS (Cont.)

VOLUME 2

Disclaimer

Preface

The *ADVANCE* Participants

Field Test Evaluation Developers, Management, and Staff

Abbreviations and Acronyms

The Evaluation Test Results (Cont.)

Appendix I Familiar Driver Perspectives on *ADVANCE* and Future Dynamic Route Guidance Systems Evaluation Report

Appendix J Field Test of the Effectiveness of *ADVANCE* Dynamic Route Guidance on a Suburban Arterial Street Network Evaluation Report

Appendix K TIC Architecture and User Interface Evaluation Report

VOLUME 3

Disclaimer

Preface

The *ADVANCE* Participants

Field Test Evaluation Developers, Management, and Staff

Abbreviations and Acronyms

The Evaluation Test Results (Cont.)

Appendix L System Overview: Insights and Achievements

Appendix M Glossary of ITS and Related Terms Used in these and Other *ADVANCE* Reports

CONTENTS-VOLUME 1

| | |
|---|---------|
| PREFACE | V1-iii |
| DOCUMENT CONTENTS | V1-v |
| CONTENTS-VOLUME 1 | V1-vii |
| FIGURES-OVERVIEW REPORT | V1-ix |
| ACKNOWLEDGMENTS | V1-x |
| THE <i>ADVANCE</i> PARTICIPANTS | V1-xi |
| FIELD TEST EVALUATION DEVELOPERS, MANAGEMENT, AND STAFF | V1-xii |
| ABBREVIATIONS AND ACRONYMS | V1-xiii |
| EXECUTIVE SUMMARY | S-1 |

THE *ADVANCE* TARGETED DEPLOYMENT: THE EVALUATION MANAGER'S OVERVIEW REPORT

| | |
|---|----|
| 1 GENESIS OF THE TARGETED DEPLOYMENT AND ITS FORMAL EVALUATION | 1 |
| 2 SCOPE AND STRUCTURE OF THE EVALUATION | 4 |
| 2.1 TRF Subsystem | 4 |
| 2.2 MNA Subsystem | 8 |
| 2.3 TIC Subsystem | 11 |
| 2.4 COM Subsystem | 13 |
| 3 EARLY RESOURCE, PHYSICAL, AND INSTITUTIONAL CHALLENGES TO EVALUATION | 15 |
| 4 DATA COLLECTION ACTIVITIES AND PROTOCOLS OF THE EVALUATION FIELD TESTS | 17 |
| 4.1 Evaluation of TRF | 17 |
| 4.2 DRG/YD and ID Evaluations | 18 |
| 4.3 Real-Time Data Retrieval Tracking | 20 |
| 4.4 Data Capture and Archiving: Daily Test Logs | 20 |
| 4.5 Data Capture and Archiving: Memory Card Files | 21 |
| 4.6 Familiar Driver Data Collection Instruments | 21 |

CONTENTS-VOLUME 1 (Cont.)

| | | |
|------|--|----|
| 5 | EVALUATION DATA COLLECTED AND ARCHIVED | 22 |
| 6 | LESSONS OF THE PARTNERSHIP AND THE TARGETED DEPLOYMENT TEST PROCESS | 24 |
| 7 | THE EVALUATION TEST REPORTS: A SYNOPSIS OF FINDINGS | 29 |
| 7.1 | Base Data and Static Profile | 29 |
| 7.2 | Data Screening | 29 |
| 7.3 | Quality of Probe Reports | 30 |
| 7.4 | Travel Time Prediction and Performance of Probe and Detector Data | 30 |
| 7.5 | Detector Travel Time Conversion and Fusion of Probe and Detector Data | 31 |
| 7.6 | Frequency of Probe Reports | 32 |
| 7.7 | Relationships Among Travel Times | 32 |
| 7.8 | Evaluation of Arterial Probe Vehicle, Fixed Detector and Expressway Fixed Detector Incident Detection Algorithm | 33 |
| 7.9 | Familiar Driver Perspectives on <i>ADVANCE</i> and Future Dynamic Route Guidance Systems | 34 |
| 7.10 | Field Test of the Effectiveness of <i>ADVANCE</i> Dynamic Route Guidance on a Suburban Arterial Street Network | 35 |
| 7.11 | TIC Architecture and User Interface | 36 |
| 8 | THE EFFECTIVENESS OF PROBES: A KEY TEST OF THE TARGETED DEPLOYMENT | 38 |
| 9 | ARE THE TARGETED DEPLOYMENT'S RESULTS VALID AND TRANSFERABLE? | 40 |
| 10 | THE LEGACY OF <i>ADVANCE</i> : THE GCM CORRIDOR AND BEYOND | 42 |

CONTENTS-VOLUME 1 (Cont.)

THE EVALUATION TEST RESULTS

| | | |
|------------|--|-----|
| APPENDIX A | Base Data and Static Profile Evaluation Report | A-1 |
| APPENDIX B | Data Screening Evaluation Report | B-1 |
| APPENDIX C | Quality of Probe Reports Evaluation Report | C-1 |
| APPENDIX D | Travel Time Prediction and Performance of Probe and Detector Data Evaluation Report | D-1 |
| APPENDIX E | Detector Travel Time Conversion and Fusion of Probe and Detector Data Evaluation Report | E-1 |
| APPENDIX F | Frequency of Probe Reports Evaluation Report | F-1 |
| APPENDIX G | Relationships among Travel Times Evaluation Report | G-1 |
| APPENDIX H | Evaluation of Arterial Probe Vehicle, Fixed Detector and Expressway Fixed Detector Incident Detection Algorithm Evaluation Report | H-1 |

FIGURES-OVERVIEW REPORT (VOLUME 1)

| | | |
|---|---|---|
| 1 | Dynamic Information Flow in <i>ADVANCE</i> | 2 |
| 2 | Primary Route Used in TRF Field Tests | 6 |
| 3 | Example Origin-Destination Pair for Yoked Driver Test | 7 |

ACKNOWLEDGMENTS

Preparation of this project report was made possible by sponsorship of the U.S. Department of Transportation, Federal Highway Administration, Intelligent Transportation Systems (ITS) Joint Program Office, Operational Test Program; the participation of Argonne National Laboratory (ANL) under contract as project evaluation manager was made possible by an interagency agreement through U.S. Department of Energy Contract W-31-109-ENG-38. The compiler of this project report wishes to extend gratitude for cooperation and assistance provided throughout the targeted deployment evaluation process to Mr. Joseph F. Ligas, ITS Program Director, and the staff of the *ADVANCE* project office and its support contractor, DeLeuw, Cather & Company; to past and present staff of Motorola, especially Mr. Ray Makaras, for unstinting attention to the needs of the field testing program, including equipment installation and maintenance on rental vehicles; and to the evaluation teams from the University of Illinois at Chicago and Northwestern University for their diligence in carrying out the field tests and preparing the evaluation reports in a thorough and professional manner. The individuals composing these teams are recognized below.

THE ADVANCE PARTICIPANTS

Founding Parties and Members

American Automobile Association
Federal Highway Administration
Illinois Department of Transportation
Illinois Universities Transportation
Research Consortium
Motorola

Associates

Ford Motor Company
General Motors Corporation
Sun Microsystems, Inc.
Surface Systems, Inc.

Sponsors

AB Volo Technical Development
Cellular One
DonTech
Etak, Inc.
Honda R&D North America, Inc.
Illinois State Toll Highway Authority
Institute of Transportation,
Taiwan, Republic of China
Metro Traffic Control
Mercedes-Benz of North America
National Center for
Supercomputing Applications
Navigation Technologies
Nissan Research & Development, Inc.
Pace
Peugot S.A.
Rational
Renault
Toyota Technical Center, Inc.

Contributors

INRO/University of Montreal (CRT)
SAAB
Seagate Technologies
Venkatesh Kambhammettu
Versant Object Technology

Contractors/Technical Support

Aldridge Electric, Inc.
Argonne National Laboratory
Battelle, Inc.
Booz•Allen & Hamilton, Inc.
Castle Rock Corporation, Inc.
De Leuw, Cather & Company
Deborah Gordon Public Relations
Econolite Control Products, Inc.
IBI Group
Metro Transportation Group, Inc.
MITRETEK Systems
National Highway Traffic Safety
Administration
Science Applications International
Corporation
SEI Information Technology
The Blackstone Group
University of Iowa
Volpe National Transportation
Systems Center

FIELD TEST EVALUATION DEVELOPERS, MANAGEMENT, AND STAFF

For Argonne National Laboratory

Project Manager: Adrian Tentner

Evaluation Manager: Christopher Saricks

Associates, Contributors, and Reviewers: Don Rote, Mara Krinke, Greg Chisholm,
Bob Baker, Jeffrey Slater, Thomas Taxon, James Boyle, Ulf Hannebute, Yung Liu,
Richard Simms, Constantine Tzanos, Arthur Wright

For Northwestern University

Principal Investigators: Frank Koppelman, Joseph L. Schofer

Test Managers: Regina G. Webster, Frank Koppelman, Joseph L. Schofer

On-Site Operators and Monitors: William A. Charlton, Michael P. Johnson,
Wei-Hsin Lin, Tsai-Shiou Peng, Daniel Schofer, Tanay Shah, Chien-Hua Wen

Test Drivers: Katherine Anderson, Aaron Boucher, Daniel R. Bober, William DiBella,
Stephen Donohue, Kenneth Ferro, Warren Gelfand, Joan Joseph,
Michael Kenworthy, Joseph Kilgore, Eric Lathrop, Herman Leon,
Julius Longshaw, Holly Miner, Kenneth Noga, Robert Oberwetter,
Margaret Pasquini, Mari-Ann Pollu, Steve Rago, George Ranallo,
Marie Renallo, Lisa Senner, Anne Stapleton, Ernest Stephan, Jason Stobbe,
Lance Tiedemann, Ted Tran, Robert Wolf, Wally Wood

For the University of Illinois at Chicago

Principal Investigators: Ashish Sen, Siim Sööt

Test Manager: Siim Sööt

Field Managers: Stanislaw Berka, Helen Condie, Mark Mathes, Scott Stelzer

Test Drivers (throughout project): Megan Anderson, Kevin Curtin, Margaret Curtin,
Douglas Deckert, Robert Donahue, Yevgeniy Dymarskiy, Tamara Haskins,
Erik Jalakas, Michael Kenworthy, James Andrew Lee, Arthur R. Miller,
Kundan Patel, Mari-Ann Pollu, Ashley Snyder, Marika Sööt, Lance Tiedemann,
Theodore Tran, Robert Wolfe

For Booz•Allen & Hamilton

Test Co-Developers and Technical Reviewers: Paul Bellela, Michael Klassen,
Charles Minehan

For MITRETEK Systems

Technical Reviewer: Richard Bolczak

ABBREVIATIONS AND ACRONYMS

| | |
|----------------|--|
| AAA | American Automobile Association |
| AASHTO | American Association of State Highway Transportation Officials |
| ACG | Access Control Gateway |
| ADIS | Advanced Driver Information Systems |
| ADV | <i>ADVANCE</i> System |
| <i>ADVANCE</i> | Advanced Driver and Vehicle Advisory Navigation ConcEpt |
| AHAR | Automatic Highway Advisory Radio |
| AI | Artificial Intelligence |
| ANR | <i>ADVANCE</i> Network Representation |
| ANSI | American National Standards Institute |
| APTS | Advanced Public Transportation Systems |
| ASCII | American Standard Code for Information Interchange |
| ATC | Automated (electronic) Toll Collection |
| ATIS | Advanced Traveler Information Systems |
| ATMS | Advanced Traffic Management Systems |
| AVI | Automatic Vehicle Identification |
| AVL | Automated Vehicle Location system |
| AVLM | Automatic Vehicle Locating and Monitoring |
| | |
| BD | Base Data |
| BSC | Base Station Controller |
| | |
| CASE Tools | Computer Aided Software Engineering Tools |
| CATS | Chicago Area Transportation Study |
| CCTV | Closed Circuit TV |
| CCVE | Closed Circuit Video Equipment |
| CD-ROM | Compact Disk-Read Only Memory |
| CLSS | Closed Loop Signal System |
| COM | RF communications subsystem of <i>ADVANCE</i> |
| COM.1 | RF Coverage Component of the RF Communications Network |
| COM.2 | Fixed Communications Interface |
| COM.3 | Mobile Communications Interface |
| CRC | CRC Corp. Ltd. (Castle Rock Consultants), subconsultants to DeLeuw, Cather & Co. |
| CRC Bytes | Cyclic Redundancy Check bytes |
| CSMA | Collision Sense Multiple Access |
| C-TIC | Corridor Transportation Information Center |
| CTS | Clear to Send |
| CVO | Commercial Vehicle Operations |

| | |
|--------|--|
| DAT | Digital Audio Tape |
| DB | Data Base |
| DBMS | Data Base Management System |
| DCCO | De Leuw, Cather & Company |
| DDS | Detail Design Specification Document #8600 |
| DF | Data Fusion |
| DIME | Dual Incidence Matrix Encoded files |
| DRGS | Dynamic Route Guidance System |
| DS | Data Screening |
| DSR | Data Set Ready |
| DTE | Data Terminal Equipment |
| DTR | Data Terminal Ready |
| DTTC | Detector Travel Time Conversion |
| ERS | Emergency Response Service |
| ETC | Electronic Toll Collection |
| ETTM | Electronic Toll and Traffic Management |
| FCC | Federal Communications Commission |
| FHWA | Federal Highway Administration |
| FTP | File Transfer Protocol |
| GCM | Gary-Chicago-Milwaukee |
| GDS | General Design Specification, Document #8500 |
| GIS | Geographic Information System |
| GPS | Global Positioning System |
| GUI | Graphical User Interface |
| HAR | Highway Advisory Radio |
| HOV | High Occupancy Vehicle |
| HTTP | Hypertext Transfer Protocol |
| HUFSAM | Highway Users Federation for Safety and Mobility |
| HVAC | Heating, Ventilation, Air Conditioning |
| IBI | IBI Group, Subconsultants to De Leuw, Cather & Company |
| ICS | Interface Control Specification, Document #8110 |
| ID | Incident Detection |
| IDOT | Illinois Department of Transportation |
| IEEE | Institute of Electrical and Electronics Engineers |
| ISTEA | Intermodal Surface Transportation Efficiency Act |
| ITE | Institute of Transportation Engineers |
| ITS | Intelligent Transportation Systems |
| IUTRC | Illinois Universities Transportation Research Consortium |

| | |
|---------|--|
| LAN | Local Area Network |
| LCD | Liquid Crystal Display |
| LORAN-C | Long range land-based radio navigation system operated by the U.S. Coast Guard |
| LSB | Least Significant Bit |
| MIF | Motorola Intermediate File |
| MMI | Man-Machine Interface |
| MNA | Mobile Navigation Assistant |
| MOE | Measure of Effectiveness |
| MPO | Metropolitan Planning Organization |
| NavTech | Navigation Technologies Corporation |
| NCP | Network Control Processor |
| NCP/IF | Network Control Processor Interface |
| NDT | Network Display Tool |
| NFM | Network Flow Model |
| NFS | Network File System |
| NHTSA | National Highway Traffic Safety Administration |
| NU | Northwestern University |
| NUTC | Northwestern University Transportation Center |
| NWCD | Northwest Central Dispatch |
| OAM | Operations Administration and Maintenance |
| OD | Origin-Destination |
| OOA | Object Oriented Analysis |
| OOD | Object Oriented Design |
| PI | Principal Investigator |
| PMP | Project Management Plan, Document #8200 |
| POI | Point of Interest |
| POP | Project Operations Plan |
| QA | Quality Assurance |
| QC | Quality Control |
| RAM | Random Access Memory |
| RD-LAP | Radio Data Link Access Procedure |
| RF | Radio Frequency |
| RFSRV | RF Server |
| RISC | Reduced Instruction Set Computer |

| | |
|--------------|---|
| RNC | Radio Network Controller |
| ROM | Read Only Memory |
| RPC | Remote Procedure Call |
| RPCGEN Tools | Remote Procedure Call Generation utility |
| RPMIF | Radio Packet Modem Interface |
| RTS | Request to Send |
| RXD | Received Data |
| SAE | Society of Automotive Engineers |
| SC | Steering Committee |
| SCADA | Surveillance Control and Data Acquisition |
| SE | Static Estimates |
| SIF | Standard Interchange File |
| SP | Static Profiles |
| SPU | Static Profile Update |
| SSI | Surface Systems Incorporated |
| SVRS | Stolen Vehicle Recovery System |
| TAC | Technical Advisory Committee |
| TBD | To Be Determined |
| TCP/IP | Transmission Control Protocol/Interface Protocol |
| TFHRC | Turner-Fairbank Highway Research Center |
| TIC | Traffic Information Center |
| TIGER | Topologically Integrated Geographic Encoding & Referencing files |
| TLI | (AT&T) Transport Layer Interface |
| TRB | Transportation Research Board |
| TravTek | Travel Technology |
| TRF | Traffic Related Functions |
| TSC | Traffic Systems Center |
| TT | Travel Time |
| TTL | Transistor-Transistor Logic |
| TTP | Travel Time Prediction |
| TXD | Transmitted Data |
| UDP | Universal Data Protocol |
| UIC | University of Illinois at Chicago |
| UIC-EECS | University of Illinois at Chicago - Electrical Engineering and Computer Science Department |
| UIC-UTC | University of Illinois at Chicago - Urban Transportation Center |

| | |
|------------|---|
| V & V | Verification & Validation |
| V & V Plan | Verification & Validation Plan, Document # 8300 |
| V & V Team | Verification & Validation Team |
| VNIS | Vehicle Navigation and Information Systems |
| YD | Yoked Driver |

THE *ADVANCE* PROJECT: FORMAL EVALUATION OF THE TARGETED DEPLOYMENT

EXECUTIVE SUMMARY

The Advanced Driver and Vehicle Advisory Navigation ConcEpt (*ADVANCE*) was an in-vehicle advanced traveler information system (ATIS) that operated in the northwest suburbs of Chicago, Illinois. It was designed to provide origin-destination shortest-time route guidance to a vehicle based on (a) an on-board static (fixed) data base of average network link travel times by time of day, combined as available and appropriate with (b) dynamic (real-time) information on traffic conditions provided by radio frequency (RF) communications to and from a traffic information center (TIC). Originally conceived in 1990 as a major project that would have installed 3,000 to 5,000 route guidance units in privately owned vehicles throughout the test area, *ADVANCE* was restructured in 1995 as a "targeted deployment," in which approximately 80 vehicles were to be equipped with the guidance units — Mobile Navigation Assistants (MNAs) — to be in full communication with the TIC while driving the *ADVANCE* test area road system.

Originally to have been evaluated formally as a fully deployed field operational test (FOT), *ADVANCE* by early 1995 required a modified evaluation scheme be developed in order to be realized as a targeted deployment. Such a plan was constructed by Booz•Allen & Hamilton, FOT support contractor to the FHWA Joint Program Office. The *ADVANCE Evaluation Management Plan* identified the roles and responsibilities of the test program participants, delineated the data management requirements, provided a resource management plan for the test vehicle fleet, and included detailed schedules for the completion of each evaluation task. This document, in concert with the *ADVANCE Evaluation Program Plan*, served as the foundation upon which test plans were developed, through extensive cooperation between staff and the evaluators, to direct data collection and management, analysis, and task management efforts for each of the individual tests.

Three of the four *ADVANCE* subsystems were formally evaluated; focused evaluations were also made of the performance of the system in its entirety. The evaluated subsystems were Traffic Related Functions (TRF), Mobile Navigation Assistant (examined in the context of its user friendliness/acceptance and its performance in route guidance), and Traffic Information Center. The interaction of these subsystems in concert with the RF communications subsystem (COM) was performance-tested by the dynamic route guidance and incident detection field evaluations.

The TRF algorithms used by *ADVANCE* were resident in the central computing facilities of the TIC. Their primary purpose was to screen, validate, and then process incoming real-time data from loop detectors (traffic volume and detector occupancy), MNA reports (travel times of probe vehicles on the various links), and any anecdotal information (such as emergency vehicle dispatch reports) to generate near-term estimates and predictions of travel time along any arterial link. These

reports and the resulting link travel time estimates were compared with values in the stored data base of historical average travel time for that day of week (measured for normal weekday vs. normal weekend vs. Friday/holiday) and time of day (five total time periods). If certain criteria were met, a travel time update was included in a message bundle for RF transmission to MNAs.

The purpose of the TRF subsystem field tests was to evaluate the performance of the components of the subsystem and the relative usefulness of probe-equipped vehicles (called “probes”), in-pavement loop detectors, and anecdotal incident reports to provide real-time traffic data. Specific questions to be answered were

- How well did the static profile, data screening, detector travel time conversion, data fusion, incident detection, and travel time prediction components of the TRF perform?
- How accurate were the initial travel time estimates generated by the Network Flow Model, which was used prior to system deployment to simulate traffic activity in the *ADVANCE* area?
- What was the relative value of the fixed detectors and the probe vehicles as sources of information for the incident detection and travel time prediction algorithms?
- What frequency of probe reports was needed to obtain reliable estimates of current link travel times and identification of (nonrecurrent) congestion?
- What was the accuracy of the probe travel time reports?

To answer these questions, paid drivers operating up to 15 *ADVANCE*-system-equipped vehicles four days per week (Monday-Thursday) drove predetermined routes for which their traversal times and other indicators of network performance (e.g., distances traveled at speeds less than 22.5 mph and time spent at less than 5 mph) for each link of the route were recorded at the TIC, along with arterial loop detector data. Performance indicators were analyzed to assess response, accuracy, and usefulness of the key TRF components, including fusion of data received from probes and detectors into a travel time prediction algorithm, construction of both the default static forecasts and the on-line dynamic forecasts, estimation of the number and frequency of probe traversals required for reliable travel time updates, and the relationship among vehicles’ travel times on a link as a function of turning movement and direction.

The MNA hardware configuration installed in *ADVANCE*-equipped vehicles included a display unit, located next to the driver, with a memory card (PCMCIA); a speaker for audio messages; a gyrocompass and transmission pickup for dead reckoning navigation, mounted inside the vehicle frame; antennas, attached to the rear exterior of the vehicle, for transmitting and receiving

RF messages and for receiving global positioning system (GPS) signals; and a navigation computer, sensor controller, RF modem, GPS receiver, and CD-ROM drive, all mounted in the trunk (or rear of a minivan's passenger compartment).

It had always been intended that drivers who reside in the study area be given the opportunity to experience the look, feel, and capabilities of the *ADVANCE* MNA for an extended period in their own cars and trucks. A focused test using study area residents was devised for the purpose of providing drivers familiar with the *ADVANCE* test area an opportunity to use the *ADVANCE* system in their normal driving behavior for a relatively extended period of time. It was expected that these drivers could contribute useful perspectives on the characteristics and performance of the *ADVANCE* system and help guide the design and development of future ATIS services.

The TIC, located at the *ADVANCE* project office, provided all centralized computing resources for the system, including processing, distribution, and archiving of system descriptive (static) and real-time-generated (dynamic) data. The purpose of the TIC evaluation conducted under the targeted deployment was to analyze the TIC hardware and software as a combined system, documenting reliability, examining system staffing and operation requirements and overall cost efficiency, and assessing system design alternatives from the perspective of system portability (to other sites and applications), maintenance needs, and ease and effectiveness of use by operators.

Two tests were more focused on all subsystems of *ADVANCE* operating as an integrated whole. In the dynamic route guidance (DRG)/yoked driver (YD) tests, a group of three equipped vehicles operated by paid drivers were driven, starting at approximately identical times, between a preselected origin and destination. Two members of each group followed routes planned and updated in real time through the communications link with the TIC, while the third followed a fixed (or static) route defined by the in-vehicle navigation unit by using only its embedded map and travel time data (i.e., no TIC communications). Two dynamically guided vehicles were used to ensure success of the test even if equipment in one vehicle malfunctioned. Eighteen equipped vehicles acting as probes departed ahead of this pair along alternative routes between each planned origin and destination to provide frequent travel time updates to the TIC. The objective of the test was to determine whether and how frequently the members of the pair that had full communication were given a route that was different from that provided by static guidance only *and* that saved time or had a *potential* time-saving benefit relative to the static route. In the incident detection (ID) evaluation, prestaged and roving field vehicles from a deployed fleet of up to 12 were dispatched in real time to the scene of either a reported incident or a known, actual (or simulated) construction delay. If an actual delay condition was found, these probe-equipped vehicles traversed the affected area repeatedly to measure travel times. Later, the vehicles returned to the incident sites to record travel times under normal conditions. The reliability of the algorithm that identified (a) nonrecurring incidents and construction and (b) incident delays by means of loop detector data and data fusion was evaluated with data collected from these traversals.

RESULTS

Reports from 50,620 probe traversals were collected during the TRF field tests and examined. Of these, 88 had unacceptably high speed, 95 had unacceptably high congested distance (longer than the link itself), and 115 had an unacceptable match between congested distance and congested time (i.e., time on the link spent at speeds at or less than 10 m/sec — about 22.5 mph). Of those 115 reports, 11 were also in the set of unacceptable speed reports. Thus, 287 reports were found to be suspect, or about 0.6 percent of the total, and many of these were traceable to a single faulty MNA. Further, when 776 of these probe-reported values were compared to manually recorded values observed at the same time, 87.6% of values were within plus or minus five seconds and 94% within plus or minus ten seconds, with substantial clustering within two seconds or less. The overall conclusion is that MNA data proved a reliable indicator of traffic conditions in *ADVANCE* and thus could provide a valuable resource for traffic monitoring and analysis in future ATIS deployments.

After two or three updates based on probe traversal data, the static (average) profiles of travel times by time of day in the *ADVANCE* network became very accurate. Updated algorithms performed well against occasionally idiosyncratic probe reports, and data were screened appropriately, eliminating many reports from malfunctioning MNAs. Profiles based on probe data only were found to be more accurate than those based on both probe and detector data.

In most instances, three probe reports per five-minute interval were adequate to provide reasonable travel time estimates and predictions on the arterial system. Increasing this probe rate produced very little change in the output forecasts, a result consistent with an evaluation of probe frequencies, which found that the variance of arterial travel time estimates never approaches zero regardless of the number of probes, and that the quality of estimate essentially stops improving above relatively few traversals per five-minute interval. These factors argue strongly that very high levels of probe deployment are probably *not* necessary for an effective probe-based ATIS. However, all prediction algorithms would be enhanced by the inclusion of traffic signal timing data on the network roadways.

The user features of an in-route guidance system, such as those of the MNA units deployed for *ADVANCE*, must be able to accommodate a reasonably broad range of technological sophistication and network knowledge among the population likely to pay for and regularly use such a system and its associated services. Specifically, the capability should exist to “train” the system to learn the user’s preferred routes, then provide timely and relevant information about available time savings on alternative routes (especially those which may be “counter-intuitive” to a user familiar with the area road network). In general, users who regularly drive in a road network and know its normal traffic and congestion patterns tolerate recurrent time-of-day delays in the network on the links with which they are familiar and comfortable; thus, only a route guidance system capable of providing reliable real-time data about *non*-recurrent congestion is likely to find a market base beyond very specialized, very limited applications.

For successful identification of instances of nonrecurrent congestion, results of testing the *ADVANCE* incident detection algorithms were mixed. Although the composite results of the evaluation called into question the ability to generally apply previously estimated freeway/expressway incident detection algorithms without complete recalibration of parameters, they revealed substantial potential for further development of reliable arterial incident detection algorithms based on volume and occupancy data from fixed detectors and/or link traversal data from probe vehicles. A modified algorithm based on probe and detector data in the arterial system that used data from three probe traversals per fifteen minutes detected nine of nine incidents without false alarms.

In the DRG/YD tests, it was established that route diversions and travel time savings are sometimes associated with the use of real-time data for route planning, but in an arterial network like that of *ADVANCE*, in which DRG is subject to key functionality limitations, large time savings may not be a typical outcome. Where substantial time savings occurred during the test, the cause appeared to be availability of less congested (but, paradoxically, *longer or orthogonal*) links proximate to highly congested routes. *Such alternative routes, in the absence of DRG, are likely in most instances to appear illogical to drivers on the congested route and thus unlikely to be found and followed without a route planner using real-time information for the entire network.*

Evaluation of the TIC confirmed that the TIC architecture as implemented provided an acceptable level of performance for the demands made on it by the targeted deployment with respect to both hardware and software as individual components and as a complete system. Moreover, it provided an acceptable cost efficiency for the scope of its mission, enabled successful system operation, ensured reasonable operator workload with its procedural practices, and provided an acceptable level of usability and functionality of user interface (although operator comments about unused features and suggestions for additions and enhancements indicated that many features of this interface might be improved). However, it was found that the architecture as implemented for the targeted deployment operational tests is not directly or immediately expandable to cover additional services within the current test area due to inherent system limitations deriving from reduced project scope. Nor is it directly transferable to other geographic areas because it was a unique technical solution that, as an entire system, has limited application and capability to meet local requirements in other areas. The prospects for transferability of its major system components are very good.

CONCLUSIONS

From a practical standpoint, a number of lessons were learned about operating an FOT, whether full-scale or otherwise; these lessons are discussed in depth in a series of "Insights and Achievements" white papers. While it is true that the scope of testing of dynamic route guidance capabilities, the effect of the system on "familiar" drivers, and the ability to assess long-term operational and maintenance aspects of the system were far more limited than the original *ADVANCE* concept stipulated, there is clearly a subset of results of the *ADVANCE* evaluation that

would not change regardless of its scale of deployment. Probably chief among these is that, although real-time guidance on arterial networks can be provided (at significant public expense) in the absence of equipped vehicle probes, its quality and usefulness will be much diminished relative to what even a very limited deployment of probes could achieve. The *ADVANCE* targeted deployment tests argue that probe data constitute such an essential component of reliable arterial dynamic travel time information that traffic management agencies in large urban areas should actively undertake to recruit a small population of commercial and private vehicles to serve as automatic vehicle locator (AVL) probes for operation on arterials and expressways. (Such AVL deployment has already occurred in the San Francisco Bay area and is being contemplated elsewhere.) In this way, without the need for specifically identifying individual vehicles, a vital, generally unprecedented, and perhaps ultimately indispensable stream of travel time information for the *total* network would begin to flow into regional traffic management centers.

The decision to adopt a targeted deployment approach for *ADVANCE* was a logical step in developing and advancing ITS technology. The dynamic route guidance concept which was central to *ADVANCE* was tested, the project infrastructure developed was enhanced to support a broader range of ITS deployments, and multistate corridor activities were supported and given a more central focus. The public and private participants in the project gained highly useful information from systems development and evaluation testing that has helped positively and productively to guide further ITS concept and product deployment pursuits.

THE ADVANCE TARGETED DEPLOYMENT: THE EVALUATION MANAGER'S OVERVIEW REPORT

1 GENESIS OF THE TARGETED DEPLOYMENT AND ITS FORMAL EVALUATION

The Advanced Driver and Vehicle Advisory Navigation ConcEpt (*ADVANCE*) was an in-vehicle advanced traveler information system (ATIS) that operated in the northwest suburbs of Chicago, Illinois. It was designed to provide origin-destination shortest time route guidance to a vehicle on the basis of (a) an on-board static (fixed) data base of average network link travel times by time of day, combined, as available and appropriate, with (b) dynamic (real-time) information on traffic conditions provided by radio frequency (RF) communications to and from a traffic information center (TIC). A schematic diagram of the information flow in the *ADVANCE* system is shown in Figure 1.

ADVANCE, which pioneered many of the public/private organizational arrangements and technical features now considered commonplace for Intelligent Transportation System (ITS) deployments across the United States, was unique in its use of "probe" vehicles to dynamically generate travel time information for arterial and local streets.

During the summer and fall of 1995, the *ADVANCE* system underwent a series of formal evaluation tests of the performance of its subsystems, as well as of the most important aspects of the system overall. The impetus for these tests, as discussed below, was the decision to deploy the *ADVANCE* concept as a limited but very focused demonstration of the system's capabilities and thereby conserve considerable public resources.

Originally conceived in 1990 as a major project that would have installed 3,000 to 5,000 route guidance units in privately owned vehicles throughout the test area, *ADVANCE* was restructured in 1995 as a "targeted deployment." Late in 1994, it was concluded that the technological capabilities and user features of the *ADVANCE* system, though state-of-the-art, might be difficult to combine in a package that consumers could reasonably afford. In addition, actual sales for other products with similar but nondynamic and less comprehensive features were smaller than expected. The lack of a logical, assured product development and rollout path prompted the decision to deploy *ADVANCE* in a manner that could test its effectiveness and performance, without committing millions of public and private dollars to the installation and long-term operation of 3,000 navigation units in private vehicles. Thus was born the idea of a targeted deployment, in which approximately 80 vehicles would be equipped with the navigation units — Mobile Navigation Assistants (MNAs) — to be in full communication with the TIC while driving the *ADVANCE* test area road system. The parties developing *ADVANCE* (see the *ADVANCE* participants, page V1-xi)

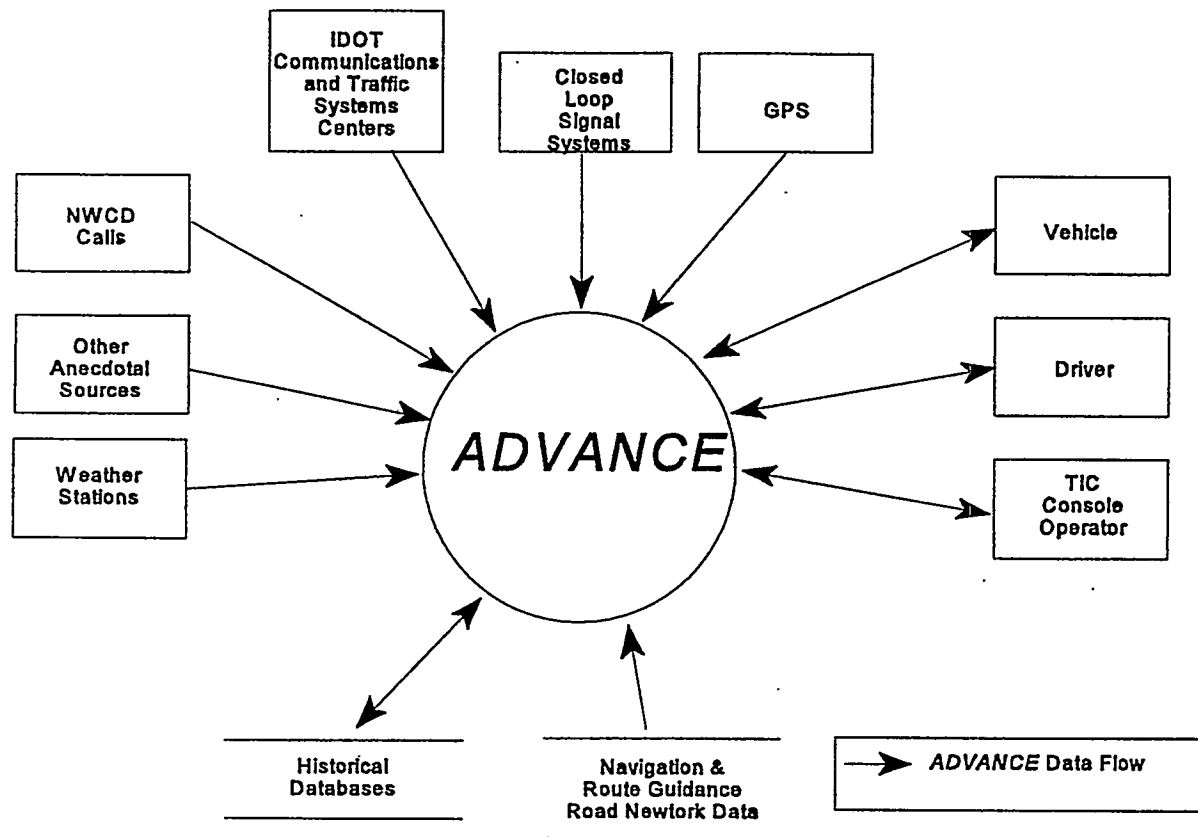

FIGURE 1 Dynamic Information Flow in *ADVANCE*

also agreed that the *ADVANCE* dynamic route guidance testing had produced significant technological accomplishments having future potential governmental and commercial application, and that documentation of these technologies and accomplishments needed to be made available to the public and to commercial enterprises more quickly than would have been possible under full deployment.

Deployment of new ITS technology demands verification that the purposes of the deployment are achieved and that *results* of development and deployment are commensurate with *resources expended*. The original planning for the *ADVANCE* deployment called for compilation of a large evaluation data base throughout the expected four-year project lifetime. This data base would have provided the basis for broadly informative and reliable tests of the various features of the project's systems and subsystems with respect to their capability to perform their stipulated missions. It became apparent early in 1995 that the resizing of the *ADVANCE* project to a smaller, targeted deployment, would necessitate development of an evaluation program and management plan different from what had earlier been drafted for full deployment. Moreover, the contract for evaluation manager had not yet been signed with Argonne National Laboratory (Argonne), the organization selected to fulfill that responsibility. Because the needed reformulation of the evaluation testing and management scheme could not be postponed until such a signed contract was in place,

the Federal Highway Administration (FHWA) requested Booz•Allen & Hamilton, already under an FHWA contract, to assume the role of interim evaluation manager. In this role, Booz•Allen was tasked with directing the expeditious completion of evaluation and test planning requirements.

In developing plans for assembling an evaluation data base, objectives changed primarily in scope: although sample sizes and the number of data points were significantly diminished, it was still possible to collect adequate data to inform others about expected performance of and user response to similar system deployments. This philosophy motivated the developers of the *ADVANCE* evaluation plan, in concert with the evaluators, to devote considerable attention to redefining the objectives and resources necessary to conduct useful tests, then to deriving a feasible schedule under known time constraints for conducting all needed activities in the field and at the *ADVANCE* TIC. As applicable, the evaluation test plans that were ultimately prepared identified

- Data to be collected and the procedure for their collection,
- Hypotheses about system performance to be tested using these data,
- Chronological window(s) (calendar dates) during which data would be collected, and
- Resources required to perform the tests.

The *ADVANCE Evaluation Management Plan* (Document #8450) identified the roles and responsibilities of the test program participants, delineated the data management requirements, provided a resource management plan for the test vehicle fleet, and included detailed schedules for the completion of each evaluation task. This document, in combination with the *ADVANCE Evaluation Program Plan* (Document #8400), and extensive cooperation between staff and each of the evaluators, served as the foundation upon which test plans were developed to direct data collection and management, analysis, and task management efforts for each of the individual tests.

Early in May 1995, the evaluation management contract was signed with Argonne. By prior agreement, the Booz•Allen team remained in place to fulfill its responsibilities and conduct an orderly transition to Argonne's management; this transition was accomplished by mid-June. Argonne, in its position as evaluation manager, subsequently endeavored to ensure that all tasks were conducted in complete consistency with the scope and schedule of the plans developed by Booz•Allen & Hamilton and the respective evaluators. This endeavor was successfully completed.

2 SCOPE AND STRUCTURE OF THE EVALUATION

As described below, testing was conducted in the field and at the TIC in support of performance evaluation for each of three major *ADVANCE* subsystem features. These features are described in this section.

2.1 TRF SUBSYSTEM

The Traffic-Related Functions (TRF) algorithms used by *ADVANCE* were resident in the central computing facilities of the TIC. Their primary purpose was to screen, validate, and then process incoming real-time data from loop detectors (traffic volume and occupancy), MNA reports (link travel times of probe-equipped vehicles called "probes"), and any anecdotal information (such as emergency vehicle dispatch reports) to generate near-term estimates and predictions of travel time along any link. These reports and their resulting link travel time estimates were compared with values in the stored data base of historical average travel time for that day of the week (measured for normal weekday vs. normal weekend vs. Friday/holiday) and time of day (five total time periods). If certain criteria were met, a travel time update would be included in a message bundle for RF transmission to MNAs.

The base travel time values against which real-time data were compared had been generated by either a network equilibrium flow model or a static profile update incorporating real traversal time measurements. The navigation network used by *ADVANCE* for real-time travel updates contained 7,253 directional segments with 1,580 intersections, of which 699 were signalized. To code this network for appropriate representation as a data base, 274 boundary segments were defined around the test area, while every approach segment to an (eligible) turning movement was expanded to add a turning movement segment (this latter modification alone increased the number of coded links by a factor of 2.5). Turning movements and arterial signals were abstracted as delay functions.

In every 5-minute interval, TRF screened incoming data, then executed the following tasks:

1. Determined the presence of a lane-blocking or flow-retarding condition on any link by comparing probe traversal time and loop detector volume and occupancy reports with the static profile or by directly incorporating an anecdotal incident report; if time difference criteria were met, an incident report/flag for that link was generated.
2. Estimated current travel time on the basis of *fusion* of detector (where available) and probe data, or *individually* if either source were missing or had failed screening criteria. When both sets of data were available and screened as acceptable, the travel time estimator fused them in an equation

incorporating adjustment factors weighted according to (a) the standard deviations of the average travel time estimates from each source and (b) how influential the detector travel time should be in the combined estimate.

3. Computed travel times on the link for the next four 5-minute intervals (i.e., up to 20 minutes into the future). Probe and fusion data were used in this computation except where an incident had been confirmed, in which case the expected incident duration was applied. Data for the link were standardized by mean and standard deviation of the combined probe and detector values, and travel times were predicted in a function that gradually “decayed” back to the static average time after the last 5-minute interval. The outgoing message contained all four 5-minute computed values.

The *purpose* of the TRF subsystem field tests was to evaluate the performance of the components of the subsystem and the relative usefulness of probe-equipped vehicles, in-pavement loop detectors, and anecdotal incident reports in providing real-time traffic data. Specific questions to be answered were

- How well did the static profile, data screening, detector travel time conversion, data fusion, incident detection, and travel time prediction components of the TRF perform?
- How accurate were the initial travel time estimates generated by the Network Flow Model, used prior to system deployment to simulate traffic activity in the *ADVANCE* area?
- What is the relative value of the fixed detectors and the probe vehicles as sources of information for the incident detection and travel time prediction algorithms?
- What frequency of probe reports is needed to obtain reliable estimates of current link travel times and identification of (nonrecurrent) congestion?
- What is the accuracy of the probe travel time reports?

The *procedures* developed for the seven interrelated TRF field tests, managed by the University of Illinois at Chicago Urban Transportation Center (UIC-UTC) faculty, used paid drivers operating up to 15 *ADVANCE* system-equipped vehicles four days per week (Monday-Thursday). The vehicles were driven along predetermined routes for which traversal times and other indicators of network performance for each link (e.g., distances traveled at speeds less than 22.5 mph and time spent at less than 5 mph) were recorded at the TIC, along with arterial loop detector data. Figure 2 shows the primary route used. Performance indicators were analyzed to assess (1) response,

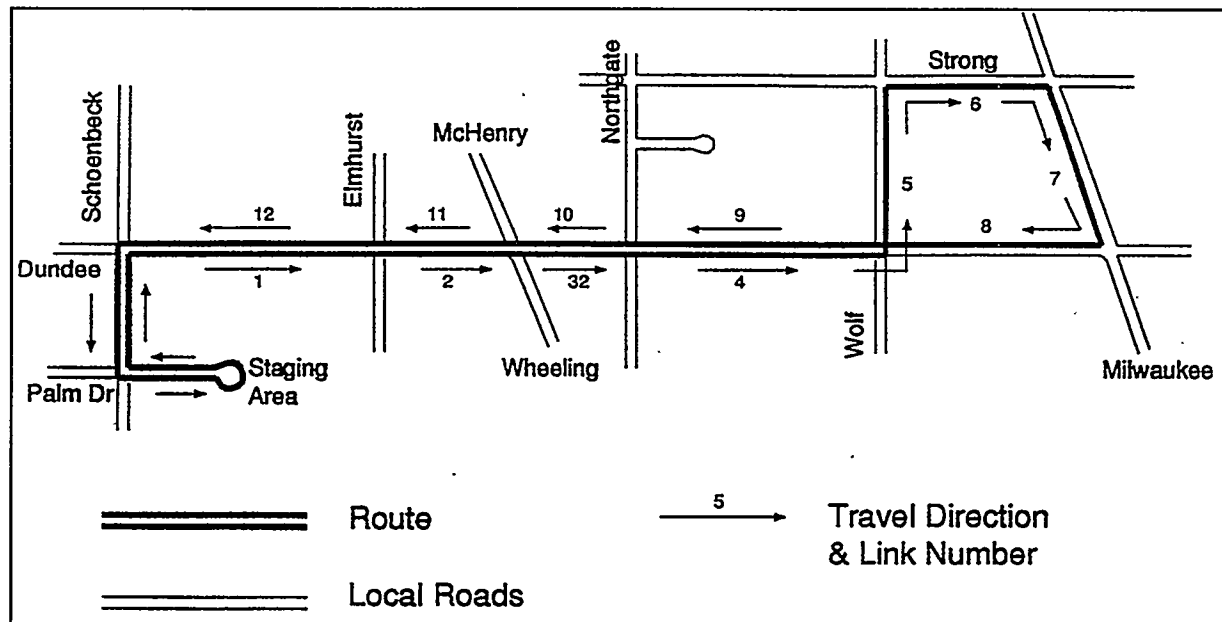

FIGURE 2 Primary Route Used in TRF Field Tests

accuracy, and usefulness of the key TRF components, including fusion of data received from probes and detectors into a travel time prediction algorithm; (2) construction of both the default static forecasts and the on-line dynamic forecasts; (3) estimation of the number and frequency of probe traversals required for reliable travel time updates; and (4) the relationship among vehicles' travel times on a link as a function of turning movement and direction.

A more detailed description of the field testing activities and protocols of the TRF evaluation is provided in Section 4 of this overview. The results of the analysis of data arising from these tests are presented in the evaluation reports accompanying this evaluation manager's report as

- Appendix A: Base Data and Static Profile Evaluation Report (#8460-01.01)
- Appendix B: Data Screening Evaluation Report (#8460-02.02)
- Appendix C: Quality of Probe Reports Evaluation Report (8460-03.01)
- Appendix D: Travel Time Prediction and Performance of Probe and Detector Data Evaluation Report (#8460-04.01)
- Appendix E: Detector Travel Time Conversion and Fusion of Probe and Detector Data Evaluation Report (#8460-05.01)
- Appendix F: Frequency of Probe Reports Evaluation Report (#8460-06.01)
- Appendix G: Relationships among Travel Times Evaluation Report (#8460-07.02)

One of the principal purposes of TRF and TIC functions was to generate, in real time, link travel time updates that could be broadcast to MNAs and enable them to determine a near-optimal (least-time) point-to-point route at a given time interval. A test was constructed to determine whether, and to what extent, dynamic route guidance (DRG), as implemented in the *ADVANCE* system, could significantly improve travel times for drivers. The test had two central facets: yoked-driver (YD) timing and incident detection (ID) timeliness.

In the dynamic route guidance/yoked driver (DRG/YD) tests, a group of three equipped vehicles operated by paid drivers were driven, starting at approximately identical times, between a preselected origin and destination. Two members of each group followed routes planned and updated in real time through the communications link with the TIC, while the other followed a fixed (or static) route defined by the in-vehicle navigation unit, using only its embedded map and travel time data (i.e., no TIC communications). Two dynamically guided vehicles were used to ensure success of the test even if equipment in one vehicle malfunctioned. Eighteen equipped vehicles acting as probes departed ahead of this pair along alternative routes between each planned origin and destination to provide frequent travel time updates to the TIC. An example of one of these origin-destination networks and possible routings is shown in Figure 3. The objective of the test was to

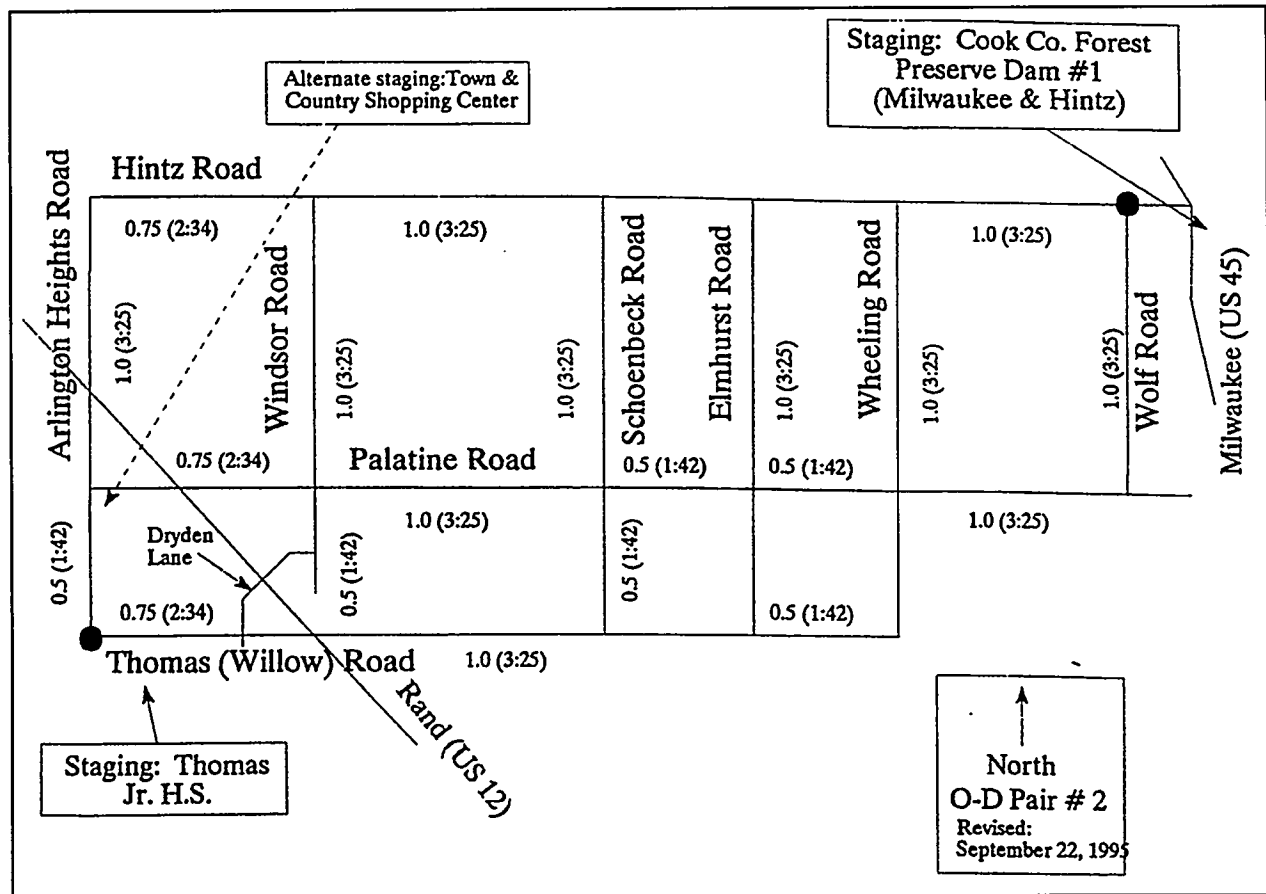

FIGURE 3 Example Origin-Destination Pair for Yoked Driver Test

determine whether and how frequently the members of the pair that had full communication were given a route that was different from that provided by static guidance only *and* that saved time or had a *potential* time-saving benefit relative to the static route. These tests, managed by faculty of Northwestern University Transportation Center (NUTC), were conducted weekdays and early evenings by using drivers hired by Northwestern University throughout the month of September 1995.

In the ID evaluation, prestaged and roving field vehicles from a deployed fleet of up to 12 were dispatched in real time to the scene of either a reported incident or a known, actual (or simulated) construction delay. If an actual delay condition was found, these probes traversed the affected area repeatedly to measure travel times. Later, the vehicles returned to the incident sites to record travel times under normal conditions. The reliability of the algorithm that identifies (a) non-recurring incidents and construction and (b) incident delays by means of loop detector data and data fusion was evaluated with data collected from these traversals. Tests were conducted by NUTC during weekday periods of recurrent, nonrecurrent, and incident-related congestion (both naturally occurring incidents and staged incidents were used) during summer and autumn 1995.

A more detailed description of the field testing activities and protocols of the DRG and ID evaluations is provided in Section 4 of this overview. The results of the analysis of data arising from (1) the ID and (2) the DRG test are presented in the evaluation reports appended to this document as

Appendix H: Evaluation of Arterial Probe Vehicle, Fixed Detector and Expressway Fixed Detector Incident Detection Algorithm Evaluation Report (#8461.01)

Appendix J: Field Test of the Effectiveness of *ADVANCE* Dynamic Route Guidance on a Suburban Arterial Street Network Evaluation Report (#8463.01)

2.2 MNA SUBSYSTEM

Look, Feel, and Capabilities. The MNA hardware configuration installed in *ADVANCE*-equipped vehicles included a display unit, located next to the driver, with a (PCMCIA) memory card; a speaker for audio messages; a gyrocompass and transmission pickup for dead-reckoning navigation, mounted inside the vehicle frame; antennas, attached to the rear exterior of the vehicle, for transmitting and receiving RF messages and for receiving global positioning system (GPS) signals; and a navigation computer, sensor controller, RF modem, GPS receiver, and CD-ROM drive, all mounted in the trunk (or rear of a minivan's passenger compartment).

The navigation computer was activated when the vehicle was started, becoming functional after about a one-minute warmup, and shut down after safely closing out all its active functions when the ignition was turned off. It was designed to function in ambient temperatures ranging from -40°C to $+85^{\circ}\text{C}$ and was capable of operating effectively in a rough-service environment with respect to impact shock, vibration, and voltage spikes.

The display head to the driver's right contained a 5.7-inch diagonal screen featuring an infrared-based touch panel with backlit color LCD. A memory card slot housed a 2MB PCMCIA card (formatted to 1.44 MB) that stored link traversal data and other messages transmitted to and from the TIC. The purpose of this memory card was to assist in retrieval and storage of data to be used in the evaluation. Buttons to the right of the screen or touch prompts on the screen itself could be pressed to bring up one of the following principal displays:

1. A selection menu for route planning, network/location map, or user interface adjustment.
2. *Route planning* mode: an option to select destination by address or intersection; up to seven addresses can be stored for future use and accessed from a screen linked to display 3 below.
3. Following display 2, an alphanumeric touch keypad to enter destination street names, address numbers, and/or towns in the *ADVANCE* data base (a choice of streets or towns is offered by pressing "ENTER" on the touch pad).
4. Following display 3 and the "best" route computation by the system (which uses the static network data on the CD-ROM and/or real-time information transmitted from the TIC), the LCD displays a straight-ahead, left-, or right-turn arrow indicator of the distance to the next required turn (onto the street listed at the top), supplemented by an auditory cue as the turn approaches. The street on which the vehicle is *currently* traveling is printed at the bottom of the display, which refreshes with a new direction and street name as each turn maneuver is accomplished, until the destination is reached.
5. *Map* mode: a "zoomable" north-up portion of the map network approximately centered on the vehicle's current location; this location is indicated by (a) the name of the street currently occupied (at the bottom) and the next street to be intersected (at the top), (b) a solid circular icon based on the GPS locator, surrounded by an orange ring if the vehicle position is receiving GPS range correction from the TIC (if the color of the solid circle changed from green to yellow, the GPS signal was being received from only three satellites; upon further loss of the signal, no circle whatsoever is shown), and (c) a red triangle

indicating the vehicle's position according to the MNA's map-matching and dead-reckoning computer function.

6. "ADJ" mode (accessed by a button on the display head): a prompt to change display brightness or volume of the auditory cue.

A few additional screens in the "MORE" mode, also accessed by button, enable users to identify or re-specify the trip starting point, enter their user identification and password, and modify other system control parameters. These screens were rarely accessed by the paid or volunteer drivers who operated project cars during the targeted deployment.

The display could not be toggled between route planning and map modes. However, a route plan could be canceled in navigation mode, and a stored destination could then be selected for route recomputation or the map could be accessed.

In *ADVANCE*, the planned route was not highlighted in map mode. The user could review an entire route in navigation mode by repeatedly pressing the "next maneuver" panel on the turn arrow display until the destination screen appeared. It was also possible to display the selected route length in miles (from origin to destination only, not from some intermediate point). If a driver deviated from a planned route in navigation mode, an "off-route" indicator appeared, accompanied by a warning chime and a query as to whether a route to the destination should be replanned from the current location. Touching the "YES" display button would reactivate the route planner, and the turn-arrow display would shortly reappear with the first maneuver in the new route sequence.

As applicable, real-time information passed from the TIC would indicate that a route different from that originally plotted could save at least two minutes. At this point, the display would chime and a window would pop up to provide the user the predicted total time savings and ask whether the new route should be taken; if "YES" was touched, the turn-arrow display would return with the first maneuver of the new route from the vehicle's current location.

Volunteer Driver Experience. It had always been intended that drivers resident in the study area be given the opportunity to experience the look, feel, and capabilities of the *ADVANCE* MNA for an extended period in their own cars and trucks. The targeted deployment reduced the opportunity for such an immersion experience to two weeks in a project vehicle. Nevertheless, evaluators believed that such a brief volunteer driver acquaintance with a prototype system could nevertheless generate much useful information for *future* development of in-vehicle navigation products and services. Thus, a focused test using study area residents was devised that had the purpose of providing drivers familiar with the *ADVANCE* test area an opportunity to use the *ADVANCE* system in their normal driving behavior for a relatively extended period of time. It was expected that these drivers could contribute useful perspectives on the characteristics and performance of the *ADVANCE* system and could help guide the design and development of future ATIS services.

This series of tests began in late July, with the most intense activity occurring from October through early December 1995. The tests involved families living in the test area that had volunteered to drive *ADVANCE*-equipped, project-supplied vehicles for a two-week period. These volunteer drivers completed both baseline and post-test surveys and maintained logs that noted malfunctions, problems, reroutes, and the drivers' responses. Subsequently, 30 percent of these drivers participated in focus groups that examined their experiences and reactions. This test and the follow-up focus groups were managed by Northwestern University. The results of the analysis of data arising from this test are presented in the evaluation report appended to this document as

Appendix I: Familiar Driver Perspectives on *ADVANCE* and Future Dynamic Route Guidance Systems Evaluation Report (#8462.01)

In addition, a formal study of the inherent safety of the MNA display and its potential for driver distraction relative to other means of route guidance was conducted by the University of Iowa under separate contract. Results of that analysis will be presented in a report to be separately submitted to the Volpe National Transportation Systems Center and the FHWA Joint Program Office.

2.3 TIC SUBSYSTEM

The TIC, located at the *ADVANCE* project office, provided all centralized computing resources for the system, including processing, distribution, and archiving of system descriptive (static) and real-time-generated (dynamic) data. The central computer was a Sun SPARC 670 multiple-processor server having 128-MB dynamic random access memory available, along with a 13.6 gigabyte disk drive, a 5.0-GB capacity off-line tape drive (for storage and archiving), and a CD-ROM drive. The rack modem for receipt of external data supported 16 slots (for the two 16-port synchronous interface cards) at 14,400 baud rates. The main operator consoles were Sun SPARC X-Windows terminals linked to the server by 10 BaseT Ethernet cabling.

All TIC software modules (including TRF processes, described below) interacted with the TIC data base and each other, using interprocess communication protocols without interrupts. Static data included the digital map data base of the road network, including link-by-link average travel times by time of day based on either the results of a network flow model or an updated (static profile) value derived from actual measurement. Dynamic data included expressway and arterial loop detector reports, vehicle probe travel time reports, incident reports from a regional 911 system, and any relevant weather data. Inbound message processes validated and managed reception and storage of reports from the Traffic Systems Center (expressways), Dundee Road loop detectors, and probe vehicles (MNAs), while the outbound processes involved a message scheduler that grouped updated dynamic data into packets for RF transmission to MNA-equipped vehicles. During the targeted deployment, these updates were transmitted at 4-second intervals, every fourth message being a differential GPS range correction. Outbound link update messages contained the 10-digit link

identifier and travel time predictions for the current and ensuing 5-, 10-, and 15-minute intervals. These messages (for any given link) were transmitted as frequently as the volume of updates permitted.

In general, during the targeted deployment, data were very infrequently lost (i.e., failed to be added to a scheduler bundle). The critical threshold was approximately 13 updates per message; if this total was exceeded in any update, messages were transmitted in a subsequent bundle, but if all bundles were at or above the threshold for five minutes, any unsent message(s) was erased. At any given time the TIC was simultaneously (a) receiving inbound information by RF on an almost continuous basis; (b) sorting and directing this information to log files, display windows, and/or TRF processing algorithms; and (c) preparing and scheduling for RF transmission outbound messages to project vehicles (about 15 times per minute). Up to 10 windows could simultaneously be displayed on the TIC console for operator viewing, use, and monitoring of system functions.

The purpose of the TIC evaluation conducted under the targeted deployment was to analyze the TIC hardware and software as a combined system, documenting reliability, examining system staffing, operation requirements, and overall cost efficiency, and assessing system design alternatives from the perspective of system transferability (to other sites and applications), maintenance needs, and ease and effectiveness of use by operators.

This evaluation began with a pilot test in September 1995, with the most intense activity occurring from October through early January 1996. Following a thorough review of system specifications, evaluators assembled data by means of the TIC real-time log, in which recorded known times and dates when malfunctions occurred were recorded. When a malfunction was identified, this log provided information on cause and remedial actions taken. Other automated logs created by the system describing separate processes were also examined, as were logs of such nonautomated functions as the entry of police dispatch and anecdotal traffic incident reports. Time stamps on each of these logs indicated how long it took for the TIC to formulate and transmit dynamic traffic messages, with and without operator intervention. Tests were performed to ascertain the maximum amount of data that could be entered into the system before incoming data were lost due to system overload. These tests determined if the TIC was adequate for the amount of data that required processing during the targeted deployment. In addition, measurements were made of the duration of the back-up cycle necessary to avoid compromising TIC functions.

Data were collected on the operational efficiency of the TIC in the absence of human intervention. This information was obtained by computing the amount of data entered *manually* as a percentage of *total* data used by the TIC (most data enter and are processed by the system automatically). To evaluate whether elements of the TIC architecture could be simplified without compromising system performance, there was an ongoing consultation process with a knowledgeable peer review team. These peers, familiar with the transportation situation in the Chicago area, also participated in a review process to consider the additional services that could be incorporated into the TIC operation by using functionality review documentation. TIC architecture capital and

operating costs were assessed on the basis of all the available expenditure information provided by project partners and the *ADVANCE* project office.

The effects of policies, procedures, and staffing levels on efficient TIC operation were investigated by means of a structured questionnaire, observations, and informal discussion sessions with TIC operators and supervisors. The questionnaire was administered very late in 1995 to provide for maximum exposure of the operators to procedures in place at the TIC. In addition, a manual TIC-operator observation log was available at all times during the TIC architecture evaluation period to enable operators or the supervisor to note any issues relevant to operational practices. TIC operators and their supervisor were briefed at the outset of the evaluation period on the purpose and scope of the operational practices evaluation, informed of the purpose of the TIC-operator observation log and evaluator observations, and notified that they would be interviewed near the end of the evaluation period.

A structured questionnaire, evaluator observation sessions, and related log sheets were used to assess various aspects of the usability and functionality of the TIC user interface. The usability evaluation considered such elements of the interface as workstation layout, screen format, task and menu structure, demands made on the operator by the system for data input and process monitoring, and degree of feedback provided by the system to the operator. The functionality evaluation involved an assessment of interface features to identify additional features that might be required or desirable, as well as any features already provided that were superfluous.

The TIC Architecture and User Interface evaluation tests were conducted by DeLeuw, Cather & Company, with the assistance of Castle Rock Consultants. The results of the analysis of data arising from this test are presented in the evaluation report appended as

Appendix K: TIC Architecture and User Interface Evaluation Report (#8464.03)

2.4 COM SUBSYSTEM

Because a proven product was employed, no formal testing of the fourth subsystem, the RF communications (COM) component, was conducted as part of the targeted deployment. The successful functioning of the other three components was always dependent on the efficient functioning of COM, so to the degree that these other subsystems performed according to specification and fulfilled their desired objectives during the targeted deployment, COM was also successful. Moreover, no weaknesses or malfunctions of any of the other subsystems during testing were ever attributed to a failure of COM as an independent operation (i.e., when its response performance, such as for providing differential GPS corrections, was unaffected by the response time delays for other MNA functions).

It should also be noted that a high-speed communications system was developed for application in the full *ADVANCE* deployment. Although targeted deployment did not require use of this system, details about its initial concepts are available in Section 4 of the *System Definition Document, #8020.ADV*, in the Insights & Achievements White Paper B of *Document #8465* appended to this report, and in a series of technical reports on RF COM design and acceptance testing that can be downloaded from the *ADVANCE* Internet page at the URL <http://ais.its-program.anl.gov/>.

3 EARLY RESOURCE, PHYSICAL, AND INSTITUTIONAL CHALLENGES TO EVALUATION

As scoped, some of the evaluation tests scheduled to begin in August 1995 required up to 22 vehicles to be in the field at any one time. Conduct of routine maintenance combined with the occasional necessity of unplanned repairs dictated that the pool of equipped vehicles at the project office exceed this requirement by at least two vehicles. At the outset of testing in June, 15 to 18 equipped vehicles were fully under the project's control. The evaluation manager secured eight additional vehicles in mid-July through a rental agreement, such that the project "motor pool" had sufficient change-out flexibility by the commencement of the most resource-intensive tests, to enable all tests to be conducted with full vehicle complement. Also in late August, six additional vehicles were obtained from the Ford Motor Co. for use in the field tests. Thus, *ADVANCE* reached the full population of 30 fully deployable vehicles. These 30 vehicles remained in service from late summer to the completion of field testing on December 14. From this experience it was learned that a daily procedure was required to assure that availability of test vehicles match the resource requirements of the test(s) to be run on that day.

In 1995 the Chicago region experienced one of its hottest summers on record. Although the discomfort of drivers could be alleviated by using air-conditioned vehicles, some of the electronic components of the in-vehicle systems, specifically the CD-ROM drives, were mounted in locations (such as the trunk) that were not cooled from the passenger compartment. As a result, these drives experienced functional difficulties, attributed largely to the high-temperature environment in the trunks of some of the vehicles. These components were frequently exposed to temperatures in excess of 65 degrees Celsius, although the drives themselves were not certified for functioning above 60 degrees. Late in June, all test vehicles received replacement drives that operated successfully up to at least 65 degrees Celsius, and systematic drive failure and degradation of MNA performance ceased thereafter when reasonable precautions were taken to keep the trunks cool (e.g., parking cars in shaded areas and opening trunk lids during breaks).

The project required drivers participating in the *ADVANCE* tests to meet certain insurance requirements. During the driver recruitment phase, it was the recommendation that paid drivers provide their own insurance. This option would have proved difficult for a number of potential drivers who did not own automobiles. Ultimately, *ADVANCE* assumed the insurance coverage cost for the paid drivers, and this ceased to be a problem before even driving began. However, *ADVANCE* legal counsel suggested that paid drivers sign a waiver limiting the liability of the *ADVANCE* project for any accident that happened when the drivers were on duty in the field. The language of this waiver was legalistic and not well understood by most drivers. Early in the test process, several of the drivers became quite concerned about the liability risks they faced in their daily work. This became a topic of discussion among the group of drivers and ultimately resulted in several of the drivers quitting because the perceived risk was unacceptable. To preclude loss of more drivers, the Northwestern team arranged for the university's Risk Management Office to conduct a detailed

review of insurance coverage provided to drivers employed by the university. The review made clear that the drivers were protected by three levels of insurance: the university's own insurance (as Northwestern was the employer of record); insurance carried by the Illinois Universities Transportation Research Consortium; and the policy carried by *ADVANCE*. The risk managers determined that drivers were amply covered — a point the waiver form failed to make clear, thus giving rise to the perception of hazard.

4 DATA COLLECTION ACTIVITIES AND PROTOCOLS OF THE EVALUATION FIELD TESTS

4.1 EVALUATION OF TRF

The objective of field data collection by paid drivers in support of the TRF evaluation was to have a series of structured driving activities over a route defined by a sequence of links. After the completion of each route, the drivers would pass through a staging area, where they received further instructions. The problems encountered in selecting the staging area and the route are discussed in this section.

Characteristics of the Staging Area. In order to properly coordinate driving activity, a staging area was necessary. The staging area needed to be close to the route (in distance and travel time) and of sufficient size that several probe vehicles could be parked at one time for short durations. The ideal staging area would be a quiet street just off the main route, where it would be possible to turn around safely and proceed back to the route.

After eliminating several unsatisfactory candidates, two principal staging areas were finally selected, one near a cul-de-sac with small office buildings and the other in a residential area. Research staff notified police officials in the municipality where tests were being conducted, and the law-enforcement community was made well aware of activities beforehand. However, concerned citizens called the police near both staging areas. There were no complaints from the businesses near the cul-de-sac. While most of the residents near the other staging area were curious and, after being briefed about the work and its purpose, very supportive of it, the members of one household expressed a strong desire for the tests to be conducted elsewhere. Although drivers were instructed to comply with the speed limit in the residential area (in fact, they drove slower than the other vehicles on the street), the additional traffic was not welcomed by some households. When activities were relocated to another residential staging area where approval of the neighbors in the immediate area had been obtained in advance, yet another unhappy home owner was encountered. His reaction was prompted by the presence of technicians who were called to check a few vehicles that were having problems with their MNAs. The home owner objected to the conduct of such testing and repair on the nearby street. When the repairs were subsequently conducted in an off-street open area away from homes, complaints ceased. In general, complications cited above were resolved without problems.

Characteristics of the Route. Several factors needed to be considered in defining the route used in the analyses. The route had to be sufficiently short so that a high density of vehicular coverage could be achieved. There were a variety of tests to be performed and each had its own requirements. The density of coverage could be varied by using different fleet sizes. The largest number of probe vehicles necessary was fifteen. These probe vehicles needed to travel a route that included a variety of link types, loop detectors for signal actuation, and detectors for volume and

occupancy data. The arterial selected (Illinois Route 68, shown as Dundee Rd. on Figure 2) had detectors at all of the key intersections, but the detectors recording volume and occupancy information did not provide coverage that would have been considered optimal for data collection. For example, it would have been desirable to have detectors collecting volume and occupancy data for two sequential or at least closely separated blocks along the same roadway to permit link-to-link correlation of data. However, one of the project's goals was to rely on the utilization of existing systems for additional input to the TIC. This being the case, major changes to the normal "closed-loop" signal system and detector configuration on Dundee Rd. were not undertaken.

Given the elements described above, actual choices were very limited. Some prospective routes were very long, not in distance but in travel time. For example, the link on Dundee Rd. just east of Illinois Route 21 (shown as Milwaukee Rd. in Figure 2) looked very promising, but during the peak period, it was so congested that more than five minutes were typically required to complete a traversal. The other problem with this link was the lack of a safe place to turn the vehicles around.

Approximately 60,000 miles were driven in urban traffic. Driver safety was very important — hundreds of routes would be driven each day. There was to be a basic route and another for conducting tests on turning relationships. The initial expectation was that a selection would be made from several alternatives. In reality, it was impossible to identify a route that met all expectations. Thus, the process of choosing a route ultimately eliminated, for one or more of the reasons discussed above, all but the route that was selected. With a much larger driving fleet and a smaller range of tests, a broader final choice of routes would have been available.

4.2 DRG/YD AND ID EVALUATIONS

A typical day in the TIC during the DRG/YD and ID tests began at 2:00 PM. Drivers signed in and were assigned vehicles for the yoked test or chose a vehicle for the ID test. Route assignments and any other special messages or instructions were given. Generally the drivers were on the road by 2:30 PM. Vehicles were tracked and drivers were called if MNA reports were not received every 10 minutes. When called, drivers were asked about their MNA and traffic conditions. A decision was made in the TIC as to the likelihood of a probe reporting malfunction, and drivers were given instructions to reset the MNA if there appeared to be a malfunction or to standby otherwise.

For the YD test (vehicles starting at identical times over the same route), probe vehicle drivers were divided into six teams of two or usually three (dependent on driver or vehicle availability), plus two dynamic yoked vehicles and one static yoked vehicle. Each driver was given a booklet of route plans that showed each origin-destination (OD) pair, the staging area for each run, and the route to be taken. Captains were appointed for each team; each captain was given a form that listed dispatch times for each team at each OD pair. A field manager, appointed for the test, was present on-site to start the test for each assigned OD pair and to oversee the dispatching of probe and yoked vehicles. The field manager used a watch synchronized as closely as possible with the TIC

clock to determine the time for each test start. This time was also recorded in the TIC by the test manager. The field manager and all drivers were in contact with the TIC by cellular telephone.

When each driver finished a run, he or she called the TIC, and the finish time was recorded. Precise recording of the finish time was not critical for the test; however, early in the process it provided feedback on whether the route start times and lengths were appropriate. For example, yoked vehicles arriving well before some of the probe vehicles would be an indication that the probe vehicle launch time may have been designed to start too late. Calling in the finish time also established a communication channel between each driver and the test manager and served to improve driver performance and consistency.

Staging areas for the DRG tests were different from those for the TRF validation tests because that 21 or more vehicles were involved. This larger number required larger staging areas and advance permission from property owners to assure that the *ADVANCE* vehicles would be accepted. Vehicles were staged in parking lots of forest preserves, schools, and shopping centers of various sizes. In the case of school lots, prior arrangements for use were especially important because, on occasion, the timing of yoked driver tests placed 21 vehicles in a school lot while the school was still in session.

The choice of staging areas had a direct effect on the actual routing of yoked vehicles in the case of certain OD pairs. For example, when vehicles were staged in a large shopping center at the intersection of two major arterials, drivers might be routed into traffic by one of three or four exits separated by some considerable distance. In at least one case, some of the routes followed arterial streets at the edge of the subnetwork in which the OD pairs were laid out, and included local "collector" links not adequately covered by probe vehicle travel time reports. This situation suggests a need for careful on-scene supervision to understand exactly where drivers are staging and what routes they are following in and out of staging areas.

For the ID test, a computer log file was electronically transferred from the Northwest Central Dispatch (NWCD), a computer-aided police, fire, and ambulance dispatch center serving six communities in the middle of the *ADVANCE* test area. This file was monitored in the TIC to identify incidents deemed appropriate to observe. When an accident with injuries or accident with property damage occurred in the vicinity of the driver assignments for the day, the test manager called the appropriate driver, asked for his or her location and, if they were close enough, sent the driver to the incident location. The test manager fielded calls about the existence of the incident and the nature and location of the incident if it was sighted. The test manager then gave the drivers further instructions about the traversals they were to make. It was helpful to listen to the NWCD dispatcher's band on the radio because often a more specific location or description of the incident was available. Logs were kept of each incident observed, both in the TIC and by the driver. At 6:45 PM, drivers were instructed to call the TIC to receive directions about finishing their routes and returning to the TIC. Drivers returned to the TIC between 7:15 and 7:30 PM. Upon their return, the test manager made sure appropriate forms were submitted.

4.3 REAL-TIME DATA RETRIEVAL TRACKING

Both the evaluators and the evaluation manager maintained procedures to minimize data loss while field tests were in progress. A set of forms for real-time “hard-copy” recording of information was developed to assure post-test capability to trace the time and cause of specific events having the potential to disrupt or even invalidate data collection. A tracking check-sheet was used to assure that probe reports from vehicles known to be active were arriving at the TIC at acceptably short intervals. If an automated report from a given vehicle had not been received at the TIC for 7 or 8 minutes, its driver was contacted by cellular phone to determine if a problem had developed. The tracking form was supplemented, if vehicular or system problems were encountered, by a “problems” log book entry for that day. Paid drivers for the TRF tests also maintained daily running logs, which were used to record specific run durations, as well as to document unusual occurrences, such as railroad grade crossing delays, signal cycle failures due to congestion, or other events that precluded completion of a route according to a stipulated test procedure. The logs also indicated when the drivers believed they had lost functionality of the in-vehicle navigation unit or were otherwise out of communication with the TIC.

Data forms for yoked vehicles in the DRG/YD tests showed the routes the vehicles had taken and any reroutes. (The test start and finish times for each vehicle were also recorded on a form in the TIC.) For the ID test, the data forms were a reconnaissance form and an incident form used by drivers and two forms used at the TIC. The reconnaissance form was used by drivers to record the location, date, and roadway impacts of construction activity. The incident form was used to record the date, type, and location of incidents that were observed by drivers. The test manager in the TIC used the incident data form to record NWCD log number, vehicles assigned, type, and date and time of incidents observed; the test manager recorded dates and link locations of planned construction lane closures on the construction data forms. A form that listed vehicles, drivers, and assignments was also completed in the TIC for both the DRG and ID tests.

4.4 DATA CAPTURE AND ARCHIVING: DAILY TEST LOGS

The complete set of daily logs of all electronic reports received by and dispatched from the TIC for each test day (covering the period approximately 6 AM to midnight) — MNA reports, loop detector reports, NWCD incident reports, TRF messages (travel time projections), and DGPS corrections — were retained on disk storage media on the TIC computer. Early on the morning of the next day, a process was automatically initiated to compress these logs into a tar_gz file, which was transmitted via a T3 telecommunications link to a data server/host at Argonne. The Argonne server automatically uncompressed the tar file and wrote the complete set of logs for the preceding day to a password-protected data page as the files for the current calendar date (the data page entries for “September 22” would all be September 21 field data). Time stamps were retained for all log records, permitting evaluators to re-create project vehicle routes, route sequences, and contingent events according to a precise chronology. Data on the Argonne server were made available by

Internet FTP or http links to remote locations where the evaluators conducted downloading and analysis.

4.5 DATA CAPTURE AND ARCHIVING: MEMORY CARD FILES

Every Friday during field tests, the PCMCIA cards containing link traversal data recorded on board each vehicle were removed from the project vehicle MNA display heads by project office staff and downloaded by card reader. None of these cards ever exceeded or even approached its 2-MB (formatted to 1.44 MB) capacity over a week of testing. In addition to time-stamped link traversals, the cards also recorded vehicle position at two-second intervals as referenced to a map grid developed by Motorola. These binary-coded files were converted to ASCII at the TIC, then both the original binary and new ASCII files were transmitted electronically to Argonne. The ASCII files were installed weekly on the data page as dated entries in a special subdirectory.

4.6 FAMILIAR DRIVER DATA COLLECTION INSTRUMENTS

Continuous monitoring of vehicle movements was neither necessary nor desirable during the two-week periods in which drivers familiar with the roads system in the *ADVANCE* test area used MNA-equipped project vehicles based at their respective residences. However, these drivers were asked to complete three different types of information recording instruments as part of their agreement to participate in the program:

1. Baseline survey, filled out prior to receiving a project vehicle, providing the characteristics, driving experience, and previous use of traffic information services (e.g., radio, cellular phone) of each participating driver (up to 2) in the household;
2. Re-route logs, to be filled out during the two-week period at any time that a driver decided not to use an *ADVANCE*-system-provided route or received an alternative routing option while following an MNA-preplanned route; and
3. Exit survey, recording each driver's overall end-of-test response to and reactions about the two-week route guidance experience.

Obtaining the completed first instrument was quite trivial in that no household would be issued a vehicle without it. Thus, data capture was 100 percent. Of 80 households participating, 74 completed at least one re-route log, while a few completed as many as 20. Obviously, there was no way to verify that all re-routes were recorded by each of the 74, or that no reroutes were actually presented to or undertaken by the remaining 6. Finally, 78 of the 80 households returned the exit survey.

5 EVALUATION DATA COLLECTED AND ARCHIVED

The following electronic data files were captured *daily* during the targeted deployment field tests and used subsequently by evaluators in support of their analyses.

mnarep.log (date): the previous day's link traversal reports by probe-equipped vehicles (including those not directly involved in the evaluation tests but which were used in updating the static profile), listed chronologically by MNA time stamp. Northwestern University used a version of this log specially modified by Argonne that incorporated the street name of the link and the historical (static profile or base data) average travel time estimate for that link at that time of day.

dundee log, tsc log (date): the previous day's five-minute average volume and occupancy estimates from, respectively, the Dundee Rd. (Ill. Route 68) and Traffic Systems Center (freeways) detector master controllers. Northwestern University used a specially modified version of these logs that provided one-minute estimates.

msgsch (message scheduler).out (date): raw output of all of the previous day's four-second message bundles, containing link travel time updates and GPS range corrections transmitted to all probe vehicles, ordered chronologically by TIC time stamp (these are very large files).

nwcd.out and incidentTracker logs (date): raw and operator-processed descriptive records, respectively, of the previous day's emergency vehicle dispatches by incident type and (subsequent) incident closeouts in the Northwest Central Dispatch area — covering a large portion of the *ADVANCE* study area — organized chronologically by TIC time stamp.

shortLinkResolver log: chronologically-ordered instances of execution of the short link resolver to explain an “impossible” link traversal (i.e., a very low traversal time or an instance of disconnected links in consecutive probe reports); this information was needed occasionally in reconstruction of probe vehicle routes.

tsc0.out: raw freeway detector report data from the Traffic Systems Center. Rarely used.

ttp.out: output of the travel time prediction algorithms from probe and, as applicable, detector data, used to generate 5-minute-interval link travel times estimates for the current, the 5-minute-ahead, the 10-minute-ahead, and the 15-minute-ahead intervals; used by UIC-UTC during its evaluation of the performance of the traffic-related functions.

ssi.out: weather forecast output. Rarely used

dataServer log: used during the TIC architecture evaluation to track server up time and on-line functionality; also could indicate TIC instability.

The following data from the on-board PCMCIA memory cards were captured *weekly* from late July onward during the targeted deployment field tests and used subsequently by evaluators to complete their analyses:

- Link traversal file (listed chronologically by the modem identifier uniquely assigned to each probe vehicle) containing the travel time report and hexadecimal link identifier (plus actual street/segment name as translated by Argonne).
- Location identifier messages (in Motorola-supplied coordinates translated to latitude/longitude datum) written every two seconds by each probe vehicle's MNA.

All manually recorded instruments from the familiar driver tests — baseline surveys (130), reroute logs (74 sets, or about 400 individual logs), and exit surveys (110) — were coded and uploaded to the data page for ease of tabulation by NUTC staff.

Data capture and archiving were generally successful from early June through August, despite the brutal heat on most test days; after the overheating problems with the CD-ROM drives were mitigated, the only systematic log data losses occurred on those few days when the TIC went down for brief periods or was not properly started in the morning (resulting in the daily log storage process failing to execute and null files being generated for some logs). In most cases, after July, data lost in this manner could be reconstructed from memory card files.

Archiving success was somewhat more uneven during the autumn months. At one point in late September, both a loss of log data and a malfunction of PCMCIA functions in one or more vehicles (plus a possible failure to download data from one vehicle's card for a particular week) resulted in irrecoverable loss of some electronic yoked vehicle test records during the incident delay simulation phase of the DRG evaluation. Thus, much of the incident simulation portion of the DRG tests ended up relying on manually collected driver logs for route timing information. There was also electronic data loss in November during the post-construction traversal time follow-up field tests for incident detection, but consequences of this loss were somewhat less critical than for DRG.

Both the daily field test logs, filed by (following day's) calendar date, and weekly memory card data, filed by vehicle modem identifier, are currently retained in compressed (tar_gz) form on a data sub-page of the *ADVANCE* Web page, accessible by user password. In due course, when all evaluators and the *ADVANCE* partners have completed the analyses they expect to perform using these data, the Steering Committee will approve opening the data page, with appropriate annotations, to access by the research community at large. It is expected that this will occur by January 1997.

6 LESSONS OF THE PARTNERSHIP AND THE TARGETED DEPLOYMENT TEST PROCESS

Four years of cooperative project experience and system development followed by seven months of field evaluation posed a wide variety of technical and management challenges for *ADVANCE*, alongside of which was the ongoing evolution and growth in understanding of public/private partnerships. The project's colorful and illustrative history has contributed valuable insights into approaches that are effective, and those that are less than satisfactory, in the deployment of an ATIS. We summarize below some of the most instructive of these insights.

All parties involved in the *ADVANCE* project had prior experience in related efforts. However, no one had the experience in all facets of such a project or in large-scale technology development and implementation efforts involving a *public-private partnership*. All of the parties to the *ADVANCE* Agreement of 1991 committed significant resources to the project and worked diligently in a spirit of cooperation, which was evident not only in technical areas but also in the commitment of public information, audit, and administrative staff brought into *ADVANCE* by the parties. As events transpired, without this degree of commitment by all parties, the project might well have failed and thus retarded both the prospects for and promise of public-private partnerships in transportation. Nevertheless, arduous efforts among project management staff and all public and private sector participants were occasionally necessary to resolve complex and delicate issues: such a development must be anticipated for any public-private partnership deployment.

ADVANCE had much in common with applied research, in addition to systems design. (Research often requires a creative process that is not conducted on a rigorous schedule, as much as managers wish to the contrary. This is especially true of the conceptual stages of a project.) *ADVANCE* applied the time-honored management structure of dividing large tasks into smaller subtasks and even sub-subtasks. The general experience with *ADVANCE* can be summarized by stating that more aggregated techniques proved to be more acceptable to designers than more detailed techniques. Given a milestone chart that highlights interfaces between parties, a group of project leaders could better visualize the task, discuss deadlines, and progress towards them in a meaningful way. However, it remained open to debate whether the more detailed description of tasks provided any useful insights or measures of progress. As with any administrative process, excellent communication and explicit, even-handed application of procedures can help facilitate resolution of the difficulties of this unusual institutional format.

Some general observations about management of public/private enterprises gleaned from the *ADVANCE* experience are as follows:

- Ensure that the project manager's role is distinct and separate from those of project partners;

- Take all necessary measures to retain key project leaders and legal and financial personnel from the point of project conception to its completion and require each participant organization to designate a certain position responsible for executing all contractual documents;
- Fully develop and understand all procurement processes with commercial enterprises before executing an agreement and ensure that the project adopts procurement and audit procedures meeting the internal requirements both of a private sector firm (with a commercial focus) and of governmental agencies (with a regulatory focus); and
- Organize administrative-type committees among the major parties to handle important non-engineering issues.

In developing an integrated ATIS involving an information center processing data streams in real time, an in-vehicle guidance system, and continuous center-to-vehicle communications, it is appropriate to (a) assure early and constant communication among the designers and developers, (b) develop standard guidelines for documentation that will be followed throughout any project, especially one of size and complexity comparable to that of *ADVANCE*, (c) assure access by system developers to information related to all subsystems, even if some subsystems contain proprietary information, (d) ease complexity of the integration testing effort by “freezing” the system release level while integration is occurring (i.e., perform all of Release 1 testing for all subsystems before proceeding to Release 2, and avoid “interim” releases of component subsystems that are out of synch with other subsystems), (e) thoroughly test all subsystems before they are submitted to integration testing, (f) design into the development process a channel to provide input and feedback from operations personnel so that designs do not proceed in an inappropriate direction, (g) ensure that system integrators have the capability to examine internal data flows and data values during testing, and (h) record and track any problems not fully resolved and requirements not met during testing.

The design of large demonstrations similar to *ADVANCE* should reflect what can be done with existing technology, rather than emphasizing the use of unproven technology. A specific example of this design philosophy in *ADVANCE* was the unavailability of low-cost, high-speed, industry-standard equipment to serve MNA/TIC communications during deployment. In the targeted deployment scenario, a 4,800-bps system was adequate. However, performance of this carrier technology, like that of some other subsystem components, would have been inadequate under full deployment. Hence, *ADVANCE* needed to make provision for a high-speed system during the development phase of the project. It is likely that technologically advanced integrated systems would have been needed under full deployment to enable the vehicles to function reliably in the wide range of environments encountered by moving vehicles and to meet high standards for vehicle positioning accuracy.

In carrying out field tests using hired drivers, unexpected situations are likely to occur. Whenever paid staff must be procured, problems will arise because of the time limitations in getting all particulars finalized, especially those relating to liability insurance coverage. Resolution of insurance issues should be given the highest priority before field testing protocols and schedules are finalized. Paid drivers for specific tests should be hired on the basis of an interview conducted no later than a few weeks before the start of the test. Other means of recruitment evaluation are likely to prove less satisfactory. With respect to vehicular resources, ensure before testing begins that availability of test vehicles will match the requirements of the test(s) to be run on any given day; account for vehicles scheduled for maintenance and repair under tracking procedures like those adopted for *ADVANCE*.

If vehicle staging areas are located in residential areas during field tests, it is not likely that all potential objections from neighboring residents can be anticipated and allayed in advance. Nevertheless, prior clearance with local law enforcement and directly affected institutions (school, shopping areas) is essential for both logistical and diplomatic purposes. Moreover, even after testing begins, there may remain the need for careful on-scene supervision to know exactly where drivers are staging and what routes they are following in and out of staging areas.

Written logs should be maintained to document unusual events during field tests: paper trails are vital to attempting after-the-fact diagnoses of operational problems that resulted in lost or corrupted data. Where electronic data collection is used, a backup automatic data retrieval system should be considered for critical field testing.

While the quality of probe link traversal data reporting in the *ADVANCE* tests was very high — indeed, such data proved a more reliable basis of real-time travel-time estimation and prediction than data from arterial loop detectors — the quality of prediction of arterial travel times could be increased even more by including data on the timing and phasing of traffic signals. This finding may provide guidance for algorithm development for future ATIS deployments. However, such algorithm development must take into account the facts that probe-vehicle travel-time reports are not independent, (the condition of statistical independence is assumed in developing most statistical formulae), that travel times themselves are highly stochastic, and for some computations, the effects of nonindependence of reports and large variances in values for a given link can be great.

For tests involving volunteer drivers who will operate either project vehicles or their own vehicles as part of a test and later complete surveys, any pretest agreement should stipulate an explicit reward for timely completion of or penalty for nonresponse to survey instruments; otherwise, it is almost certain that the post-test survey response rate will fall short of 100 percent of the data base target. Moreover, never assume that in all prequalified, two-driver households, both drivers will drive the vehicle, unless instructions and incentives are offered to ensure that both drivers will participate in the test. Even if all households selected were two-driver units, it appears that only about 1.4 drivers per household will actually participate unless special steps are taken to ensure each driver uses the vehicle.

Volunteer driver recruitment involves a different set of considerations than paid driver recruitment and, depending on the number of volunteer drivers involved, may well require substantial resources and planning up-front to execute effectively. Focus groups and surveys can be effective tools in designing experimental conditions and participation agreements. Both paid and free advertising well in advance of testing will be required for volunteer solicitation, and specific attention to the content of solicitation materials is necessary to avoid under-representation of women, older drivers, and the physically challenged. Application forms and driving record checks are advised to ensure that candidates meet sampling and screening criteria. The recruitment process should be implemented by a knowledgeable and efficient single-point-of-contact agency representing the interests of all participating parties. The agency should employ an efficient and responsive computer data base for contract management in any test involving a large number (hundreds to thousands) of volunteer drivers. With respect to orientation of volunteer drivers, it was found in *ADVANCE* that one-on-one training in test vehicles quickly prepared the drivers for safe and efficient use of the MNA system.

In *ADVANCE* the paid driver field tests preceded those in which local residents (volunteers) used the project vehicles. Thus, virtually all system operational problems could be resolved prior to the time period allocated for most of the public use of the vehicles (i.e., by the volunteer drivers). It is recommended in future evaluations using a single set of equipped vehicles for both focused tests and more general public exposure applications that all paid-driver-system verification testing be completed before turning project vehicles over to volunteers.

The *ADVANCE* MNA-based route guidance system was found to be at least as safe as, and possibly safer than, use of paper maps or a typed list of instructions for drivers both with and without prior experience using the in-vehicle display. This finding was based on the comparative number of driver errors and "near misses" (driving proximate to a hazard present in the roadway environment) observed under each means of navigation by trained experimenters who accompanied these drivers in an MNA-equipped vehicle. However, no benefit to driver performance was observed by the auditory (voiced instruction) supplement to the MNA display, a finding which departed from that of at least one prior study (the TravTek demonstration in Florida) in which the auditory cues, while acoustically and aesthetically less pleasing than that of the *ADVANCE* MNA, did increase driving and navigation performance. Thus, there is evidence that designers of future ATIS navigation systems should devote further effort to exploration of the effects and value of voice message content, aesthetics, and timing, and their relationship to driver performance, safety, and preferences.

The design and implementation of ATIS projects will require people of profoundly different disciplinary backgrounds and even greater variations in institutional settings (corporate, government, and university) to work together cooperatively and effectively. Effective collaboration requires the institution of a defined committee structure; in *ADVANCE*, such a structure — the System Issues Subcommittee — was in place for purposes of algorithm development. This body ensured effective collaboration and, when necessary, enabled successful decisions to be made focusing the combined

resources of all partners on commonly agreed objectives. In general, development of *ADVANCE*-type multicomponent algorithms should be based on the use of a unified structure, preferably based on field rather than simulation data. However, it is reasonable and appropriate to use simulated data as a preliminary starting point, subject to validation and refinement when field data become available.

The *ADVANCE* development plan called for *parallel* development of the technology and the algorithms that would make the technology useful to drivers, and during much of the project, development did occur concurrently with implementation. While performing tasks simultaneously rather than sequentially enabled more rapid completion of the project than would otherwise have occurred, it also created difficulties. One such impediment to development of the travel-time algorithms was a lack of actual probe data for algorithm development, refinement, and validation prior to the commencement of testing. Future development programs should allow adequate time for such data collection, with the full technology in place, before finalization of the algorithms that will interpret data for traffic analysis.

Nothing revealed by the *ADVANCE* field tests refutes the conclusion reached in prior studies that reliable real-time information during periods of *nonrecurring* congestion has a very high value and usefulness and thus should be a key component of ATIS deployments similar to *ADVANCE*. To maximize the probability that real congestion reduction (and associated emissions improvement) will result from an ATIS deployment, the system should (a) communicate accurate information on link traffic conditions to ATIS users with the shortest possible delay and (b) offer an accurate, reliable route planner. In addition, would-be purchasers of ATIS services need to be convinced that real, measurable benefits *will* accrue. The road network in which this system is to operate must possess alternative route options that are faster and not too much longer (significantly greater length can mean higher emissions) than the original route of choice and that generally have excess capacity (mitigating the problem of diverted congestion). In general, the gap between system *potential* and actual system *performance* must be closed before the confidence of ATIS users can be won sufficiently to make them act consistently on ATIS guidance.

ADVANCE was able to achieve its basic goals at significant savings in time and money by adopting the targeted deployment strategy. As conditions changed from those in existence at the time of signing of the original agreement, project management and the project Steering Committee remained vigilant and appropriately redirected effort to achieve an overall benefit from the project, even though specific development targets were at least temporarily abandoned in favor of more promising and better-informed evolving projects. Given this experience, *ADVANCE* established that the use of a multiple decision point framework as a project progresses should be considered in all major operational tests.

7 THE EVALUATION TEST REPORTS: A SYNOPSIS OF FINDINGS

Eleven evaluation test reports and a twelfth report comprising a compendium of “insights and achievements” white papers were prepared under the evaluation test plans co-developed in May 1995 by Booz•Allen & Hamilton and the evaluation teams at the UIC-UTC; NUTC; and DeLeuw, Cather & Co. This section summarizes the salient findings of the 11 test reports. Details regarding the design of each evaluation, the structure of field tests, and resulting data analyses are contained in the reports themselves, which are appended to this overview document.

7.1 BASE DATA AND STATIC PROFILE (#8460-01) (APPENDIX A)

The purpose of the base data and static profile evaluation was to assess the quality of the base data of link traversal times, estimated by simulation using a Network Flow Model (NFM), and the quality of the (approximately quarterly) static profile (SP) updates of these traversal times, estimated with actual probe and loop detector data collected at the TIC. Validation of both the NFM and the SP was based on data from a representative sample of links by comparing probe data to corresponding (time-of-day) values in the NFM and SP, respectively. In general, there was inconsistent correspondence between peak and off-peak traffic volume estimates as provided by the NFM and by the actual arterial traffic volumes recorded by in-pavement detectors, due to a wide variation in the quality of the NFM estimates (good to very poor) of speed and travel time on the subset of study area road links analyzed. The discrepancy was attributed to either inappropriate cost functions in the NFM or obsolescent origin/destination counts (which were based partially on 1990 data). Whatever the reason, it was found that, especially after a few updates, SP values for the same links were exceptionally accurate. The updating algorithms performed robustly against occasionally idiosyncratic probe reports. Profiles based on probes only were found to be more accurate than those based on both probes and traffic signal system detectors. Analysis results indicated that a recommendation to modify the SP algorithm into a continuous, rather than stepwise, function incorporating data on traffic signal timing would be appropriate for future applications.

7.2 DATA SCREENING (#8460-02) (APPENDIX B)

The purpose of the data screening (DS) evaluation was to assess the performance of the screening tests for on-line probe and detector data within the data fusion function. The goal of these components is to remove probe and/or detector reports that are unreasonable, probably attributable to malfunctioning detectors of MNAs, and/or inconsistent, attributable to the presence of incident conditions, according to preset criteria for acceptable minimum and maximum values. In order to test that these components were properly implemented in the TRF design, their limits were tested with simulated data. Then the actual performance of the algorithm was tested using real probe and detector reports. For the simulated data, the DS algorithm performed as designed. For actual data,

there were several instances in which a report failed the screening test for inconsistency but no incident was present. However, in most of these cases, a malfunction of the MNA reporting process had apparently occurred. The overall screened-data-consistency success rate was 99% for probe reports and 92% for arterial detector reports. It was concluded that, while performance of the DS algorithm was not satisfactory with respect to identifying incident conditions on arterials, the DS screening was very effective in identifying the rare occasions when MNAs malfunctioned; for this reason its use was continued because the resulting data base was better with it than without it. Among recommendations for modifying the DS algorithm were (a) apply lane volume rather than total approach volume, possibly by dividing total approach volume on a link by the number of mid-block lanes as reported in the attribute data base and (b) relax the testing criteria for screening detector data consistency but tighten the restriction on maximum (permitted) probe link travel time.

7.3 QUALITY OF PROBE REPORTS (#8460-03) (APPENDIX C)

The purpose of the quality of probe reports evaluation was to systematically compare probe-reported values with “reasonable” values for each link and also with manually reported travel times and congested distances (distances traveled and speeds of 2.5 m/s [about 5 mph] or less). Some 50,620 probe reports were collected and examined, of which 88 had unacceptably high speed, 95 had unacceptably high congested distance (longer than the link itself), and 115 had an unacceptable match between congested distance and congested time (i.e., time on the link spent at speeds at or less than 10 m/s [about 22.5 mph]). Of these latter 115 reports, 11 were also in the set of unacceptable speed reports. Thus, 287 reports were found to be suspect, or about 0.6 percent of the total, and many of these were traceable to a single faulty MNA. Further, when 776 of these probe-reported values were compared to manually recorded values observed for link travel times, 87.6% of the probe values were within plus or minus five seconds and 94% within plus or minus ten seconds, with substantial clustering within two seconds or less. The overall conclusion was that MNA data as deployed in *ADVANCE* proved a reliable indicator of traffic conditions and thus could provide a valuable resource for traffic monitoring and analysis in future ATIS deployments.

7.4 TRAVEL TIME PREDICTION AND PERFORMANCE OF PROBE AND DETECTOR DATA (#8460-04) (APPENDIX D)

The purpose of the travel time procedures evaluation was to assess the quality of the travel time prediction (TTP) algorithm, which used both probe and detector data to generate link travel time estimates for each of four five-minute intervals: the current interval, and each of the three intervals beginning five, ten, and fifteen minutes into the future. Values of these predictions on four links of the study route (see Figure 1) were compared to actual electronically recorded travel times experienced by paid drivers, and the sensitivity of prediction accuracy to varying levels of probe deployment was also examined. Two links with detectors were selected for detailed examination. It was found that both detector and probe data performed reliably as a source of input to the

algorithm during the off-peak period, but during the peak period the arterial detectors, whose primary function, as mentioned above, is to regulate traffic signal timing, quickly became saturated (i.e., overloaded with vehicles stopped in the queue spilling back from the link ahead) and yielded unreliable travel time predictions. Probe-based predictions were more accurate, but during peak periods, the probes also substantially underestimated actual travel times. This suggests that the prediction algorithm may have been calibrated too conservatively (i.e., somewhat too willing to ignore clusters of high probe travel time reports). Appropriately, the algorithm does ignore outliers when only one or two appear in a five-minute interval, and thus generally performed well in such circumstances. It was also found that in most instances, predictions changed substantially from one to three probe reports per five-minute period but changed very little with increasing numbers of probe reports. This finding is consistent with that of the frequency of probe evaluation (see below).

7.5 DETECTOR TRAVEL TIME CONVERSION AND FUSION OF PROBE AND DETECTOR DATA (#8460-05) (APPENDIX E)

The purpose of the detector travel time conversion and fusion of probe and detector data evaluation was to assess the quality of travel time estimates obtained from detector volume and occupancy observations and those obtained from the fusion of probe and detector data. This assessment was accomplished by comparing the detector-based and fused-data travel times to averages of probe reports over five-minute intervals. Performance of two algorithms was examined: that of the process that converted detector data to travel time estimates (detector travel time conversion or DTTC) and that of the process that fused these estimates (data fusion or DF), when available, with probe data to create link travel time updates for incorporation into the static profile. The evaluation examined only data from links on which the probe deployment level during the periods of interest were at least five vehicles per five-minute interval, in order to ensure a reasonable basis for computing mean probe travel times. The analysis showed that estimates of arterial link travel times produced by DTTC and DF appeared to be accurate except when over-congested conditions were present over a long period of time. This shortcoming was likely attributable to the saturation and “spillback” problems cited above. More data for calibration purposes would have been necessary to improve the performance of DTTC. With respect to DF, estimates for steadily increasing deployment levels (i.e., using probe traversal times based on one-, three-, and five-vehicles per interval means, respectively) suggested that the greatest improvement in fused data estimates when compared to DTTC alone occurs from a one- to a three-vehicle level, with considerably less net improvement between the three- and five-vehicle levels. However, *even one probe traversal per five-minute interval yielded more reliable travel time estimates than did DTTC output only*, especially in prolonged congestion conditions.

7.6 FREQUENCY OF PROBE REPORTS (#8460-06) (APPENDIX F)

The purpose of the frequency of probe reports evaluation was to determine whether a high frequency of probe link traversals would be *required* in order to obtain reliable estimates (and near-term forecasts) of travel times. In order to do this, a correlation function of travel times for links of the test route (Figure 1) by time of day and headway at various probe deployment levels was derived with a view toward estimating and analyzing travel time variances, while recognizing the statistical nonindependence of probe reports on the same or contiguous links in a given time period. A synthetic method to get around this lack of independence was devised to estimate the relationship between estimate quality (as measured by probe time variance) and the number of probe reports per time interval. It was shown that the variance of estimates never approaches zero regardless of the number of probes, and that the quality of estimate essentially stops improving at the point of a relatively few more traversals per five-minute interval. These two factors argue strongly that *very high levels of probe deployment are probably not necessary for an effective probe-based ATIS*, and that the approach taken with *ADVANCE* travel time algorithms — namely, not broadcasting update messages until dynamic estimates differ by a conservatively large margin from the static profile estimates — was appropriate for this deployment. Nevertheless, had signal timing data and the exit times of probes departing links been included in the algorithms used, the quality of estimates and thus of route guidance would have been considerably enhanced. Incorporation of these data into calibration procedures for travel time prediction functions is strongly recommended for future probe-based ATIS deployments.

7.7 RELATIONSHIPS AMONG TRAVEL TIMES (#8460-07) (APPENDIX G)

The purpose of the relationship among travel times evaluation was to investigate whether a systematic and identifiable relationship between through- and turning-movement travel times exists on arterial links by time of day (inferred traffic volume) and, if so, how it might be more effectively incorporated into travel time prediction for turning movements (in the absence of probe data) than the technique used in *ADVANCE* of adding a simple constant to the through travel time stored in the base data as computed by the NFM. Probe data of through and turning movements from one specific link on the test route (Figure 1) were intensively examined. Although this analysis was limited by lack of data on such relevant traffic variables as static profile update traversal times, flows on intersecting streets, protected left turn signal timing, and driver use of yellow and early red signal time to complete turns, the analysis showed that, in general, either applying a single constant value or adding a constant to the through travel time provided an adequate, but not uniformly reliable, estimate of turning travel time for the *ADVANCE* deployment, and in any case, the application of a more complex approach, such as a regression model, was not justified on the basis of the data analyzed.

7.8 EVALUATION OF ARTERIAL PROBE VEHICLE, FIXED DETECTOR AND EXPRESSWAY FIXED DETECTOR INCIDENT DETECTION ALGORITHM (#8461) (APPENDIX H)

The purpose of the arterial probe vehicle, fixed detector, and expressway fixed detector incident detection algorithms evaluation was to assess the quality and effectiveness of the procedures instituted in *ADVANCE* for flagging the presence of recurrent and non-recurrent roadway conditions leading to intermittent congestion and delay. Separate detection algorithms had been implemented for incident detection on *ADVANCE* study area freeways and arterials. Both algorithms used volume and occupancy data from in-pavement detectors, but the arterial algorithm was supplemented by probe data and verified in part by anecdotal incident reports from an emergency vehicle dispatching center (Northwest Central Dispatch). The freeway algorithm was a modified version of a procedure already in use in California that, once triggered, employed a decision tree sequentially categorizing observed detector-based states of traffic flow (key variables being the spatial and temporal differences between upstream and downstream detector occupancies) into a confirmed or tentative incident, or a compression wave. The arterial detector-based algorithm was estimated on a discriminant function employing the standardized values of the respective standard deviations of occupancy and volume at each detector. The arterial probe-based algorithm was estimated on a discriminant function employing link-specific ratios of, respectively, observed and mean average travel times and mean and observed average speeds. Parameter estimates for this function changed as the number of probe reports on the link during the possible incident time increased. Moreover, a Northwest Central Dispatch action could trigger an incident flag automatically.

In a limited test of the freeway-detector-based algorithm, the overall performance on the evaluated freeway (using parameter values estimated with data from another *ADVANCE* study area freeway) was generally poor, with a detection rate of less than 70 percent (with 1% false alarms) for a lenient false alarm penalty weight, declining to 20 percent (.02% false alarms) when the false alarm penalty was made stringent. However, the arterial fixed detector algorithm, which was subjected to more thorough testing, was modified following initially unsatisfactory performance to a formulation that detected 29 of 141 incidents with no false alarms. The probe vehicle algorithm based on the use of three sequential probe reports (in keeping with the adequate probe frequency identified in the various traffic-related functions test) identified 6 of 11 incidents without false alarms. A modification to this latter algorithm, which incorporated probe-reported congestion distance as a variable, improved this result to the detection of 9 of 9 incidents without false alarms. Thus, while the composite results of this evaluation call into question the generalizability of previously estimated freeway/expressway incident detection algorithms without complete recalibration of parameters for every expressway to which a given algorithm is applied, they reveal potential for further development of reliable arterial incident detection algorithms based on volume and occupancy data from fixed detectors and/or link traversal data from probe vehicles, a reliability which could in turn greatly enhance reliability of dynamic route guidance.

7.9 FAMILIAR DRIVER PERSPECTIVES ON *ADVANCE* AND FUTURE DYNAMIC ROUTE GUIDANCE SYSTEMS (#8462) (APPENDIX I)

The purpose of the familiar drivers evaluation was to examine the potential contributions of in-vehicle route guidance concepts to congestion avoidance in urban areas as evinced by the behavior and perceptions of, and valuation of *ADVANCE* follow-on concepts by, drivers resident in and familiar with the road network of the *ADVANCE* study area. Pre-screened volunteers representing 80 households in the area were given the opportunity to drive a vehicle equipped with the *ADVANCE* dynamic route guidance system (MNA) for a period of two weeks of normal use. A total of 110 drivers from these households used the *ADVANCE* vehicles and completed both baseline and post-test surveys as well as, in most cases, log forms recording each instance of and reason(s) for changing a planned route while driving; of this subset of drivers, 32 later participated in focus groups. The size of this population and the time frame point out the key limitations of the test: the test was based on a small, non-random, self-selected sample not (necessarily) broadly representative of the driving population at large or even within the study area; it took place over a very short time period; it could provide exposure only to limited functionality of the *ADVANCE* system; and it could only exploit real-time data generated sparsely and sporadically. Despite these limitations, a number of findings from the surveys, focus groups, and reroute logs provide consistent, logical, and potentially important directions for the development of future in-vehicle route guidance systems. Among these are the following:

- Drivers reported that routes provided by *ADVANCE* were not particularly good and tended to be inferior to their own routes; this conclusion is consistent with the facts that the drivers were very knowledgeable of the entire network, that relevant real-time information was not always available, and that the route planning algorithm, by policy, emphasized collector and arterial streets and avoided “local” streets in route plans, some of which the drivers commonly used for parts of their trips.
- Drivers generally expressed a preference for having a greater degree of control over their choice of routes and route planning criteria (i.e., having the route guidance system *learn* their individual preferences as part of its functionality), but the drivers also showed a high level of interest in real-time traffic information, especially that concerning non-recurring congestion, for the purpose of blending that data with their own knowledge to plan routes.
- The idealized vision of the route guidance technology expressed by most drivers was as an *intelligent assistant* that could acquire and process real-time data, use these data to *evaluate* routes chosen by the driver and, where appropriate, recommend alternatives to those routes *capable of saving time*.

- Focus groups and survey results each revealed patterns of gender and personality differences in response to (a) the route guidance function and user interface of the *ADVANCE* MNA and (b) preferences for future system attributes; the articulation of these perspectives and preferences was of sufficient depth and clarity to inform conceptualization and development of future route guidance systems capable of offering the *breadth* of capabilities (and sensitivity to differences) that a successfully marketable product will require. However, it was also found that the willingness to pay for such a future product or service was more clearly associated with the characteristics and overall experience of the drivers themselves, rather than with their assessment of the characteristics of the *ADVANCE* system.

7.10 FIELD TEST OF THE EFFECTIVENESS OF *ADVANCE* DYNAMIC ROUTE GUIDANCE ON A SUBURBAN ARTERIAL STREET NETWORK (#8463) (APPENDIX J)

The purpose of the dynamic route guidance evaluation using yoked (trip-start synchronized) vehicles was to determine whether, and the extent to which, DRG as implemented for the *ADVANCE* targeted deployment could provide useful route guidance to drivers on the basis of information about current travel times that differ non-negligibly from historic (average) travel times for that time of day due to recurrent or non-recurrent (incident-induced) congestion. The test utilized 18 probe vehicles for generating current link-travel-time estimates and three yoked vehicles, of which two were always capable of receiving real-time travel time and route guidance updates from the TIC (dynamic vehicles) while the third (except during the incident simulation phase of the tests, when all three were in RF communication with the TIC) had access only to data from the static travel time map on the CD-ROM on-board the vehicle. The 18 *ADVANCE*-equipped vehicles drove alternative routes between the start and end points of one of a set of five predefined (by arterial intersection) OD pairs in the study area. These routes were designed to provide coverage, and thus traversal time reports, for all links that might be part of a *reasonable* path between the selected OD pair. The yoked vehicles were then deployed from the origin at a common start time after a lag adequate to have received updated travel time information from the probe vehicles via the TIC. Drivers of the yoked vehicles manually recorded their travel time and route followed to destination; in most cases, this information was also recorded electronically on the MNA memory card. It was hypothesized that a successful DRG implementation would result, on average, in shorter OD travel times for a dynamic-equipped than a static-equipped vehicle, because in a significant number of cases the dynamic driver would be guided to a faster route.

In the actual test, 73 runs over the five OD pairs (at least 14 runs per pair) and 19 incident simulation runs, in which the probe vehicle drivers were instructed to slow to minimum safe speeds on defined links to simulate nonrecurrent congestion, were conducted over a five-week interval. Predominantly on the basis of driver-recorded information, dynamic vehicles were found to

experience significantly shorter mean travel times than static vehicles for two of the five OD pairs (t-statistic at 90 percent level or greater). For the other three pairs, mean dynamic times were greater than or equal to static times on average but not with comparable statistical significance. Examination of the limited computer data base showed that on three of the OD pairs, dynamic cars had statistically significant mean time savings for both (a) entire routes and (b) contiguous links that were part of each route. When comparison was limited only to cases in which the static and dynamic vehicles took different routes, dynamic time advantages were seen on four of five pairs (though none of these comparative results was statistically significant). Due in part to the need to maintain safe driving practice, incident simulation runs generated probe link traversal times that in many cases were not sufficiently different from the average times (i.e., around one minute greater) to trigger an update through DTTC and DF (see above), and thus for only one OD pair was a substantial proportion (76%) of yoked vehicle diversions off the incident link.

In general, the test established that route diversions and travel time savings are sometimes associated with the use of real-time data for route planning, but in an arterial network like that of *ADVANCE*, in which DRG is subject to key functionality limitations as cited above for the familiar driver tests, large time savings may not be a typical outcome. Where substantial time savings occurred during the test, the cause appeared to be availability of less congested (but, paradoxically, *longer*) links proximate to highly congested routes. *Such alternative routes, in the absence of DRG, are likely in most instances to appear illogical to drivers on the congested route and thus are unlikely to be found and followed without a route planner providing real-time information for the entire network.*

7.11 TIC ARCHITECTURE AND USER INTERFACE (#8464) (APPENDIX K)

The purpose of the evaluation of the architecture and user interface of the TIC was to assess the degree to which the implemented *ADVANCE* TIC architecture and operational practices met the needs of all agencies and users involved in or affected by the system operation. To achieve this purpose, several aspects of the performance of the various TIC subsystems were examined individually and collectively as a system, while the acceptability of the TIC console display unit was assessed in the context of the effectiveness of its user interface and responsiveness to human factors. A series of seven hypotheses about the TIC's performance and user interface as implemented was tested by determining in each case whether the TIC hardware and software had both met preset operational goals and shown the ability to meet objectives relating to expansion, transferability, and refinement of its capabilities and/or simplification of its architecture. The evaluation confirmed the following hypotheses:

1. The TIC architecture as implemented provided an acceptable level of performance for the demands made on it by the targeted deployment with respect to both hardware and software as individual components and as a complete system.

2. The TIC architecture as implemented provided an acceptable cost efficiency for the scope of its mission, an efficiency that could have been significantly improved only by having fully automated the TIC system.
3. The operational practices in place at the *ADVANCE* TIC during the targeted deployment test enabled successful system operation and ensured reasonable operator workload.
4. The user interface of the TIC as implemented provided an acceptable level of usability, although operator comments and suggestions for enhancement suggest that improvement is possible in many features of this interface.
5. The user interface of the TIC as implemented provided an acceptable level of functionality; certain functions as well as nonfunctioning display features that were almost never accessed by operators may be expendable in future system development, while some missing features that operators indicated would prove valuable to their capabilities should be added.

The following findings represent rejections of or modifications to pre-assessment hypotheses:

6. The TIC architecture as implemented for *ADVANCE* targeted deployment operational tests is not directly or immediately expandable to cover additional transportation management functions within the current test area because of inherent system limitations due to reduced project scope.
7. The TIC architecture as implemented for *ADVANCE* targeted deployment operational tests is not directly transferable to other geographic areas because it was a unique technical solution that, as an entire system, would have limited application and capability to meet local requirements in other areas; however, transferability of major system components is very likely.

8 THE EFFECTIVENESS OF PROBES: A KEY TEST OF THE TARGETED DEPLOYMENT

Its uniqueness as an ATIS, heavily dependent on probe-provided link traversal times for real-time information about travel conditions, made it incumbent on *ADVANCE* to establish whether GPS-locator-equipped probe vehicles can be a reliable and cost-effective source of data for developing such real-time travel time estimates and projections for an arterial network. If the *ADVANCE* experience has established the usefulness of probes, are any of the direct benefits to the relatively small number of (present and near-term) ATIS product users in probe-equipped (or even DRG receiver-only-equipped) vehicles transferable to other motorists in the network?

Bearing in mind the key limitations of the targeted deployment — (a) a TIC that was never stressed (except using synthesized data inputs during the TIC architecture evaluation) by having to process travel time estimation functions and RF messages at rates and volumes representative of a 3,000-probe deployment; (b) an in-vehicle guidance system whose planned functionality was not fully realized with respect to features or data processing rates; and (c) a study area network for which reliable average link traversal time estimates by time of day were not available for many arterial links in the static profile prior to the start of testing — the results of probe-related testing were nevertheless very gratifying, even exciting. As discussed above, of 50,620 probe reports collected and examined over almost three months of testing, only about 0.6 percent were found unreliable, and many of these were traceable to a single faulty MNA. Moreover, the great majority of the satisfactory 99.4% of reports provided traversal time estimates within 5 seconds of manually recorded values (themselves occasionally unreliable), with most of these falling within 2 seconds. Given the conservative modulation of the DF and TTP algorithms, such differences would be acceptably small to ensure consistent reliability in the generation of travel time updates. In the sequential updating process of the static profile, it was found that profiles based on probes only were found to be more accurate than those based on both probes and detectors. It was also found that in most instances three probe reports per five-minute interval are adequate to provide reasonable real-time estimates and predictions; increasing this probe rate produced very little change in the output forecasts — a result consistent with the statistical finding that the variance of link traversal time estimates never approaches zero regardless of the number of probes, and thus the quality of estimate essentially stops improving above relatively few traversals per five-minute interval.

These results argue strongly that GPS-locator-equipped probe vehicles *can* provide reliable data for developing real-time travel time estimates and projections in an arterial network and, because very high levels of probe deployment are probably not necessary, can do it cost-effectively. Thus, it is unequivocally recommended as a result of the *ADVANCE* analysis that traffic management agencies in large urban areas actively undertake to recruit a small population of commercial and private vehicles to serve as automatic vehicle locator (AVL) probes for operation

on arterials and expressways. Such AVL deployment has already occurred in the San Francisco Bay area and is being contemplated elsewhere. In this way, without the need for specifically identifying individual vehicles, a vital, generally unprecedented, and perhaps ultimately indispensable stream of travel time information for the *total* network would begin to flow into regional traffic support centers.

9 ARE THE TARGETED DEPLOYMENT'S RESULTS VALID AND TRANSFERABLE?

The decision to restructure *ADVANCE* as a targeted deployment meant that some of the project's original objectives were not fully met. A large-scale field test with 3,000 vehicles acting as probes was never realized. The scope of testing of DRG capabilities, the effect of the system on “familiar” drivers, and the ability to assess long-term operational and maintenance aspects of the system were far more limited than the original concept stipulated. Commercial trucking operations and fleets were not involved in the deployment, and experience gained in driver recruitment and training and vehicle installations of the MNA system represented less than 5% of original expectation. In emphasizing specific corridor and sub-area concepts rather than area-wide performance, due to deployment limitations, the project tests had a much-reduced ability to estimate the *overall* effectiveness of probes in conveying actual traffic conditions to a public information source. The project could not achieve the statistical reliability, attributable to the large accident and incident data base that could be potentially assembled under full deployment, of a comprehensive evaluation of MNA use by and distractions of drivers; thus, the findings of the more limited safety tests with recruited drivers soon to be released may not be as conclusive.

Also, the volume of data collected from the targeted deployment field tests, which would have been limited in any case, was further diminished by still-unaccounted-for losses in the transmission and archiving of electronically collected records. This problem impaired even some tests with relatively modest objectives.

However, test results might have been more conclusive overall had it not been discovered during testing that the benchmark against which travel time data was being evaluated — the network flow model's link traversal times — was itself impaired by large estimation errors, such that the far more reliable basis of comparison generated by every successive update of the static profile was actually developed during the testing phase itself and was thus unavailable until too late to serve as the testing platform. Until testing was completed, it was also unknown how important having data on signal timings in the arterial network would have been in estimating reliable formulas for travel time prediction and quantification of travel time relationships between through and turning movements at a given intersection.

Nevertheless, a subset of results of the *ADVANCE* evaluation would not change regardless of the scale of deployment:

- The user features of an in-route guidance system, such as those of the MNA units deployed for *ADVANCE*, must be able to accommodate a reasonably broad range of technological sophistication and network knowledge among the population likely to pay for and regularly use such a system and its associated services. Specifically, the capability should exist to “train” the

system to learn the user's preferred routes, then provide timely and relevant information about available time savings on alternative routes (especially those which may be "counter-intuitive" to a user familiar with the area road network).

- Users who regularly drive in a road network and know its normal traffic and congestion patterns tolerate recurrent time-of-day delays in the network on the links with which they are familiar and comfortable; thus, only a route guidance system capable of providing reliable real-time data about *non*-recurrent congestion is likely to find a market base beyond very specialized, very limited applications.
- Although real-time guidance on arterial networks can be provided, at significant public expense, in the absence of equipped vehicle probes, its quality and usefulness will be much diminished relative to what even a very limited deployment of probes could achieve.
- The quantity and timeliness of data flowing into a *properly functioning* traffic information center (that is, a center capable of fast and reliable message processing and turnaround) argues strongly that such a center will not achieve its full potential unless it is integrated directly with a traffic *management* center having the ability to intercede directly in modifying network flows.
- Route guidance algorithms that use probe data can be improved by including traffic signal timing data from the arterial system. The probe data itself significantly improves static (archival average) link travel time estimates by time of day.
- Automated incident detection algorithms for expressways do not yet possess sufficient reliability and transferability for stand-alone deployment. Probe- and detector-based incident detection on arterial networks show promise for improved performance and reliability.

Other less comprehensive findings of the *ADVANCE* experience and evaluation would be equally applicable to other deployments as "lessons learned" (see Section 6) but are not repeated here because they relate more directly to applied practice. In larger-scale deployments, project practices would have to be adjusted to accommodate different sets of needs and goals. Such adjustments may yield broader, perhaps more fundamental, discoveries about the limits, proper role, and driver acceptance of ATIS. However, on the basis of the project's seminal investigation of properties and performance of important ATIS concepts deployed in a limited yet focused manner, the evaluation manager for *ADVANCE* defends the position that most of the findings have wide-ranging implications and that present and future deployments cannot afford to ignore any of them.

10 THE LEGACY OF *ADVANCE*: THE GCM CORRIDOR AND BEYOND

Significant benefits resulted from the implementation and evaluation of *ADVANCE* as a targeted deployment. Probably the most important transferable benefit was gaining knowledge and experience of the operation of a real-time traffic information center sufficient to permit transition to full-scale transportation center operations for the Gary-Chicago-Milwaukee (GCM) tri-state corridor, obviating “shakedown” delays and setbacks that might otherwise have occurred. Progress in GCM corridor development is occurring faster than originally anticipated under a concept fully endorsed by responsible authorities in all affected states (Illinois, Indiana, Wisconsin) and is opening the tri-state region to opportunities for other public and private initiatives.

Obvious and significant fiscal savings resulted from the plan to use fewer test units over a shorter time span than originally envisioned. Compensating for the reduction in scope was a faster turnaround (just over a year) of analysis completion, report preparation, and availability of findings to the interested public than would have been possible with a two-year test. As discussed above, though testing was limited, some results are capable of broader generalization

In January of 1996, the *ADVANCE* TIC was decommissioned and in its place rose a Corridor Transportation Information Center (C-TIC), now providing real-time travel information to a broad multistate spectrum of interests. That is, the *ADVANCE* Corridor Transportation Information Center has expanded beyond the original *ADVANCE* test area to include expressways and major arterials in all three states throughout the GCM Corridor. The prototype center is operational. The practical architecture of the network of information sources feeding this center is now being demonstrated, and a full deployment scenario that will incorporate many features of an approved national infrastructure, including a standardized location referencing system and the National Transportation Communication and Information Protocol, is being reviewed as part of the GCM Multi-Modal Traveler Information System effort. Several information sources and media not used in *ADVANCE* will be a part of this multi-modal system; in fact, the only data source from the targeted deployment that will *not* be processed through the GCM C-TIC (at least in the near term) is GPS-based vehicle-locator probes.

The decision to adopt a targeted deployment approach for *ADVANCE* was a logical step in developing and advancing ITS technology. The dynamic route guidance concept that was central to *ADVANCE* was tested, the project infrastructure developed was enhanced to support a broader range of ITS deployments, and multistate corridor activities were supported and given a more central focus. The public and private participants in the project gained highly useful information from systems development and evaluation testing that has helped positively and productively to guide further ITS concept and product deployment pursuits.

APPENDIX A

ADVANCE

**Advanced Driver and Vehicle
Advisory Navigation Concept**

Traffic Related Functions
Evaluation Report (1 of 7)
Documents # 8460.00

CONTAINS:

- **Base Data and Static Profile Evaluation Report** -- Document # 8460-01.01
- Data Screening Evaluation Report** -- Document # 8460-02.02
- Quality of Probe Reports Evaluation Report** -- Document # 8460-03.01
- Travel Time Prediction and Performance of**
 - Probe and Detector Data Evaluation Report** -- Document # 8460-04.01
 - Detector Travel Time Conversion and Fusion of**
 - Probe and Detector Data Evaluation Report** -- Document # 8460-05.01
 - Frequency of Probe Reports Evaluation Report** -- Document # 8460-06.01
 - Relationships among Travel Times Evaluation Report** -- Document # 8460-07.02

Prepared by
University of Illinois-Chicago
Urban Transportation Center

DISCLAIMER

This report was prepared by a contractor for
Argonne National Laboratory
and is published as it was received.

ADVANCE Evaluation

Base Data and Static Profile

Ashish Sen, Helen Condie, Aaron Sheffey, Xin Tian
and Xiaoqun Zhu

URBAN TRANSPORTATION CENTER
University of Illinois at Chicago
1033 West Van Buren Street
Suite 700 South
Chicago, Illinois 60607

March 1996

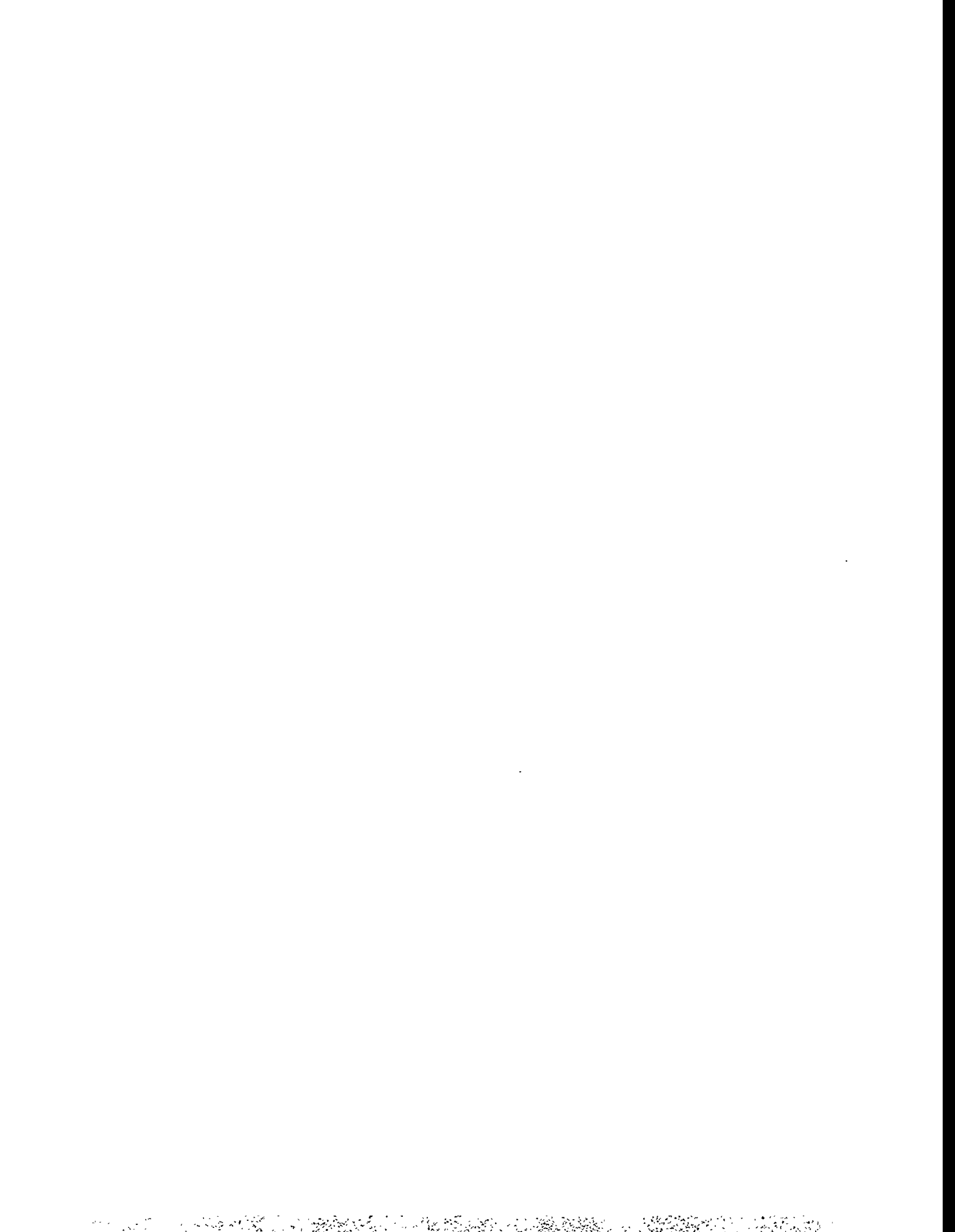

Executive Summary

For every link static profiles are default travel times used by the probe vehicle's MNA when dynamic travel-time estimates are not available. Dynamic estimates may not be available for two reasons: equipment failure, which is rather rare; and when dynamic estimates do not differ adequately from the static profiles and are therefore not broadcast. The latter situation is a property of the ADVANCE architecture and is based on the fact that dynamic estimates, based on very few observations, have large variances and unless they differ substantially from the static estimate, the static estimates are more reliable.

Since, when the demonstration started no probe data had been gathered, initial static profiles were constructed synthetically using an algorithm called the NFM algorithm. As data became available, the profiles were updated.

The purpose of the task reported on here is to evaluate the quality of the static profiles: both the initial profiles and their updated versions. For this purpose data were collected by probe vehicles for a 13-link network in the ADVANCE study area over a 12-week period. Static-Profile updating was performed every three weeks or so.

While the initial profiles did not reflect link travel times exceptionally accurately, this is understandable given that they were not based on any data that reflected link-specific conditions, either from probes or detectors. However, the updates substantially improved the quality of the estimates.

During the design stage of ADVANCE, each weekday was to be subdivided into 48 intervals for each of which the static profile would provide a single travel-time estimate for each ADVANCE link. However, during targeted deployment the number of intervals was reduced to 5 because not enough data would be gathered on most ADVANCE links to construct reliable updates. Since enough data were available for the links under study, both the 5-interval profiles and more detailed 10-interval profiles for 6-hour periods were examined. The profiles were evaluated in terms of their ability to match mean travel times and in terms of their efficacy as forecasts.

Overall, it was found that, especially after a few updates, static profiles were exceptionally accurate. The algorithms performed robustly against idiosyncratic probe-reported observations. Profiles based on probes only were found to be more accurate than those based on both probes and detectors.

Contents

| | |
|--|-----------|
| Executive Summary | i |
| 1 Introduction | 1 |
| 1.1 Background | 1 |
| 1.2 Data-Collection Schedule | 2 |
| 1.3 Study Area and Routes | 3 |
| 2 TRF Components Examined in this Report | 6 |
| 2.1 The BD Procedure | 7 |
| 2.2 SP Updating | 7 |
| 2.2.1 SPU: 2-Interval | 8 |
| 2.2.2 SPU: 10-Interval | 8 |
| 3 Data Collection and Analysis | 9 |
| 3.1 Data Collection | 9 |
| 3.2 Sample Size | 9 |
| 3.3 Data Analysis | 17 |
| 3.3.1 Data Sources | 17 |
| 3.3.2 SPU Runs | 17 |
| 4 Base Data - Results | 18 |
| 5 Static Profile Update - Results | 21 |
| 5.1 Updates 1, 2 and 3: 2-Interval Schedule | 21 |
| 5.1.1 Comparison of Travel Times with BD and Final SPUs | 24 |
| 5.1.2 Evaluation of SP and BD as Forecasts | 29 |
| 5.1.3 BD and SPU as Forecasts: Off-Peak Period | 30 |
| 5.1.4 BD and SPU as Forecasts: Peak Period | 30 |
| 5.1.5 Hypothesis Test | 39 |
| 5.2 Updates 4 and 5: 10-Interval Schedule | 40 |
| 5.2.1 Evaluation of SPU4 Estimates as Forecasts | 47 |
| 6 SPU Results - Fused Data | 49 |
| 6.1 2-Interval Schedule: Static Profile Updates 1, 2 and 3 | 49 |
| 6.2 10-Interval Schedule: Static Profile Updates 4 and 5 | 50 |
| 7 Conclusions. | 51 |
| References | 52 |
| Glossary | 53 |

List of Figures

| | | |
|----|---|----|
| 1 | Probe Data Collection: Long Route | 4 |
| 2 | Probe Data Collection: Short Route | 5 |
| 3 | Probe Data Collection: Turning Relationships Links | 6 |
| 4 | SP Updates: Time Periods and Interval Schedules | 18 |
| 5 | Average Travel Time (in seconds) by Number of Days, Links 1-6: Off-Peak | 25 |
| 6 | Average Travel Time (in seconds) by Number of Days, Links 7-12: Off-Peak | 26 |
| 7 | Average Travel Time (in seconds) by Number of Days, Links 1-6: Peak . . | 27 |
| 8 | Average Travel Time (in seconds) by Number of Days, Links 7-12: Peak . . | 28 |
| 9 | Difference between Average 5-minute Travel Time and BD Estimate (in seconds) by Number of 5-minute periods: Off-Peak | 32 |
| 10 | Difference between Average 5-minute Travel Time and SPU1 Estimate (in seconds) by Number of 5-minute periods: Off-Peak | 33 |
| 11 | Difference between Average 5-minute Travel Time and SPU2 Estimate (in seconds) by Number of 5-minute periods: Off-Peak | 34 |
| 12 | Difference between Average 5-minute Travel Time and BD Estimate (in seconds) by Number of 5-minute periods: Peak | 35 |
| 13 | Difference between Average 5-minute Travel Time and SPU1 Estimate (in seconds) by Number of 5-minute periods: Peak | 36 |
| 14 | Difference between Average 5-minute Travel Time and SPU2 Estimate (in seconds) by Number of 5-minute periods: Peak | 37 |
| 15 | Difference between Average 5-minute Travel Time and BD, SPU1 and SPU2 Estimates (in seconds) by Number of 5-minute periods: Links 10 and 11 | 38 |
| 16 | Alternative SP Update Time Periods and Interval Schedules | 41 |
| 17 | Average 5-minute Travel Time (in seconds) by Number of 5-minute periods, Links 2, 10 and 11: SPU4 | 48 |

List of Tables

| | | |
|----|--|----|
| 1 | Probe Reports for each Hour of Data Collection | 3 |
| 2 | MNA Reports by Link | 5 |
| 3 | 10-Interval Schedule (Graves) | 9 |
| 4 | Static Profile Updates: Time Periods | 10 |
| 5 | Number of Probe Reports, 2-Interval Schedule: 1:00-4:00pm | 11 |
| 6 | Number of Probe Reports, 2-Interval Schedule: 4:00-6:00pm | 11 |
| 7 | Number of Probe Reports, 10-Interval Schedule: 1:00-2:30pm | 12 |
| 8 | Number of Probe Reports, 10-Interval Schedule: 2:30-3:10pm | 12 |
| 9 | Number of Probe Reports, 10-Interval Schedule: 3:10-4:00pm | 13 |
| 10 | Number of Probe Reports, 10-Interval Schedule: 4:00-4:40pm | 13 |

| | | |
|----|--|----|
| 11 | Number of Probe Reports, 10-Interval Schedule: 4:40-5:10pm | 14 |
| 12 | Number of Probe Reports, 10-Interval Schedule: 5:10-5:30pm | 14 |
| 13 | Number of Probe Reports, 10-Interval Schedule: 5:30-5:40pm | 15 |
| 14 | Number of Probe Reports, 10-Interval Schedule: 5:40-6:00pm | 15 |
| 15 | Number of Probe Reports, 10-Interval Schedule: 6:00-6:45pm | 16 |
| 16 | Number of Probe Reports, 10-Interval Schedule: 6:45-7:00pm | 16 |
| 17 | Base Data Travel Time Estimates (in seconds), 2-Interval Schedule: Off-Peak | 19 |
| 18 | Base Data Travel Time Estimates (in seconds), 2-Interval Schedule: Peak . | 19 |
| 19 | Detector Volumes and NFM Estimates: Off-Peak | 20 |
| 20 | Detector Volumes and NFM Estimates: Peak | 21 |
| 21 | Static Profile Travel Time Estimates (in seconds), 2-Interval Schedule: Off- Peak | 22 |
| 22 | Static Profile Travel Time Estimates (in seconds), 2-Interval Schedule: Peak | 23 |
| 23 | SPU3 Travel Time Estimates (in seconds) Compared to Probe Travel Times: Off-Peak | 39 |
| 24 | SPU3 Travel Time Estimates (in seconds) Compared to Probe Travel Times: Peak | 40 |
| 25 | Static Profile Travel Time Estimates (in seconds), 10-Interval Schedule: 1:00-2:30 pm | 42 |
| 26 | Static Profile Travel Time Estimates (in seconds), 10-Interval Schedule: 2:30-3:10 pm | 43 |
| 27 | Static Profile Travel Time Estimates (in seconds), 10-Interval Schedule: 3:10-4:00 pm | 43 |
| 28 | Static Profile Travel Time Estimates (in seconds), 10-Interval Schedule: 4:00-4:40 pm | 44 |
| 29 | Static Profile Travel Time Estimates (in seconds), 10-Interval Schedule: 4:40-5:10 pm | 44 |
| 30 | Static Profile Travel Time Estimates (in seconds), 10-Interval Schedule: 5:10-5:30 pm | 45 |
| 31 | Static Profile Travel Time Estimates (in seconds), 10-Interval Schedule: 5:30-5:40 pm | 45 |
| 32 | Static Profile Travel Time Estimates (in seconds), 10-Interval Schedule: 5:40-6:00 pm | 46 |
| 33 | Static Profile Travel Time Estimates (in seconds), 10-Interval Schedule: 6:00-6:45 pm | 46 |
| 34 | Static Profile Travel Time Estimates (in seconds), 10-Interval Schedule: 6:45-7:00 pm | 47 |
| 35 | SPU 1 Travel Time Estimates (in seconds) for Links 1, 7 and 11 using Fused Data | 49 |
| 36 | SPU 2 Travel Time Estimates (in seconds) for Links 1, 7 and 11 using Fused Data | 49 |

| | | |
|----|---|----|
| 37 | SPU 3 Travel Time Estimates (in seconds) for Links 1, 7 and 11 using Fused Data | 50 |
| 38 | SPU 4 Travel Time Estimates (in seconds) for Links 1, 7 and 11 using Fused Data | 50 |
| 39 | SPU 5 Travel Time Estimates (in seconds) for Links 1, 7 and 11 using Fused Data | 51 |

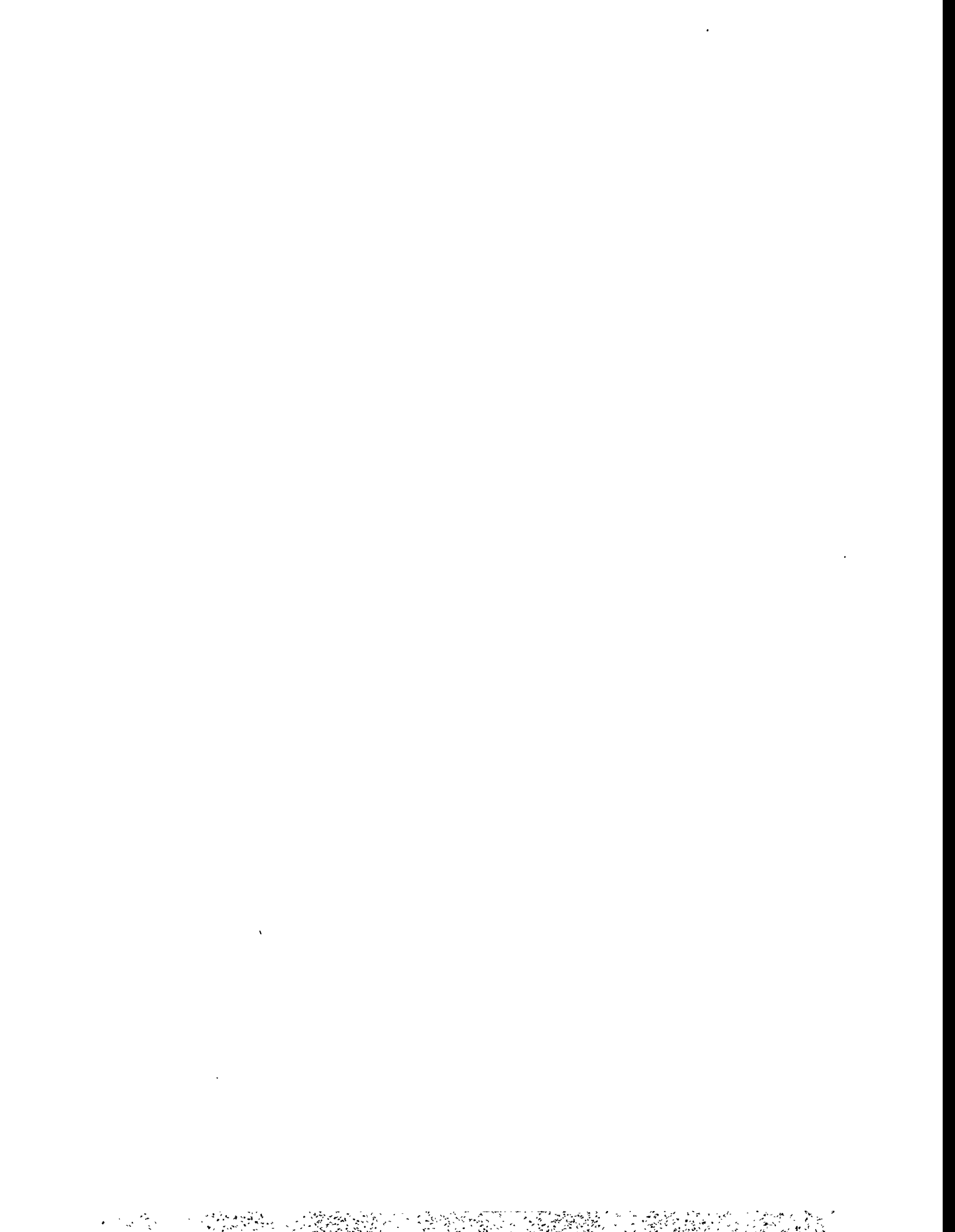

1 Introduction

1.1 Background

In the ADVANCE system, the Mobile Navigation Assistant (MNA) in equipped vehicles computes desirable routes based on predicted travel times. Some of these estimated travel times are obtained via radio from a central computer, called the Traffic Information Center (TIC). The MNA receives broadcasts only when the car ignition is turned on. Few drivers would be willing to wait very long to get route guidance after they have entered the car; on the other hand, there are over 10,000 links in the system and the radio frequencies (RF) available have modest capacities. Thus, it is impossible to broadcast information on all links and have it available for the initial guidance given to the driver. Consequently, default travel time predictions need to be available to the MNA. These defaults would be overwritten by real-time estimates of travel time (available via RF communication) when these real-time or *dynamic* estimates differ significantly from the default estimates. Moreover, the default estimates would also be available in case transmissions are interrupted.

These default travel times, based on historical and other information, reside on a compact disk in the MNA and are called Static Profiles (SP). They are also contained within a corpus termed the Static Profile Database (SPD). Initial profiles were constructed using the Network Flow Model (NFM) and are contained in the Base Data (BD) component of Traffic Related Functions (TRF). After enough data have been collected from probes, the NFM estimates (BD) are revised using a procedure called Static Profile Updating (SPU). As more data are collected further revisions occur using a slightly different version of the SPU procedure.

The Base Data and Static Profile process may be summarized as:

1. initial travel time profiles constructed using the Network Flow Model, stored as Base Data,
2. travel time data collected from probes,
3. Network Flow Model estimates of travel times revised using a procedure called Static Profile Updating (SPU), the products of these updates being called Static Profiles (SP); and,
4. further data collection and revisions of SP, using the Static Profile Updating procedure.

During the summer of 1995 an average of twelve vehicles were driven four days a week over an eleven-week period. During this time almost 60,000 miles were driven to produce over 50,000 link reports within a confined study area. While these reports have been and will be used for several purposes, they also provide the travel-time data required to perform static profile updates.

The purpose of the BD/SP task is to assess the quality of the Base Data estimated by the Network Flow Model (NFM) and the quality of the static profiles (SP) estimated by the SP update algorithm. The validation of the NFM will be based on data from a representative sample of links by comparing probe data to outputs from the NFM. Similarly, the validation of the static profiles will be based on a representative sample of links by comparing probe data to static profile data.

The aim of the base data and static profile evaluation task is therefore to assess the quality of the initial NFM estimates and the results of several updates of these estimates. The procedures followed for both data collection and analysis are taken directly from the Evaluation Test Plan (ETP) for BD/SP. For convenience we call the NFM estimates BD estimates and reserve the name SP for results of updates. The ETP states that this task will test two hypotheses. The first hypothesis is that the NFM consistently and accurately estimates travel times. The second hypothesis is that the SP consistently and accurately estimates travel times.

Since the whole purpose of the BD and SP estimates is to reflect average travel times, most comparisons made below are with such averages computed from travel times reported by probes.

We used data gathered during the summer of 1995, from 1pm to shortly after 7pm, Monday through Thursday for a 12-week period. Our overall assessment of the SPU algorithm as applied to this data is that in the version of TRF that has been implemented, the static profile estimates on nearly all links are very accurate once a reasonable amount of probe data becomes available. This is reflected in the increasing accuracy of SP runs as more probe data becomes available. We can make the conjecture that the SPU algorithm would work equally well with data from all day types and time periods.

Although we have noted possibilities for improvement, these are confined to subcomponents. While these deficiencies should be addressed in future implementations, the overall performance of the system as implemented is more than acceptable.

1.2 Data-Collection Schedule

Data were collected on several study routes Monday through Thursday from June 5th to August 10th. At the beginning of each day of data collection, a twelve-noon briefing was held at the ADVANCE office in Schaumburg. At this time the drivers were assigned vehicles and they left the office at approximately 12:30pm. Each driver used a designated route to drive to the study area. There were several different routes; this report is not concerned with the routes to and from the study area. Data were collected by probe vehicles driven in the study area between 1pm and 7pm (Table 1), with breaks as described below.

On each day of data collection a field manager was present at the staging area. The field manager ensured that vehicles were driving the study route at satisfactory headways and instructed drivers when to take breaks. An effort was made to release the probe vehicles at random intervals but variations in probe travel times caused some deviation

Table 1: Probe Reports for each Hour of Data Collection

| Hour Beginning | No of Reports | Percent of Total |
|----------------|---------------|------------------|
| 1pm | 8464 | 16.7 |
| 2pm | 7980 | 15.8 |
| 3pm | 5187 | 10.2 |
| 4pm | 8488 | 16.8 |
| 5pm | 8433 | 16.7 |
| 6pm | 7871 | 15.5 |
| 7pm | 4197 | 8.3 |
| Total | 50620 | 100.0 |

from the schemes developed to achieve random release. The field manager also assisted with MNA failures and other problems.

The drivers were given a ten-minute break at approximately 2:00pm and another one from approximately 6:00pm to 6:10pm. Each driver took his or her break at a slightly different time, since each was dispatched by the field manager to the break area as they arrived at the staging area. During breaks each probe vehicle was inactive for more than ten minutes as time was lost off-route and also because the vehicle and MNA needed warm-up time. A longer break occurred from 3:30pm to 4:00pm. After this break, during the two-hour peak period from 4:00pm to 6:00pm, the drivers operated their vehicles without scheduled breaks.

1.3 Study Area and Routes

The entire routes driven on Dundee Road and adjacent arterials were within the municipality of Wheeling, Illinois (north suburban Chicago). Dundee Road was selected because it carries a high volume of traffic and because each signalized intersection is demand actuated by loop detectors (including turning lanes) and there are volume and occupancy detectors in several locations. Although Dundee Road extends for several miles within the ADVANCE study area the number of potential places along Dundee Road where the necessary field tests could be performed was very limited. The data-collection route required a convenient location where vehicles could turn around safely and avoid being off the study route for a long period of time. For a number of the evaluation tasks (although not BD/SP, the subject of this report) the route also needed a mix of link and intersection characteristics.

Two route configurations were used for the field data collection. The first route (Figure 1) is the long route and was used for the majority of TRF evaluations, including the subject of this report. The long route consists of twelve links. The section of the route on Schoenbeck Road and Palm Drive (near the west end) was used as a staging and

turnaround area and since it was too short to complete a recognized link, data were not collected for this section of the route. The route was selected to be completed during a fifteen-minute period to achieve the density of coverage desired for most tests. During the off-peak period the majority of the drivers completed this twelve-link route in ten to fourteen minutes.

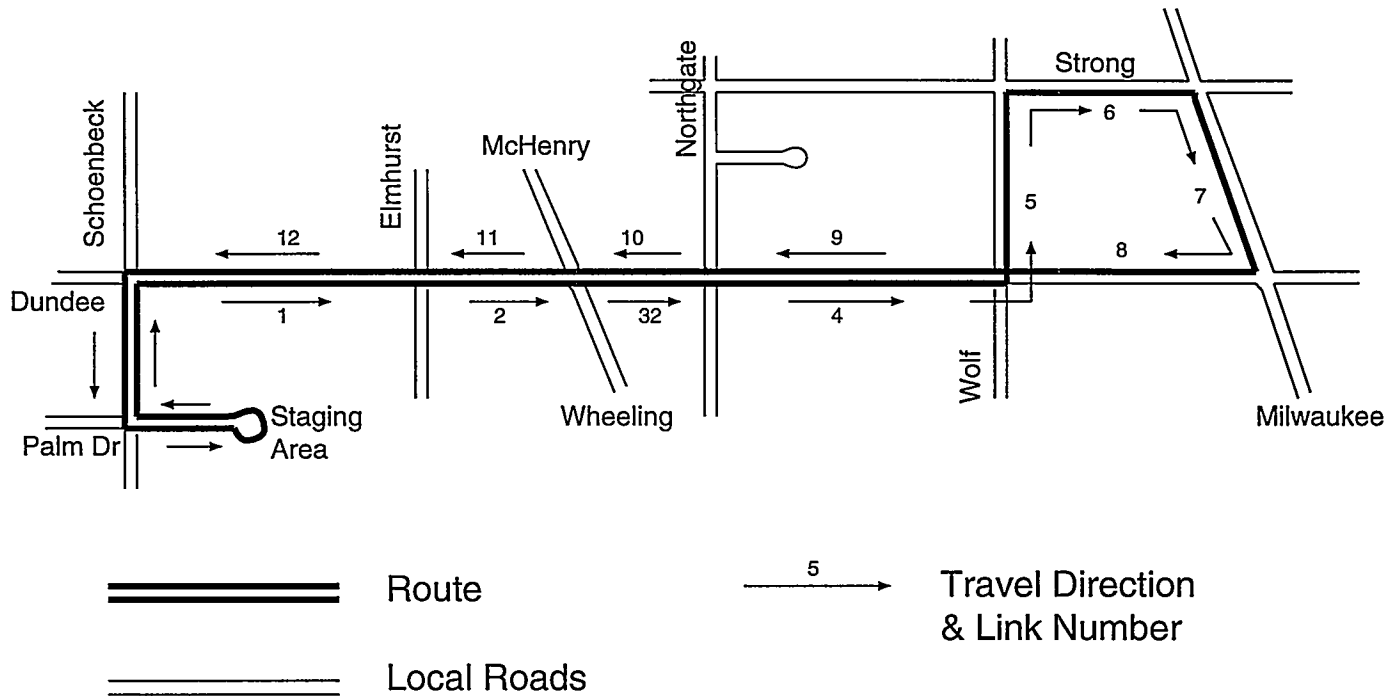

Figure 1: Probe Data Collection: Long Route

During the peak period this route proved to be too long to complete in fifteen minutes and on certain days a shorter alternative was used. This route is shown in Figure 2. Even the short route could not always be completed in fifteen minutes but this happened infrequently.

Using two different data collection routes resulted in variation in the numbers of probe reports from each link (i.e., the links solely on the long route are traversed less frequently). For the evaluation of static profiles, variation in the number of probe reports from each link is of value as it allows the exercise of the SP procedure for different frequencies of probe deployment.

Links 4 through 9 are on the long route but do not have the same number of link reports for two reasons (Table 2). First, many of the breaks were taken on this portion of the route. The most common break location was on Link 8 and there are correspondingly fewer reports on this link (the vehicles need to travel the entire link without stopping to create a report). Second, there may have been MNA failures and other reasons for turning off the link and stopping.

During the last three weeks of data collection in the Dundee Road study area the

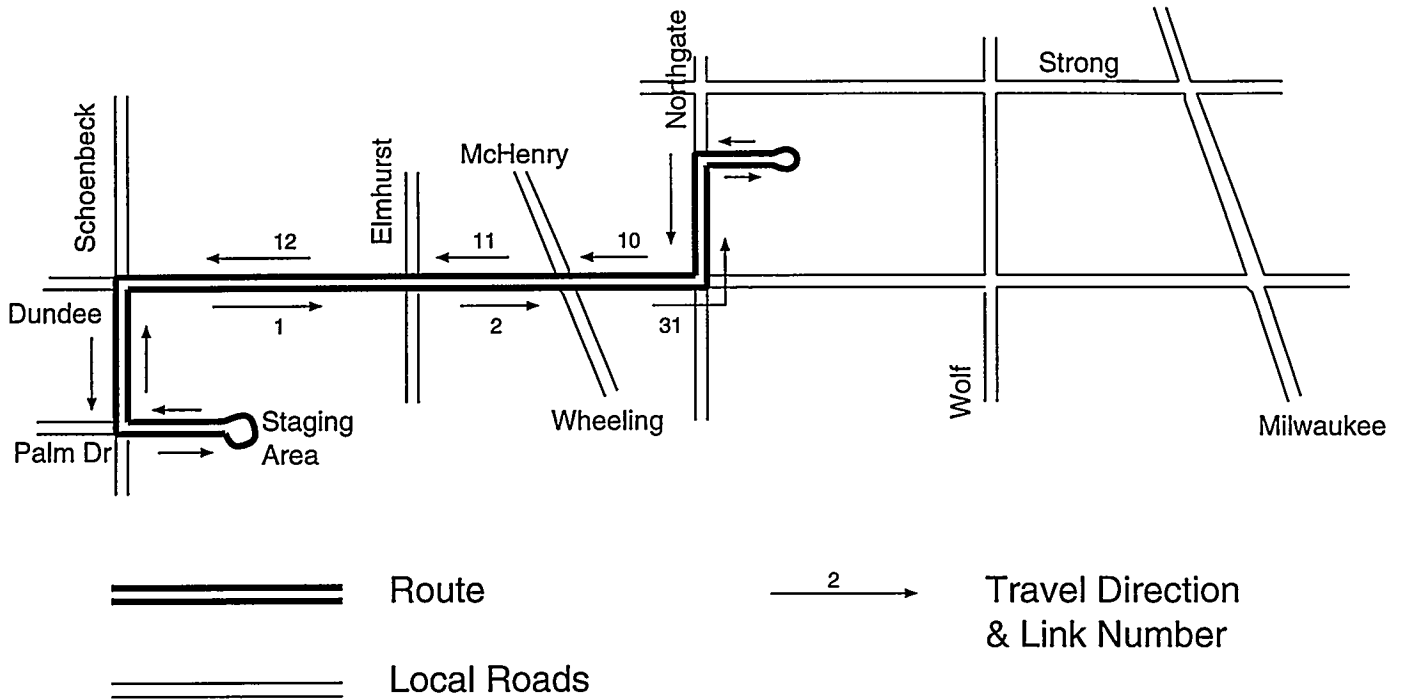

Figure 2: Probe Data Collection: Short Route

Table 2: MNA Reports by Link

| Link | Frequency | Percent | Link | Frequency | Percent |
|------|-----------|---------|-------|-----------|---------|
| 1 | 5481 | 9.7 | 7 | 2323 | 4.1 |
| 2 | 6298 | 11.1 | 8 | 2172 | 3.8 |
| 3* | 5886 | 10.4 * | 9 | 2462 | 4.3 |
| 4 | 2313 | 4.1 | 10 | 6066 | 10.7 |
| 5 | 2294 | 4.1 | 11 | 7826 | 13.8 |
| 6 | 2293 | 4.0 | 12 | 5206 | 9.2 |
| 31* | 3555 | 6.3 * | | | |
| 32* | 2331 | 4.1 * | | | |
| | | | Total | 50,620 | 100.0 |

* Link 3 consists of two links, 31 and 32. Link 31 is on the short route and includes a left turn at the end of the link. Link 32 is on the long route and has a through movement at the end of the link (no turn)

vehicles were being used to evaluate turning movement travel time predictions. In this case each driver was given a set of randomly drawn routes, to be driven in sequence, which covered the links shown on Figure 3. This consisted of fourteen uni-directional links. On Link H/h the drivers were permitted to stop and study the rest of the routes they had been assigned to drive. Data collection on the turning relationships route generally yielded more than 1500 usable MNA reports per day. Over half of these reports are on Dundee Road (links A, a, B, b, E and e) and are used in deriving static profiles. The Dundee Road links are identified on Figure 3. Several of the links on the long route are traversed infrequently during this period. Again, the resultant variation in probe density on the study links is welcome for the purpose of this evaluation.

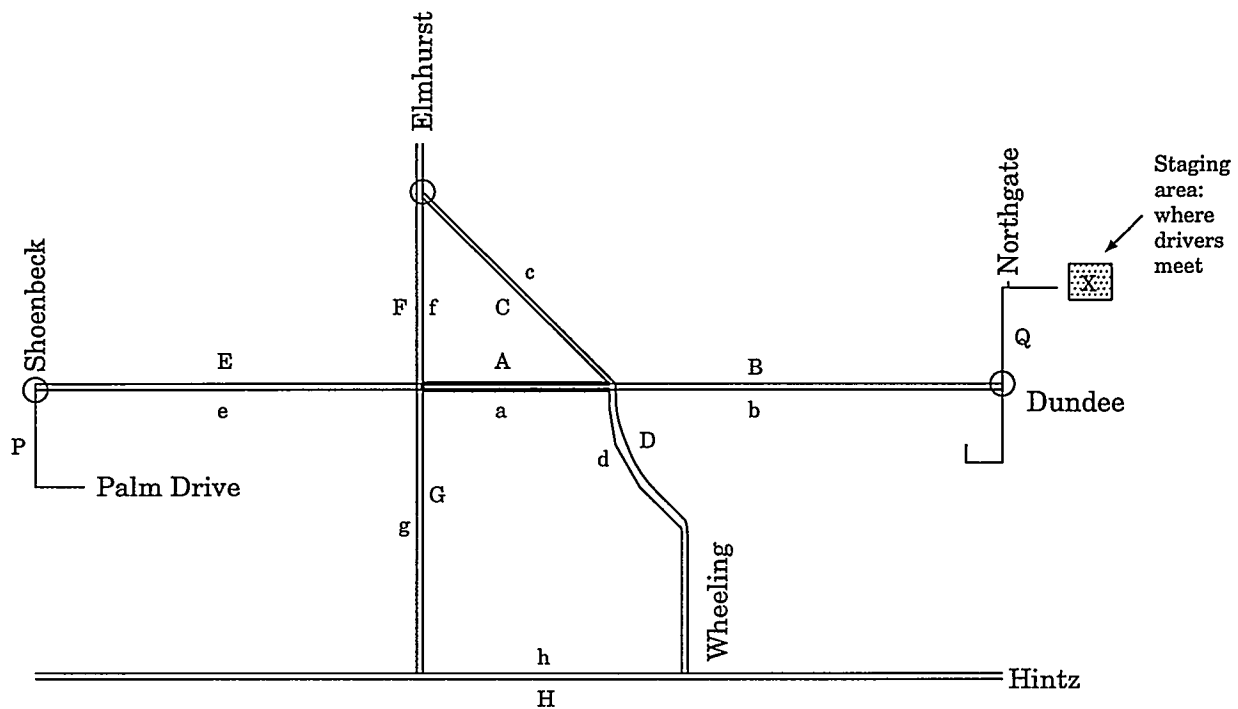

Dundee Road Links:

| | | |
|-------------------|-------------------|-------------------|
| Link EP = Link 12 | Link AE = Link 11 | Link BA = Link 10 |
| Link ea = Link 1 | Link ab = Link 2 | Link bQ = Link 31 |

Figure 3: Probe Data Collection: Turning Relationships Links

2 TRF Components Examined in this Report

In this section we outline the TRF components that are evaluated in this report. This presentation is made in order to make the report more self-contained. For details of the procedures, we refer the reader to Berka et al., 1994 and ADVANCE Working Paper No. 41 for the BD procedure and to ADVANCE Working Paper No. 49 for SPU.

2.1 The BD Procedure

Since before probe deployment occurred travel-time estimates could not be obtained from probe data, initial estimates of travel times needed to be synthesized by means of a model which used only readily available information. BD travel time estimates were therefore generated by means of a model called the Network Flow Model (NFM). Models of the NFM type are network equilibrium models and are based on the principle that every traveler minimizes his/her travel time (or some more general travel cost, a major component of which would be travel time). The total number of vehicles (OD volumes) between every origin and every destination, and a set of cost functions which describes the relation between volumes and travel times on every link are entered into the model. In this case, the NFM used cost functions which were realistic traffic engineering functions to create the BD estimates. The Chicago Area Transportation Study (CATS) provided 1990 OD volume estimates.

In the NFM used to construct the BD estimates, each weekday was divided into 5 intervals: 0000 - 0600; 0600 - 0900; 0900 - 1600; 1600 - 1800; and, 1800 - 2400. However, the CATS data provided a total demand volume for the whole day. To overcome this problem, the CATS 24-hour demand volumes were factored into volumes for specific time intervals (see ADVANCE Working Paper No. 43).

Only two of the BD intervals substantially intersect the time period over which data were collected (1pm - 7pm) and our evaluation is based on these. That is, our evaluation of BD is for the period 1-4pm (the off-peak period), and for 4-6pm (the peak period).

2.2 SP Updating

When probe data became available, SPU algorithms updated BD estimates. The basic method of updating is a straightforward Bayes' procedure described in ADVANCE Working Paper No. 49. However, some additional safe-guards have also been designed. The aim of one of these was to detect major shifts in average travel times for two consecutive updating intervals, to warn the operator of this and to take other appropriate actions. This particular safe-guard was not implemented for the targeted deployment.

As designed, each weekday was to consist of 2 day types (Monday to Thursday AM and Monday to Thursday PM). Each day type would have had 24 SP intervals. When the decision was made to move from full deployment (of many thousands of probe vehicles in a large study area) to targeted deployment we moved to the 5 BD intervals. This was because, for the entire study area of full deployment, not enough data would be gathered by a small number of probe vehicles. However the targeted deployment of a small number of vehicles on a small number of links (on the study route) simulated the probe coverage of full deployment in terms of the number and frequency of probe reports per link. We are therefore in a position where we could evaluate the SP/BD procedure both *as designed* (for full deployment) and *as implemented*.

No decision had been taken as to how frequently SP updating was to occur under

full deployment (full deployment is described in the following section). However, there seemed to be a general assumption that updating was to be carried out every 2 to 3 months. Since the data gathering for the TRF evaluation was for a twelve-week period and we wished to carry out several updates, for the purpose of this evaluation we used much shorter updating time periods as indicated below.

Static profile updates were designed to be step functions; that is, the day was assumed to be divided into several intervals over each of which the SP would have a single value. We shall call these intervals, which could be several minutes (or several hours) long, *SP intervals* to distinguish them from the *updating intervals* (which would be several days or weeks long) just mentioned.

2.2.1 SPU: 2-Interval

We constructed SPU estimates for two of the 5 BD intervals (1-4pm and 4-6pm) that substantially overlapped our data gathering period. We compared these estimates to mean travel times. We call this evaluation the evaluation of SP *as implemented*, or the evaluation of the *2-interval SPU*. The results of the SP updating procedure using the 2-interval schedule are presented in Section 5.1 of this report.

2.2.2 SPU: 10-Interval

We also constructed a larger number of SP intervals and evaluated SPU estimates for these. We call this an evaluation of SPU *as designed* or the evaluation of the *10-interval SPU*.

The intervals had not been defined in the SP design, the idea being that the most suitable intervals would only become apparent after some link travel time data were available. Therefore, we needed to obtain suitable intervals. The intervals that were used in the evaluation were constructed using an ANOVA-based procedure. We are indebted to Todd Graves of the National Institute of Statistical Sciences for his help in constructing suitable intervals. These SP intervals were those over which travel times on links under study were relatively constant.

The number of intervals for the SPU *as designed* evaluation was not predetermined; the statistical method used by Todd Graves identified the optimum number of intervals. Ten satisfactory intervals emerged from this procedure.

As designed there were to be 24 intervals per day type; Monday - Thursday AM and Monday - Thursday PM are two of the day types. Therefore, for our 6-hour data collection period 10 intervals looks about right. Note that we are working with short updating time periods, so that data shortage (i.e., a very small number of probe reports during the time period for the interval) is a possibility. See, for example, Tables 12 to 14. When conducting the evaluation for 10 intervals, the first update was for only 2 intervals. During the second update the number of intervals was expanded to 10. Table 3 gives the 10-interval schedule. The results of the SP updating procedure using the 10-interval

Table 3: 10-Interval Schedule (Graves)

| Interval Number | Time Period | Interval Number | Time Period |
|-----------------|--------------|-----------------|--------------|
| 1 | 1:00-2:30 pm | 6 | 5:10-5:30 pm |
| 2 | 2:30-3:10 pm | 7 | 5:30-5:40 pm |
| 3 | 3:10-4:00 pm | 8 | 5:40-6:00 pm |
| 4 | 4:00-4:40 pm | 9 | 6:00-6:45 pm |
| 5 | 4:40-5:10 pm | 10 | 6:45-7:00 pm |

schedule are presented in Section 5.2 of this report.

3 Data Collection and Analysis

3.1 Data Collection

In the initial design of the ADVANCE project, several thousand cars were to be deployed over 10,000 links. These large volumes were proposed in order to provide enough data to perform various TRF tasks. Instead of this large design, a *targeted deployment* using fewer cars per day over a smaller number of links was implemented. In the data collection exercise for TRF evaluations between 8 and 15 cars per day were driven over a small number of links in order to simulate, on these links, probe frequencies that would have occurred under full probe deployment.

The data used to perform SP updates were gathered over the period June 6–August 4, 1995. Data collection was divided into three collection periods for SPU purposes: June 6–June 18, June 19–July 9, and July 10–August 4. Updates were made corresponding to the last day of each collection period (i.e., June 18, July 9 and August 4).

All analyses were performed off-line after data collection was complete. Table 4 shows the periods over which data were gathered for each updating exercise. SPU_x refers to specific runs of the SPU procedure, and the results of these updates are referred to as SP_x or Static Profile x .

Static Profile Updates 2 and 4 are both derived using probe data collected during the time period June 19–July 09; Static Profile Updates 3 and 5 are both derived using probe data collected during the time period July 10–August 04. Static Profile Updates 1, 2 and 3 use a 2-interval schedule; Static Profile Updates 4 and 5 use the 10-interval schedule.

3.2 Sample Size

The numbers of probe reports received from each link for each interval in the 2-interval schedule are given in Tables 5 and 6. The tables also show the sample means, sample

Table 4: Static Profile Updates: Time Periods

| Dates | 2-Interval | 10-interval |
|------------------|------------|-------------|
| June 6–June 18 | SPU 1 | |
| June 19–July 9 | SPU 2 | SPU 4 |
| July 10–August 4 | SPU 3 | SPU 5 |

standard deviations (S.D) and sample standard errors (S.E.). It is very important to note that these quantities were computed formally using formulae contained in the statistical package SAS. These formulae are derived assuming observations are uncorrelated. Since a car following another car would have link travel times very similar to the car in front, and also because two cars arriving at an intersection at the same time after a signal has turned red would have similar travel times, even if they arrived in different cycles, probe travel times are not uncorrelated. Therefore, while the formula for the sample mean is not affected by this correlation between travel times and the standard deviation is only marginally affected, the expression for the standard error of the mean is substantially affected — the true values of the standard error might be several times larger than the numbers given in the table. Unfortunately a correct computation of standard error requires estimates of covariances which are not currently available.

The numbers of probe reports received from each link for each interval in the 10-interval schedule are given in Tables 7 to 16. The discussion on correlation between travel times given above applies equally to the values for the standard error given in these tables.

The numbers of probe reports given in these tables do not correspond exactly with the numbers in Tables 1 and 2 in Section 1. The numbers in Tables 1 and 2 relate to the entire eleven-week data collection period for all TRF evaluations, while the numbers in Tables 5 to 16 relate only to data collected during the period from June 6 to August 4, from 1pm to 7pm, which is used for SP updating.

In tables 5 to 16:

Number = number of probe reports in the sample

Mean = mean link travel time for the sample

S.D = standard deviation of the sample travel time

S.E. = standard error of the sample travel time

Table 5: Number of Probe Reports, 2-Interval Schedule: 1:00-4:00pm

| Link | Number | Mean | S.D. | S.E. |
|------|--------|---------|--------|-------|
| 1 | 2032 | 75.629 | 22.542 | 0.500 |
| 2 | 2085 | 43.829 | 28.693 | 0.628 |
| 31 | 940 | 62.838 | 31.268 | 1.020 |
| 32 | 1185 | 30.271 | 16.212 | 0.471 |
| 4 | 1189 | 95.423 | 33.064 | 0.959 |
| 5 | 1163 | 36.536 | 4.060 | 0.119 |
| 6 | 1164 | 45.304 | 9.747 | 0.286 |
| 7 | 1171 | 107.403 | 51.980 | 1.519 |
| 8 | 1025 | 55.633 | 21.228 | 0.663 |
| 9 | 1125 | 64.017 | 30.505 | 0.909 |
| 10 | 2023 | 60.255 | 30.408 | 0.676 |
| 11 | 1833 | 56.585 | 28.423 | 0.644 |
| 12 | 1822 | 74.869 | 22.522 | 0.528 |

Table 6: Number of Probe Reports, 2-Interval Schedule: 4:00-6:00pm

| Link | Number | Mean | S.D. | S.E. |
|------|--------|---------|---------|-------|
| 1 | 1793 | 70.843 | 24.172 | 0.571 |
| 2 | 1771 | 58.754 | 33.055 | 0.785 |
| 31 | 1307 | 66.516 | 32.168 | 0.890 |
| 32 | 551 | 41.548 | 19.624 | 0.836 |
| 4 | 558 | 119.057 | 47.059 | 1.992 |
| 5 | 555 | 37.978 | 7.528 | 0.320 |
| 6 | 548 | 56.801 | 26.643 | 1.138 |
| 7 | 500 | 225.366 | 120.821 | 5.403 |
| 8 | 580 | 104.586 | 73.363 | 3.046 |
| 9 | 613 | 198.796 | 106.922 | 4.319 |
| 10 | 1949 | 82.177 | 23.593 | 0.534 |
| 11 | 1830 | 52.713 | 27.810 | 0.650 |
| 12 | 1801 | 85.878 | 33.677 | 0.794 |

Table 7: Number of Probe Reports, 10-Interval Schedule: 1:00-2:30pm

| Link | Number | Mean | S.D. | S.E. |
|------|--------|--------|--------|-------|
| 1 | 1194 | 75.742 | 21.183 | 0.613 |
| 2 | 1230 | 42.946 | 27.305 | 0.779 |
| 31 | 538 | 58.874 | 32.079 | 1.383 |
| 32 | 705 | 30.672 | 16.696 | 0.629 |
| 4 | 699 | 91.956 | 30.977 | 1.172 |
| 5 | 699 | 36.546 | 3.747 | 0.142 |
| 6 | 698 | 45.274 | 10.317 | 0.391 |
| 7 | 705 | 98.410 | 39.973 | 1.505 |
| 8 | 612 | 54.317 | 22.767 | 0.920 |
| 9 | 625 | 58.392 | 17.501 | 0.700 |
| 10 | 1080 | 53.985 | 28.976 | 0.882 |
| 11 | 974 | 57.727 | 27.714 | 0.888 |
| 12 | 974 | 74.340 | 19.634 | 0.629 |

Table 8: Number of Probe Reports, 10-Interval Schedule: 2:30-3:10pm

| Link | Number | Mean | S.D. | S.E. |
|------|--------|---------|--------|-------|
| 1 | 521 | 74.240 | 22.207 | 0.973 |
| 2 | 510 | 43.373 | 27.747 | 1.229 |
| 31 | 243 | 65.626 | 30.422 | 1.952 |
| 32 | 284 | 28.930 | 14.196 | 0.842 |
| 4 | 288 | 99.972 | 35.553 | 2.095 |
| 5 | 293 | 36.369 | 3.439 | 0.201 |
| 6 | 274 | 45.526 | 8.246 | 0.498 |
| 7 | 274 | 109.365 | 58.128 | 3.512 |
| 8 | 251 | 55.426 | 16.752 | 1.057 |
| 9 | 343 | 62.656 | 24.580 | 1.327 |
| 10 | 623 | 61.136 | 29.191 | 1.169 |
| 11 | 570 | 52.300 | 26.736 | 1.120 |
| 12 | 551 | 74.564 | 24.650 | 1.050 |

Table 9: Number of Probe Reports, 10-Interval Schedule: 3:10-4:00pm

| Link | Number | Mean | S.D. | S.E. |
|------|--------|---------|--------|-------|
| 1 | 317 | 77.489 | 27.452 | 1.542 |
| 2 | 345 | 47.655 | 34.162 | 1.839 |
| 31 | 159 | 71.994 | 27.307 | 2.166 |
| 32 | 196 | 30.770 | 17.132 | 1.224 |
| 4 | 202 | 100.936 | 34.960 | 2.460 |
| 5 | 171 | 36.778 | 5.884 | 0.450 |
| 6 | 192 | 45.099 | 9.629 | 0.695 |
| 7 | 192 | 137.625 | 67.896 | 4.900 |
| 8 | 162 | 60.926 | 20.699 | 1.626 |
| 9 | 157 | 89.382 | 58.110 | 4.638 |
| 10 | 320 | 79.697 | 29.083 | 1.626 |
| 11 | 289 | 61.190 | 32.710 | 1.924 |
| 12 | 297 | 77.172 | 26.797 | 1.555 |

Table 10: Number of Probe Reports, 10-Interval Schedule: 4:00-4:40pm

| Link | Number | Mean | S.D. | S.E. |
|------|--------|---------|--------|-------|
| 1 | 530 | 73.251 | 26.939 | 1.170 |
| 2 | 536 | 57.799 | 29.282 | 1.265 |
| 31 | 374 | 68.198 | 31.447 | 1.626 |
| 32 | 184 | 41.473 | 19.338 | 1.426 |
| 4 | 190 | 122.384 | 47.855 | 3.472 |
| 5 | 186 | 37.747 | 5.385 | 0.395 |
| 6 | 191 | 48.801 | 14.666 | 1.061 |
| 7 | 188 | 166.851 | 89.004 | 6.491 |
| 8 | 203 | 90.892 | 47.099 | 3.306 |
| 9 | 228 | 162.079 | 93.124 | 6.167 |
| 10 | 596 | 78.044 | 25.166 | 1.031 |
| 11 | 571 | 52.217 | 27.064 | 1.133 |
| 12 | 573 | 80.679 | 25.539 | 1.067 |

Table 11: Number of Probe Reports, 10-Interval Schedule: 4:40-5:10pm

| Link | Number | Mean | S.D. | S.E. |
|------|--------|---------|---------|-------|
| 1 | 494 | 71.004 | 23.443 | 1.055 |
| 2 | 475 | 59.956 | 42.538 | 1.952 |
| 31 | 354 | 65.602 | 31.270 | 1.662 |
| 32 | 141 | 40.979 | 18.385 | 1.548 |
| 4 | 148 | 112.108 | 43.502 | 3.576 |
| 5 | 153 | 37.078 | 4.375 | 0.354 |
| 6 | 146 | 49.795 | 14.511 | 1.201 |
| 7 | 133 | 187.323 | 75.881 | 6.580 |
| 8 | 143 | 98.811 | 70.535 | 5.898 |
| 9 | 148 | 187.128 | 117.610 | 9.667 |
| 10 | 518 | 83.718 | 23.793 | 1.045 |
| 11 | 487 | 51.450 | 27.854 | 1.262 |
| 12 | 482 | 88.618 | 48.856 | 2.225 |

Table 12: Number of Probe Reports, 10-Interval Schedule: 5:10-5:30pm

| Link | Number | Mean | S.D. | S.E. |
|------|--------|---------|---------|--------|
| 1 | 294 | 69.415 | 21.942 | 1.280 |
| 2 | 300 | 59.430 | 29.795 | 1.720 |
| 31 | 231 | 64.675 | 32.110 | 2.113 |
| 32 | 87 | 43.115 | 18.178 | 1.949 |
| 4 | 85 | 119.988 | 46.381 | 5.031 |
| 5 | 86 | 39.779 | 11.720 | 1.264 |
| 6 | 78 | 68.808 | 26.477 | 2.998 |
| 7 | 75 | 309.693 | 94.005 | 10.855 |
| 8 | 87 | 137.230 | 110.817 | 11.881 |
| 9 | 88 | 266.977 | 101.417 | 10.811 |
| 10 | 327 | 85.352 | 21.700 | 1.200 |
| 11 | 298 | 55.557 | 27.337 | 1.584 |
| 12 | 289 | 92.052 | 27.298 | 1.606 |

Table 13: Number of Probe Reports, 10-Interval Schedule: 5:30-5:40pm

| Link | Number | Mean | S.D. | S.E. |
|------|--------|---------|---------|--------|
| 1 | 154 | 67.045 | 21.473 | 1.730 |
| 2 | 147 | 61.585 | 27.927 | 2.303 |
| 31 | 121 | 72.934 | 34.112 | 3.101 |
| 32 | 42 | 38.214 | 19.226 | 2.967 |
| 4 | 40 | 137.450 | 53.619 | 8.478 |
| 5 | 39 | 40.436 | 15.988 | 2.560 |
| 6 | 47 | 86.915 | 50.666 | 7.390 |
| 7 | 25 | 350.880 | 166.345 | 33.269 |
| 8 | 45 | 105.533 | 55.413 | 8.261 |
| 9 | 39 | 243.308 | 78.055 | 12.499 |
| 10 | 150 | 85.140 | 24.848 | 2.029 |
| 11 | 142 | 51.979 | 25.701 | 2.157 |
| 12 | 142 | 92.324 | 28.060 | 2.355 |

Table 14: Number of Probe Reports, 10-Interval Schedule: 5:40-6:00pm

| Link | Number | Mean | S.D. | S.E. |
|------|--------|---------|---------|--------|
| 1 | 321 | 69.751 | 23.337 | 1.303 |
| 2 | 313 | 56.588 | 27.404 | 1.549 |
| 31 | 227 | 63.626 | 33.365 | 2.214 |
| 32 | 97 | 42.557 | 23.196 | 2.355 |
| 4 | 95 | 114.653 | 46.692 | 4.791 |
| 5 | 91 | 37.209 | 3.388 | 0.355 |
| 6 | 86 | 59.116 | 28.922 | 3.119 |
| 7 | 79 | 308.886 | 134.469 | 15.129 |
| 8 | 102 | 111.676 | 78.960 | 7.818 |
| 9 | 110 | 220.273 | 95.963 | 9.150 |
| 10 | 358 | 82.684 | 20.716 | 1.095 |
| 11 | 332 | 53.178 | 30.174 | 1.656 |
| 12 | 315 | 82.575 | 22.228 | 1.252 |

Table 15: Number of Probe Reports, 10-Interval Schedule: 6:00-6:45pm

| Link | Number | Mean | S.D. | S.E. |
|------|--------|---------|---------|-------|
| 1 | 479 | 69.541 | 22.436 | 1.025 |
| 2 | 471 | 51.892 | 28.493 | 1.313 |
| 31 | 295 | 61.725 | 29.450 | 1.715 |
| 32 | 198 | 35.303 | 14.624 | 1.039 |
| 4 | 216 | 100.148 | 34.021 | 2.315 |
| 5 | 225 | 37.747 | 9.064 | 0.604 |
| 6 | 222 | 48.563 | 20.518 | 1.377 |
| 7 | 222 | 139.180 | 103.603 | 6.953 |
| 8 | 150 | 78.673 | 37.292 | 3.045 |
| 9 | 234 | 107.970 | 78.674 | 5.143 |
| 10 | 510 | 68.873 | 28.973 | 1.283 |
| 11 | 480 | 45.756 | 27.617 | 1.261 |
| 12 | 475 | 75.046 | 19.175 | 0.880 |

Table 16: Number of Probe Reports, 10-Interval Schedule: 6:45-7:00pm

| Link | Number | Mean | S.D. | S.E. |
|------|--------|--------|--------|-------|
| 1 | 277 | 65.025 | 20.810 | 1.250 |
| 2 | 266 | 52.444 | 24.249 | 1.487 |
| 31 | 136 | 52.897 | 23.086 | 1.980 |
| 32 | 147 | 34.789 | 14.014 | 1.156 |
| 4 | 137 | 89.584 | 22.193 | 1.896 |
| 5 | 139 | 35.921 | 3.235 | 0.274 |
| 6 | 139 | 43.122 | 8.523 | 0.723 |
| 7 | 155 | 85.503 | 39.511 | 3.174 |
| 8 | 143 | 69.559 | 17.065 | 1.427 |
| 9 | 162 | 71.358 | 42.594 | 3.346 |
| 10 | 299 | 59.211 | 35.133 | 2.032 |
| 11 | 268 | 43.056 | 23.777 | 1.452 |
| 12 | 289 | 72.232 | 17.561 | 1.033 |

3.3 Data Analysis

Besides updating link travel times, SP is also designed to construct and update a number of other quantities. Included among these are congested distance (the distance traversed by the probe vehicle at a speed of less than ten meters per second), congested time (the time during which the vehicle is stationary or traveling at a speed of less than two meters per second) and some detector-based quantities. These other estimates were only for internal TRF use and had no direct role in route guidance. It is our understanding that in recent revisions of the TRF design, these elements are no longer needed. Hence they were not included in the evaluation plans and were not evaluated as a part of this task. However, the updating procedures for these other quantities are identical to the link travel time updating procedure.

3.3.1 Data Sources

Link travel times are computed in two different ways: based on probes alone and based on both probe reports and detector reports. In the latter case, travel times are obtained from the Data Fusion component of TRF. Since very few links in the ADVANCE area have detectors, link travel times based on probes only are overwhelmingly the more important. Nevertheless, both types of travel times are updated by the SPU procedure. In the present evaluation we have examined both, although we have paid considerably more attention to the probes only case.

3.3.2 SPU Runs

The NFM estimates were originally constructed for June 5, 1995, using data created by the Network Flow Model. Their accuracy is improved by subsequent runs using probe data from specific time periods. After the BD for June 5, five SPU runs were made. Run 1, using the BD from June 5, utilized data from June 6–June 18. Run 2, using the SP from Run 1, was run through the algorithm incorporating data from June 16–July 9. Run 3 used the SP from Run 2, as well as data from July 10–August 4. Both the original run, as well as runs 1 through 3, divided the 1pm–6pm test frame into 2 time intervals, peak and non-peak. The remainder of the day, 6pm–1pm, was considered as one interval.

A second series of runs, paralleling the first, was also made. Rather than using the original interval schedule, this series of runs utilized an alternate interval schedule of 10 time intervals (Table 3 for the 1pm–7pm frame). The remainder of the day, 7pm–1pm, remained in the original one-interval schedule. As with Run 2, Run 4 used the SP from Run 1 as its base, modifying it with data from June 19–July 9. Run 5, using the SP from Run 4, as well as the data from July 10–August 4, followed the same procedure. The time periods and interval schedules for each SP update are shown in the flow chart, Figure 4. This process provided us with two final sets of Static Profile estimates.

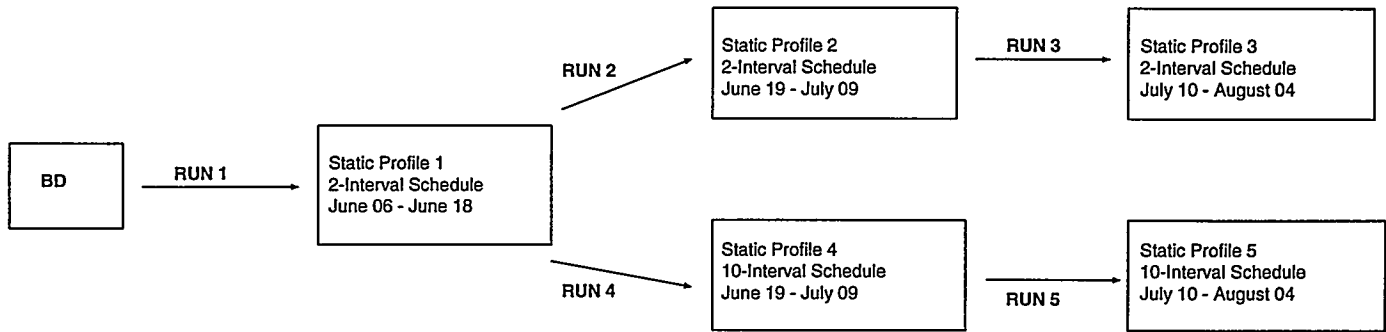

Figure 4: SP Updates: Time Periods and Interval Schedules

4 Base Data - Results

In the analysis of base data we compare various estimates with means and other measures of location or central tendency. We should note here that models of the NFM class tell us what link volumes and link travel times would be if everyone were to choose their shortest travel time routes.

Table 17 shows a comparison of off-peak BD travel time estimates with corresponding means, medians, upper and lower quartiles computed from actual probe data for each of the 12 links. Table 18 is the corresponding table for the peak period. We draw the readers' attention to the fact that for every link and time period, there is one BD estimate. This estimate is computed according to the method described earlier and no claim has ever been made that the estimate is of mean travel time. Precisely for this reason, it is important that we examine how the BD estimate compares with the entire distribution. Consequently, we have presented the four summary measures. These are given in Tables 17 and 18. For comparison of BD estimates with actual probe travel times see the histograms in Figures 9, 12 and 15.

It may be seen that for Links 5, 6 and 8 in the off-peak period and Links 5, 6 and 11 in the peak period, the correspondence of the BD estimate to the probe mean is fairly close. It might be noted that link travel times for Links 5 and 6 are very close to their cruise times, which are the times that would be taken to traverse the links at a constant speed of 35 mph (Link 5) and 25 mph (Link 6). Link 5 is a little traveled link terminating in an uncontrolled right turn, while Link 6 is a little traveled link terminating in a right turn at a stop sign. All other links end at traffic signal controlled intersections.

Overall BD estimates are somewhat disappointing. In order to understand why this might have occurred, we compared link volumes provided by the NFM with volumes obtained from detectors (Tables 19 and 20). While models of the NFM family have been used in the past primarily for estimating volumes, their accuracy in this situation appears limited. There does not seem to be a great deal of correspondence between the travel-time estimate provided by the NFM and the actual volumes recorded by the detectors for either off-peak or peak situations. The closest relationship exists for Link 7, off-peak,

Table 17: Base Data Travel Time Estimates (in seconds), 2-Interval Schedule: Off-Peak

| Link | Base Data | Cruise | MNA 1pm-4pm | | | | | | |
|------|-----------|--------|-------------|-------|-----|-------|-----|-------|-----|
| | 1pm-4pm | Time | mean | stdev | max | Q_3 | med | Q_1 | min |
| 1 | 56 | 45.9 | 75.6 | 22.6 | 278 | 89 | 72 | 56 | 35 |
| 2 | 36 | 29.3 | 43.8 | 30.1 | 255 | 39 | 31 | 28 | 20 |
| 31 | — | — | 62.8 | 31.5 | 212 | 86 | 60 | 39 | 23 |
| 32 | 76 | 22.6 | 30.1 | 16.1 | 161 | 29 | 25 | 23 | 18 |
| 4 | 64 | 54.9 | 95.4 | 33.1 | 213 | 112 | 87 | 70 | 45 |
| 5 | 33 | 32.7 | 36.5 | 4.1 | 74 | 39 | 37 | 34 | 25 |
| 6 | 44 | 43.3 | 45.3 | 9.7 | 159 | 49 | 43 | 39 | 27 |
| 7 | 47 | 33.4 | 107.4 | 52 | 412 | 131 | 106 | 62 | 33 |
| 8 | 55 | 42.3 | 55.6 | 17.6 | 172 | 62 | 51 | 43 | 27 |
| 9 | 105 | 48.1 | 64.0 | 30.5 | 370 | 64 | 56 | 52 | 42 |
| 10 | 32 | 25.8 | 60.3 | 32.7 | 319 | 91 | 58 | 29 | 20 |
| 11 | 35 | 25.7 | 56.6 | 28.9 | 179 | 83 | 62 | 29 | 22 |
| 12 | 61 | 45.9 | 74.9 | 23.6 | 236 | 88 | 71 | 58 | 36 |

Table 18: Base Data Travel Time Estimates (in seconds), 2-Interval Schedule: Peak

| Link | Base Data | Cruise | MNA 4pm-6pm | | | | | | |
|------|-----------|--------|-------------|-------|-----|-------|-------|-------|-----|
| | 4pm-6pm | Time | mean | stdev | max | Q_3 | med | Q_1 | min |
| 1 | 54 | 45.9 | 70.8 | 23.4 | 159 | 83 | 62 | 50 | 39 |
| 2 | 34 | 29.3 | 58.8 | 33.8 | 573 | 84 | 66 | 29 | 22 |
| 31 | — | — | 66.5 | 33.3 | 299 | 87 | 50 | 39 | 22 |
| 32 | 79 | 22.6 | 41.5 | 19.5 | 153 | 53 | 33 | 26 | 20 |
| 4 | 65 | 54.9 | 119.1 | 47.1 | 308 | 148 | 103.5 | 80 | 53 |
| 5 | 33 | 32.7 | 38.0 | 7.5 | 140 | 39 | 37 | 35 | 27 |
| 6 | 53 | 43.3 | 56.8 | 26.6 | 251 | 62 | 47 | 41 | 20 |
| 7 | 56 | 33.4 | 225.4 | 120.8 | 732 | 317 | 191 | 132.5 | 35 |
| 8 | 44 | 42.3 | 104.6 | 73.5 | 723 | 108 | 80 | 66 | 37 |
| 9 | 175 | 48.1 | 198.8 | 107.6 | 850 | 265 | 198 | 101 | 47 |
| 10 | 34 | 25.8 | 82.2 | 25.4 | 230 | 91 | 81 | 66 | 27 |
| 11 | 57 | 25.7 | 52.7 | 31.1 | 206 | 99 | 58 | 46 | 26 |
| 12 | 46 | 45.9 | 85.9 | 35.7 | 974 | 101 | 84 | 60 | 41 |

where the NFM underestimated the detector volume by 16.4 vehicles. Other than that report, volumes vary widely between the NFM estimate and the recorded detector value, the greatest difference being 1287.6 vehicles (Link 1, off-peak).

Table 19: Detector Volumes and NFM Estimates: Off-Peak

| Link ID | Detector Volume | NFM Estimate |
|-------------|-----------------|--------------|
| 8cb40 | 795.2 | 522 |
| 8cae7 11 | 886.2 | 1681 |
| 8cae8 | 493.6 | 198 |
| 8cabf | 1036.0 | 1447 |
| 8cb24 | 529.0 | 498 |
| 88c9a8 7 | 666.4 | 650 |
| 891036 | 890.3 | 561 |
| 88d079 | 412.9 | 558 |
| 88cb2b 1 | 590.4 | 1878 |
| 88cad2 | 1158.4 | 1455 |
| 88cb20 | 1117.8 | 1623 |

Note: Both the Detector Volume and the NFM Estimate are average hourly flows. The detectors are all part of a closed loop system on Dundee Road in the study area. Three links (1, 7 and 11) are on the study route. The other detectorized links are cross-links which intersect with Dundee Road.

Assuming the detector volumes accurately reflect actual traffic flows, the tables showing detector volumes and NFM estimated traffic flows suggest the following:

1. peak flows on Dundee Road are generally overestimated by the Network Flow Model while flows on the cross streets are generally underestimated, although there is no consistent pattern for the off-peak period; this may account for the disappointing performance of the NFM procedure which computes green splits endogenously,
2. volumes on the cross streets are generally modeled more accurately than those on arterials, and
3. NFM volume estimates vary widely enough that travel time estimates are compromised.

Again, the NFM estimates are not as accurate as they might be. While the principle upon which the NFM model is based (every one chooses his/her minimum time route) may be challenged, it is unlikely that such models, when accurate inputs are provided, would not yield estimates that approximate true traffic volumes. Thus we surmise that either the cost functions used were inappropriate or the OD volumes, which were constructed

Table 20: Detector Volumes and NFM Estimates: Peak

| Link ID | | Detector Volume | NFM Estimate |
|---------|----|-----------------|--------------|
| 8cb40 | | 1124.4 | 999 |
| 8cae7 | 11 | 1172.2 | 2134 |
| 8cae8 | | 720.4 | 373 |
| 8cabf | | 1376.5 | 1196 |
| 8cb24 | | 799.4 | 372 |
| 88c9a8 | 7 | 979.1 | 958 |
| 891036 | | 679.6 | 246 |
| 88d079 | | 1246.0 | 487 |
| 88cb2b | 1 | 566.5 | 1792 |
| 88cad2 | | 1411.1 | 558 |
| 88cb20 | | 1221.7 | 1811 |

Note: Both the Detector Volume and the NFM Estimate are average hourly flows. The detectors are all part of a closed loop system on Dundee Road in the study area. Three links (1, 7 and 11) are on the study route. The other detectorized links are cross-links which intersect with Dundee Road.

partially on the basis of 1990 data, were obsolete. The latter observation is especially relevant in a fast growing region such as the ADVANCE test area. We shall see later that the mean travel times for some of the links are not constant over time. Thus conditions change and we cannot expect BD estimates which remain constant to remain accurate over the long term.

5 Static Profile Update - Results

Data analyzed in this section were collected as described earlier in this document. Using a targeted deployment in a limited study area, probe vehicles collected data in separate time periods, data which were then utilized in sequential Static Profile Update runs to create estimates of travel times for specific links.

5.1 Updates 1, 2 and 3: 2-Interval Schedule

Table 21 shows the means of probe travel times for the 1-4 pm period for all days for which data were gathered for TRF evaluation. Also shown are the 3 updates (made for June 18, July 09 and August 04) and, for the readers' convenience, the BD estimates.

For SP estimates the mean is the appropriate measure of travel time, at least for evaluation purposes, because the aim of the SPU was to yield estimates of the mean 'under normal conditions', which we took to mean incident-free conditions. Therefore,

Table 21: Static Profile Travel Time Estimates (in seconds), 2-Interval Schedule: Off-Peak

| Link | BD | SPU 1 | | SPU 2 | | SPU 3 | |
|------|-----|-------|-------|-------|-------|-------|-------|
| | | est | probe | est | probe | est | probe |
| 1 | 56 | 64.42 | 70.7 | 69.59 | 72.5 | 74.4 | 79.8 |
| 2 | 36 | 47.53 | 52.7 | 45.22 | 44 | 42.27 | 40.8 |
| 31 | — | 56.88 | 67.9 | 60.4 | 63.9 | 59.96 | 61 |
| 32 | 76 | 27.10 | 29.6 | 30.06 | 31.6 | 29.66 | 29.2 |
| 4 | 64 | 84.76 | 95.6 | 92.8 | 96.6 | 93.42 | 94.3 |
| 5 | 33 | 34.84 | 36.1 | 36.02 | 36.5 | 36.31 | 36.8 |
| 6 | 44 | 44.23 | 44.4 | 44.94 | 45.4 | 45.15 | 45.5 |
| 7 | 47 | 91.17 | 97 | 98.04 | 103.2 | 102.6 | 114.8 |
| 8 | 55 | 55.89 | 54.4 | 55.53 | 55.4 | 55.69 | 56.2 |
| 9 | 105 | 58.16 | 61.2 | 63.71 | 68.1 | 62.1 | 61.2 |
| 10 | 32 | 57.09 | 57.6 | 61.06 | 65.3 | 59.27 | 57.7 |
| 11 | 35 | 51.37 | 59.7 | 55.15 | 57.7 | 55.03 | 54.7 |
| 12 | 61 | 67.29 | 71.9 | 72.03 | 80.4 | 71.86 | 71.7 |

Note: For Tables 21 and 22, “est” refers to the SPU estimate of mean travel time and “probe” refers to the average travel time for that link as determined from actual probe data gathered in that time period (see Table 4).

the means used for comparisons do not include values from link reports where incidents were noted. It is also appropriate that SP estimates were designed to approximate the mean because estimates of travel times are used to estimate *route travel times* and the mean of route travel times is the sum of mean travel times of the links comprising the route. This property is not shared by all measures of location (e.g., the median or the mode).

It is apparent that the estimates are quite accurate in that they are quite close to the means of probe reported travel times, a point which is particularly true for the third update. Even when the BD estimates are relatively inaccurate, the corresponding SP estimate moves rapidly towards a more realistic value (in terms of actual data). This is particularly evident if we compare the overall means of probe travel times in Table 17 with the SPU 3 travel-time estimates in Table 21. It may be seen that there is a fair amount of variation from updating interval to updating interval for the same link. Therefore, it would be unreasonable to anticipate smaller differences between the means from one SP to the next. For example, consider Link 7 where the third SP estimate of 102.6 seconds has the largest difference (12.2 seconds) of all estimates from the corresponding mean probe report. While the first update shows good recovery from a rather inaccurate BD estimate, updating interval probe travel time means of 97, 103.2 and 114.8 seconds provide too much of a moving target. However, a discrepancy of 12.2 seconds for an average travel

time of over 100 seconds is hardly disastrous.

Table 22: Static Profile Travel Time Estimates (in seconds), 2-Interval Schedule: Peak

| Link | BD | SPU 1 | | SPU 2 | | SPU 3 | |
|------|-----|--------|-------|--------|-------|--------|-------|
| | | est | probe | est | probe | est | probe |
| 1 | 54 | 64.1 | 71.1 | 66.92 | 68.9 | 69.09 | 72.3 |
| 2 | 34 | 57.28 | 62.3 | 58.47 | 59.5 | 58.06 | 56.6 |
| 31 | — | 61.71 | 65.3 | 63.85 | 65.7 | 65.27 | 67.8 |
| 32 | 79 | 35.13 | 40 | 39.75 | 40.7 | 41.22 | 42.2 |
| 4 | 65 | 94.63 | 104 | 112.82 | 117.9 | 116.5 | 120.5 |
| 5 | 33 | 36.11 | 37.2 | 36.79 | 37.5 | 37.7 | 38.2 |
| 6 | 53 | 52.73 | 52.4 | 54.56 | 54.5 | 56.23 | 58.3 |
| 7 | 56 | 204.38 | 244.8 | 200.2 | 200 | 219.35 | 238.8 |
| 8 | 44 | 113.4 | 134 | 76.56 | 75.6 | 82.11 | 118.3 |
| 9 | 175 | 231.71 | 255.3 | 177.83 | 155.3 | 196.44 | 218.7 |
| 10 | 34 | 82 | 91.8 | 80.45 | 79.8 | 80.36 | 80.4 |
| 11 | 57 | 65.36 | 60.7 | 49.17 | 44.5 | 51.4 | 56.7 |
| 12 | 46 | 75.27 | 83.7 | 81.48 | 94.2 | 80.45 | 79.3 |

Table 22 shows a comparison of mean link travel times and SP estimates for the peak period. Again, the overall performance of the SP procedure seems good. One of the third SP updates, Link 8, is relatively inaccurate. The circumstances leading to this discrepancy are unusual. The means of probe reports for the three update intervals are 134, 75.6 and 118.3 seconds. Not only is the mean for the second interval much smaller than the others, its variance is also small, giving the impression to the update algorithm that it is more reliable than the other estimates. Note also that while it does not have as dramatic an effect on SP estimates, a similar phenomenon exists for Links 7, 9 and 11, to a lesser extent for Link 10, and in a reverse direction for Link 12 (although Link 12 is a right-turning link). Note also that Links 8 through 12 are consecutive links. A possible explanation for this fluctuation is that some experimentation occurred with traffic signal timings.

Clearly, the dramatic fluctuation in probe travel times Link 8 experienced affected the estimate. Because of two reports which had travel times close to 1000 seconds, the average travel time was affected. However, because no incidents were noted for these reports, they were not deleted from our data set. In order to guard against such situations, the SP algorithm as designed had incorporated a test which would warn of such events and take some evasive actions. However, the test was not implemented. It is not clear whether the test would have been able to handle such a dramatic shift in mean travel time in one direction and then the other. Perhaps that part of the algorithm needs to be revised in light of the experience gained from Link 8. We could however argue that in this case

the probe means were the less good estimates of travel time; the SP estimates were more robust and therefore better. Ideally, we would also get information when changes are made to traffic signal timings.

5.1.1 Comparison of Travel Times with BD and Final SPUs

The data examined in the tables above can also be displayed and examined as histograms. The advantage of histograms is that they afford a comparison with the entire distribution. In histograms Figures 5-8, the upper arrow (or the only arrow, if only one is visible) shows the location of SPU3 and the lower arrow is the corresponding BD estimate. On some occasions the BD estimate falls outside the figure's range and is therefore not shown. The actual estimates are printed above each histogram.

Figures 5 and 6 portray the variations in travel times during the off-peak period for the twelve links of the long route. Each day of data collection has one average travel time for the 4:00 - 6:00 peak period and the 1:00 - 4:00 pm off-peak period. This is represented by a single observation on the histograms. The distribution for Link 1 in the off-peak period is typical. While the BD is only 56 seconds and therefore off the histogram, SPU3 represents the midpoint of the range of average travel times. The SPU3 estimate of travel time is 74.4 seconds and the mode (most frequently occurring value) in the distribution occurs at the 76-77 second level.

At the intersection of Dundee Road and Northgate Parkway, the two approaching links on our study route (Links 32 and 9) have BD levels higher than SPU3 and the differences are large. In the case of Link 32 the BD is more than twice the SPU3 and for Link 9 it is almost 70% higher. Perhaps some aspect of the intersection, such as the green time input to the NFM, did not accurately reflect actual conditions. Still, in both cases the SPU3 estimate portrays the most common driving circumstance reasonably well. Even the outlier in Link 9 does not greatly influence the magnitude of SPU3.

During the peak period (Figures 7 and 8) the pattern is similar but not identical. The BD is generally below the range of the daily averages (during the peak period) and again Link 32 is an exception. During the peak period Link 32 has a difference between BD and SPU3 which is of the same magnitude as in the off-peak case.

Again the final 2-interval SPU (SPU3) portrays the actual travel times with reasonable accuracy. Also, as in the off-peak period, Links 5 and 6, which almost never experienced congestion in the middle of the link, exhibit a small difference between the BD and SPU3 values.

In ten of the twelve links the BD is less than SPU3. Given the growth of the region in which in the study area is located it is possible the data input to the NFM and used to compute the BD were out of date.

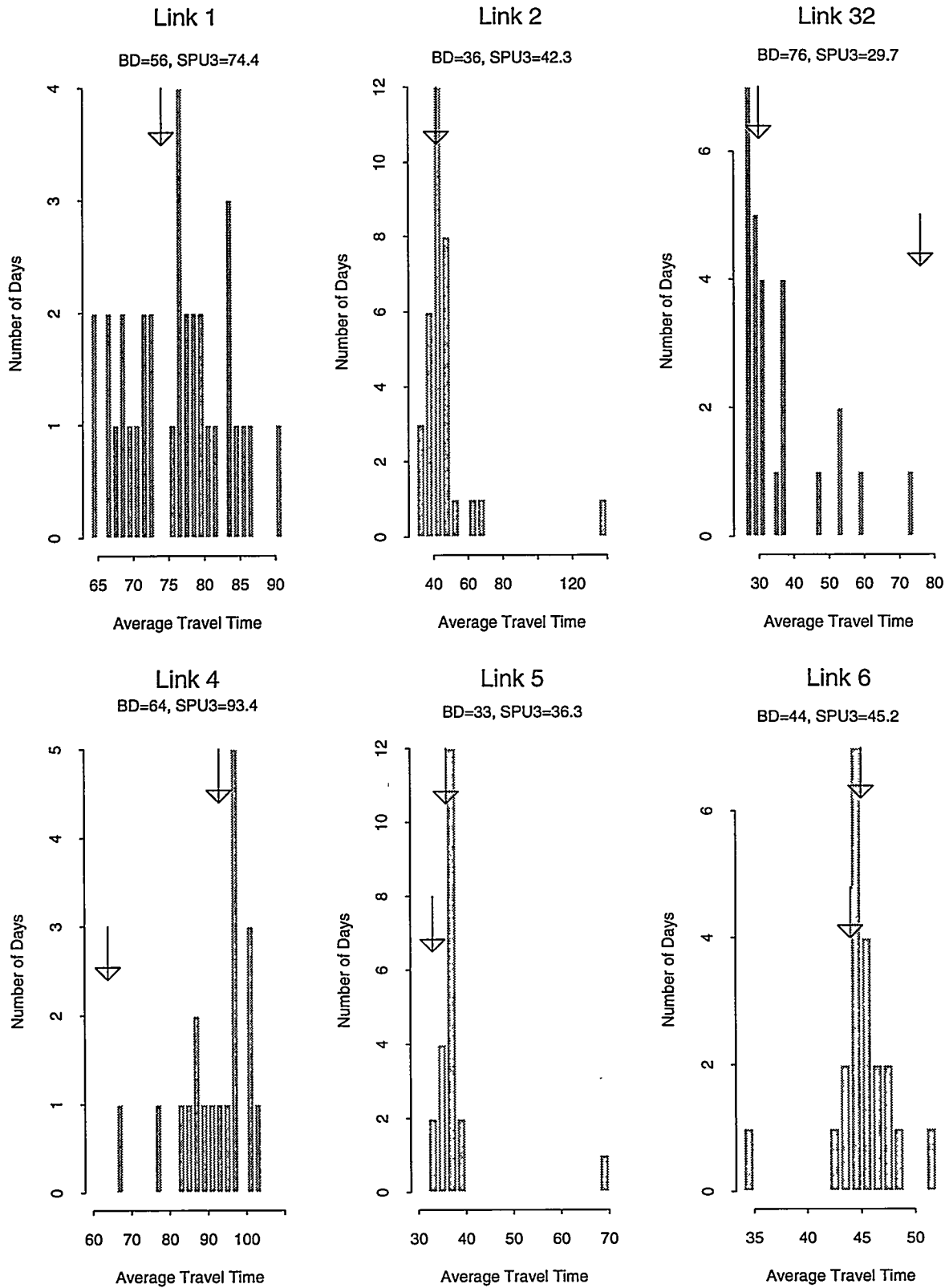

Figure 5: Average Travel Time (in seconds) by Number of Days, Links 1-6: Off-Peak

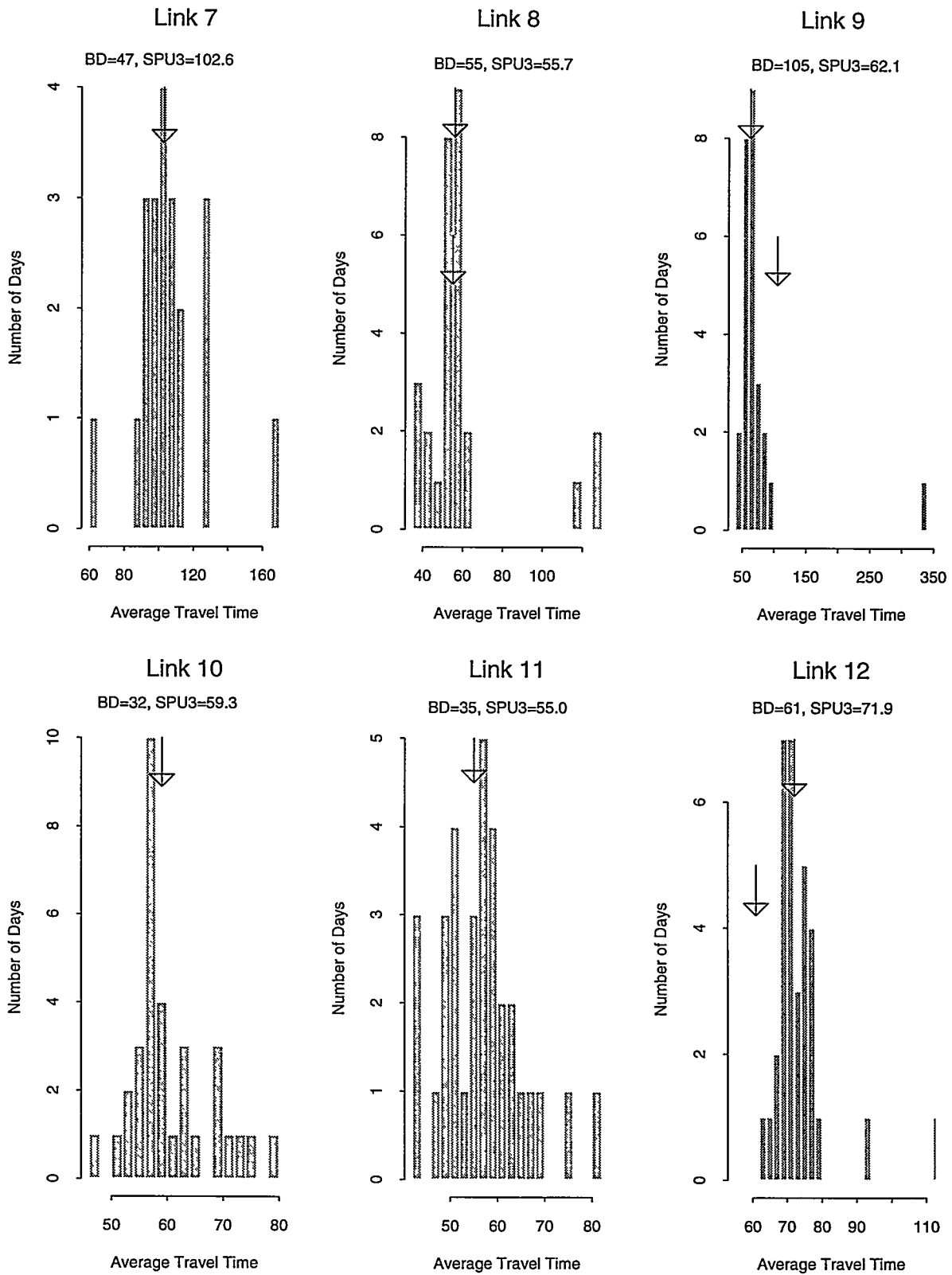

Figure 6: Average Travel Time (in seconds) by Number of Days, Links 7-12: Off-Peak

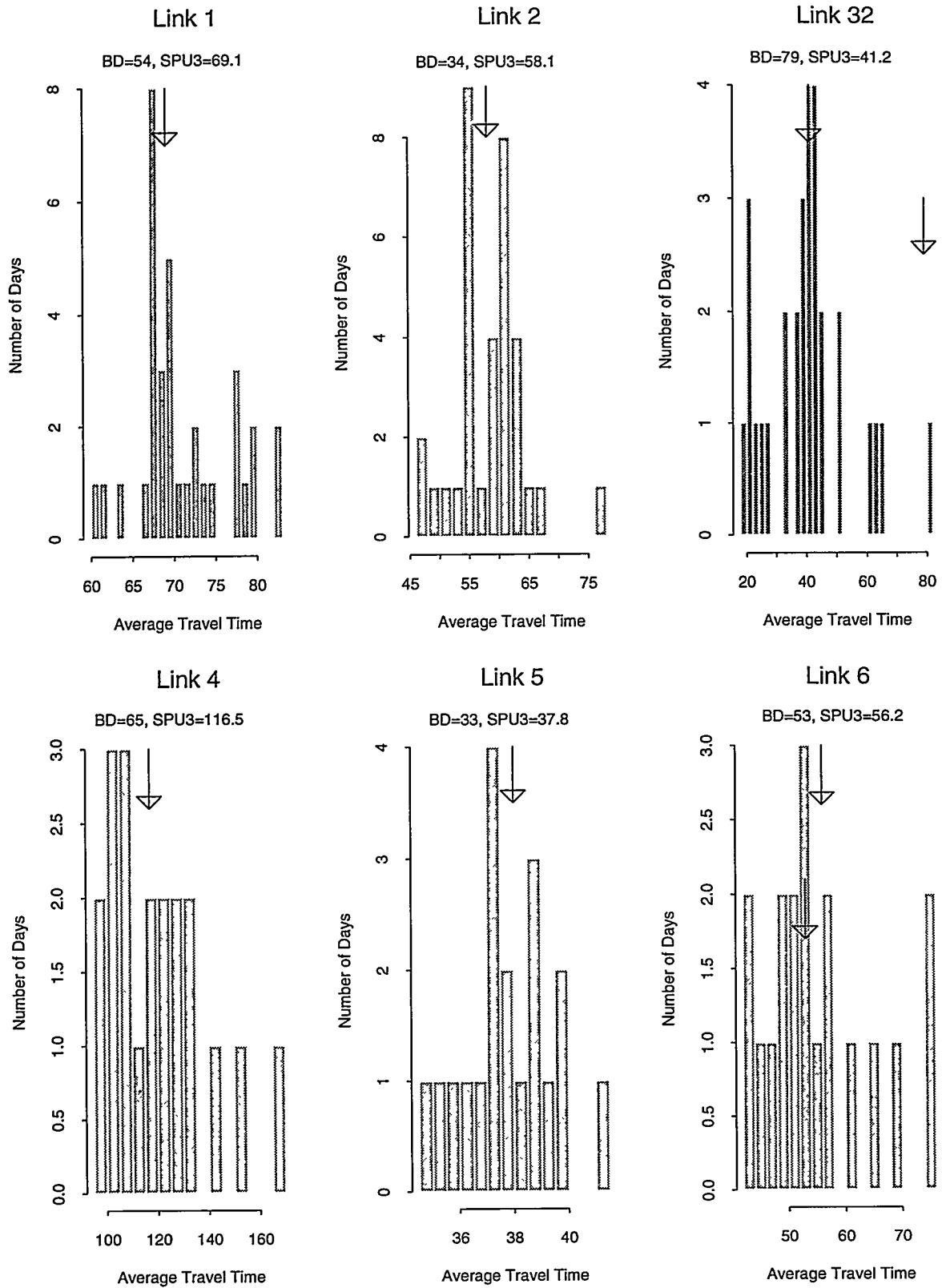

Figure 7: Average Travel Time (in seconds) by Number of Days, Links 1-6: Peak

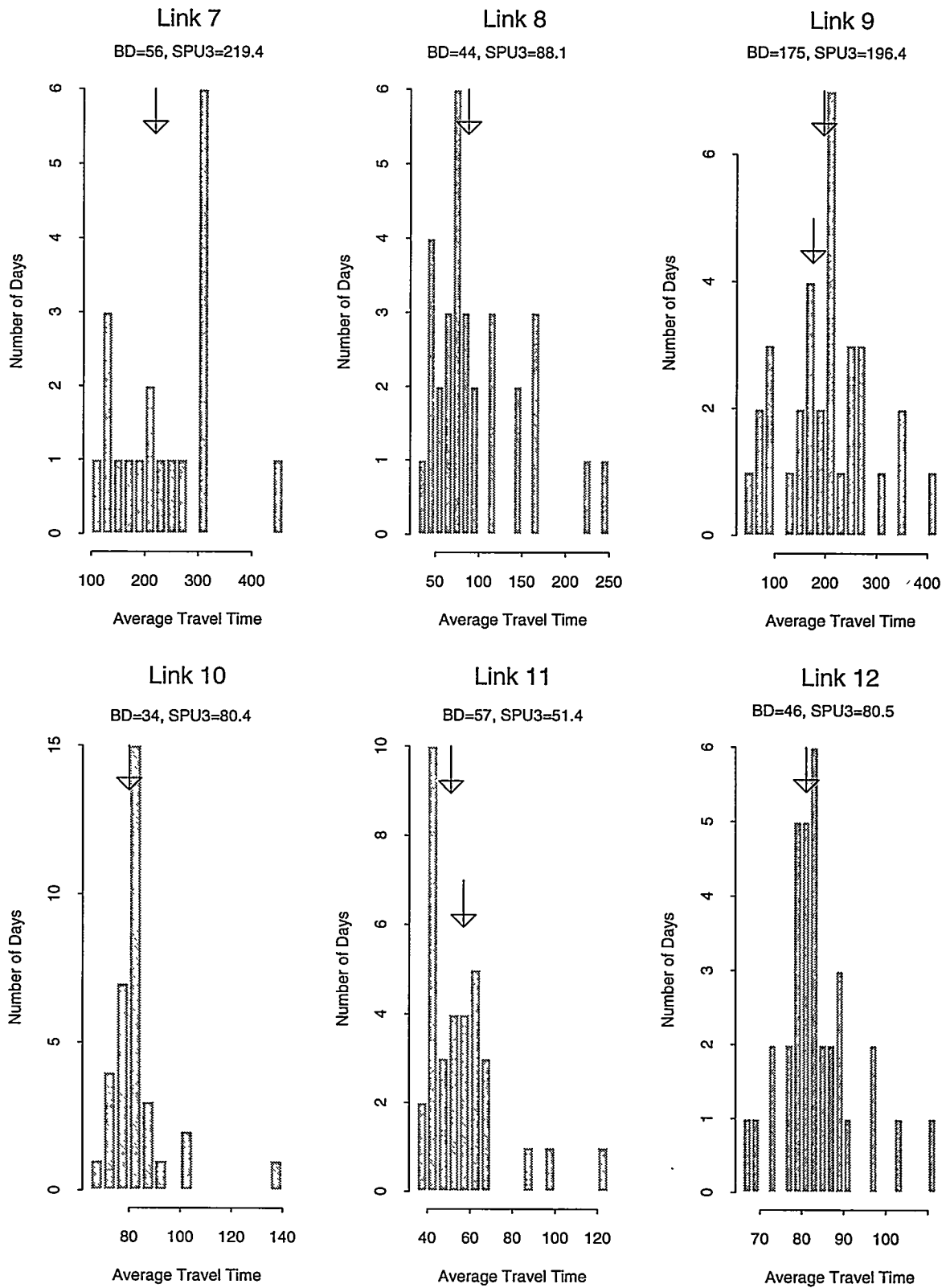

Figure 8: Average Travel Time (in seconds) by Number of Days, Links 7-12: Peak

5.1.2 Evaluation of SP and BD as Forecasts

Until now we have examined the quality of SP and BD estimates in terms of how well they described probe observations as a whole and, in particular for SP estimates, how close they came to the mean of probe observations. Both BD and SP estimates are used within the ADVANCE system as forecasts, albeit as default ones. Therefore, it is appropriate to also examine them in the context of this role. After all, the whole purpose of TRF algorithms is to make forecasts.

BD estimates are used as forecasts until the first SP estimates (SP1 in our case) are available. Then SP1 estimates are used until SP2 estimates are available. Then SP3 estimates would be used. It would be interesting to see how well BD estimates perform with respect to the actual link travel times during the time they are being used as forecasts. Similarly, it would be useful to examine how well SP1 estimates and SP2 estimates compare with link travel times during the time they would be used as forecasts. Obviously, we cannot examine SP3 estimates in the same way since no data were collected after they were constructed. Clearly, if the SP and BD estimates accurately reflect the actual condition on links during the time they are being used, there would be less need for dynamic broadcasts — a desirable situation. The best data available on link travel times are probe reported travel times. Since dynamic estimates are constructed over 5-minute intervals, we decided to compare SP and BD estimates with means of probe travel times over 5-minute intervals. Therefore, we subtracted the appropriate SP or BD estimate from such means and displayed the differences as histograms. That is, each histogram was constructed in the following way:

- means for 5-minute intervals contained in the appropriate update and SP interval were computed,
- the corresponding SP or BD estimate was subtracted from these means, and
- the numbers obtained in this way were displayed as histograms.

Clearly, values close to zero reflect cases where the probe means were very similar to the corresponding estimate. This process was repeated for every SP interval and update interval.

The resultant histograms (Figures 9 to 15) show that the SP estimates, particularly the SP2 estimates perform very well in this role. Since in the implementation of ADVANCE, dynamic estimates are broadcast only if they differ from current SP or BD estimate by 20 seconds, it is easily seen that in several of the links examined (e.g., Links 2, 5, and 6), dynamic broadcasts would not occur very often under non-incident conditions. For some links (e.g., Link 7) the 5-minute mean is spread out so widely that no 60-second interval could cover them. Even in these cases, the SP2 estimates are positioned so near the center of the empirical distribution of these means that the number of times dynamic broadcasts would occur is minimal. Unfortunately, as would be expected from our earlier discussion, BD estimates do not perform as well.

5.1.3 BD and SPU as Forecasts: Off-Peak Period

The first set of histograms (Figures 9 to 11) in this section shows the the frequency of BD, SPU1 and SPU2 values subtracted from the five-minute period average travel times. In an ideal situation the distribution would be centered close to zero. The fact that the values are mainly positive reflects the earlier discussion of low BD values.

Figure 10 shows how quickly the SP values reflect the summer 1995 driving conditions. This figure shows the average five-minute travel times during the off-peak during the period from June 19–July 9 minus the SPU1 based on the driving activities in the period June 5–June 16 and the initial BD. The distributions are rather varied but the zero level generally appears, as it should, near the center of the distribution.

The SP is again updated using the data of Figure 10 and this update is used to forecast for the following data collection period, July 10–August 4. Figure 11 shows the results and in summary there are no substantial changes. Some of the distributions have assumed different shapes, but the zero level remains near their centers. Link 12 shows the most improvement. The previous SPU resulted in only positive differences (Figure 10) whereas in the final version the zero level (no difference between probe travel time and SP estimate) is near the center of the distribution.

While the mean is the most appropriate single number to compare with SP estimates, comparing the estimates with histograms reveals some additional important points. Optimally, we would want static (default) estimates to be accurate to the point that under incident-free conditions, dynamic estimates would only be broadcast rarely. The fact that SP estimates are close to the mode of the histograms shows they perform well in this capacity.

In the ADVANCE project, as implemented, dynamic broadcasts are relayed if dynamic estimates differ from static estimates by more than 20 seconds. Therefore, the histograms show that if dynamic estimates were the actual travel times, for many links there would rarely be a need to broadcast them under incident-free conditions. The links which constitute exceptions to this observation have ranges of travel times too wide to fit within 60 seconds. Overall, the SP estimates seem to perform exceptionally well in this regard.

5.1.4 BD and SPU as Forecasts: Peak Period

During the peak period the general rate of improvement is similar to that discussed above for the off-peak period. The initial comparison (Figure 12) shows that the corresponding subtraction of actual travel times minus BD are mainly positive. Link 32 remains a problem and there are some negative values for both Link 6 and Link 11, where the BD appears to be a good predictor of travel times.

By applying the first SPU the improvements are again substantial (Figure 13). Only Link 8 appears to have an undesirable result. The majority of the values for this link are negative and they are not balanced at zero like they are for the other links. This problem is cleared by the next SPU (Figure 14) where the distribution seems centered on the zero

level despite the extremely high outlier (over 600) which is barely visible on the figure. Note that the mean was adversely affected by this outlier and hence, on the basis of the histogram, the SP estimate seems much more accurate. In general the links in this last update have travel distributions which reflect SPU2.

Since it is hard to visualize the change portrayed by three set of histograms over three pages we display two sample links on one page (Figure 15). These two links, Link 10 and Link 11, have different travel time frequency distributions and, by chance, different relationships with the BD/SP antecedents are evident. Link 10 has a symmetric distribution for all three time periods and, after the poor fit with BD (all differences are positive), the second two distributions appear to be well centered on the zero level.

The distribution of Link 11 starts out being positively skewed and remains so for the other two periods, although the skewness declines. In this case, however, the BD is a reasonable predictor of travel time. The first SPU seems to overestimate by only a small amount and the bulk of the distribution is less than zero. By the last SPU the distribution is more symmetric and, more importantly, it is more centered on the zero value than in the previous case. Link 11 is an exception in that most other links follow the pattern of Link 10 where the BD is not a good predictor of travel time and the first SPU is a vast improvement.

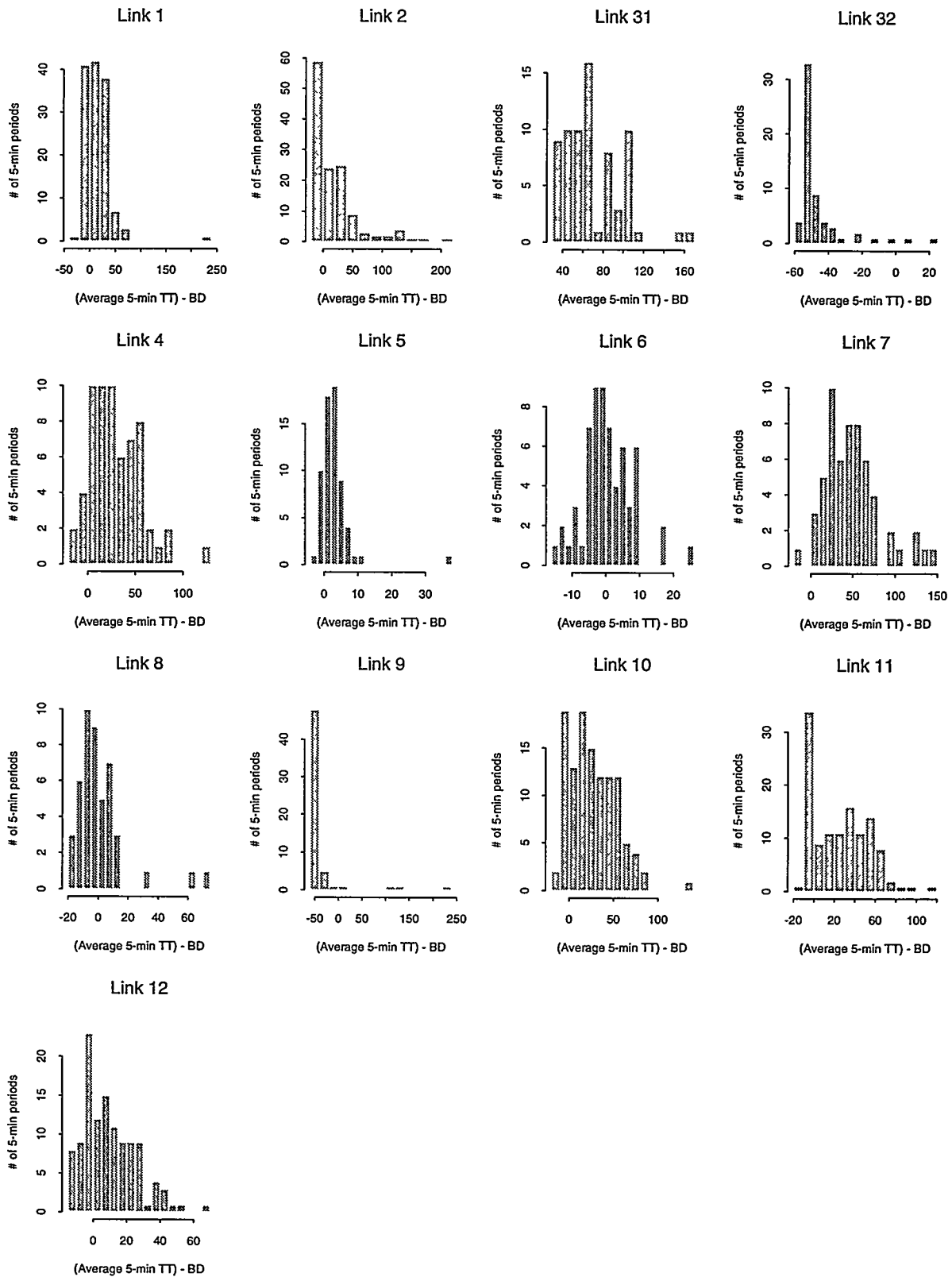

Figure 9: Difference between Average 5-minute Travel Time and BD Estimate (in seconds) by Number of 5-minute periods: Off-Peak

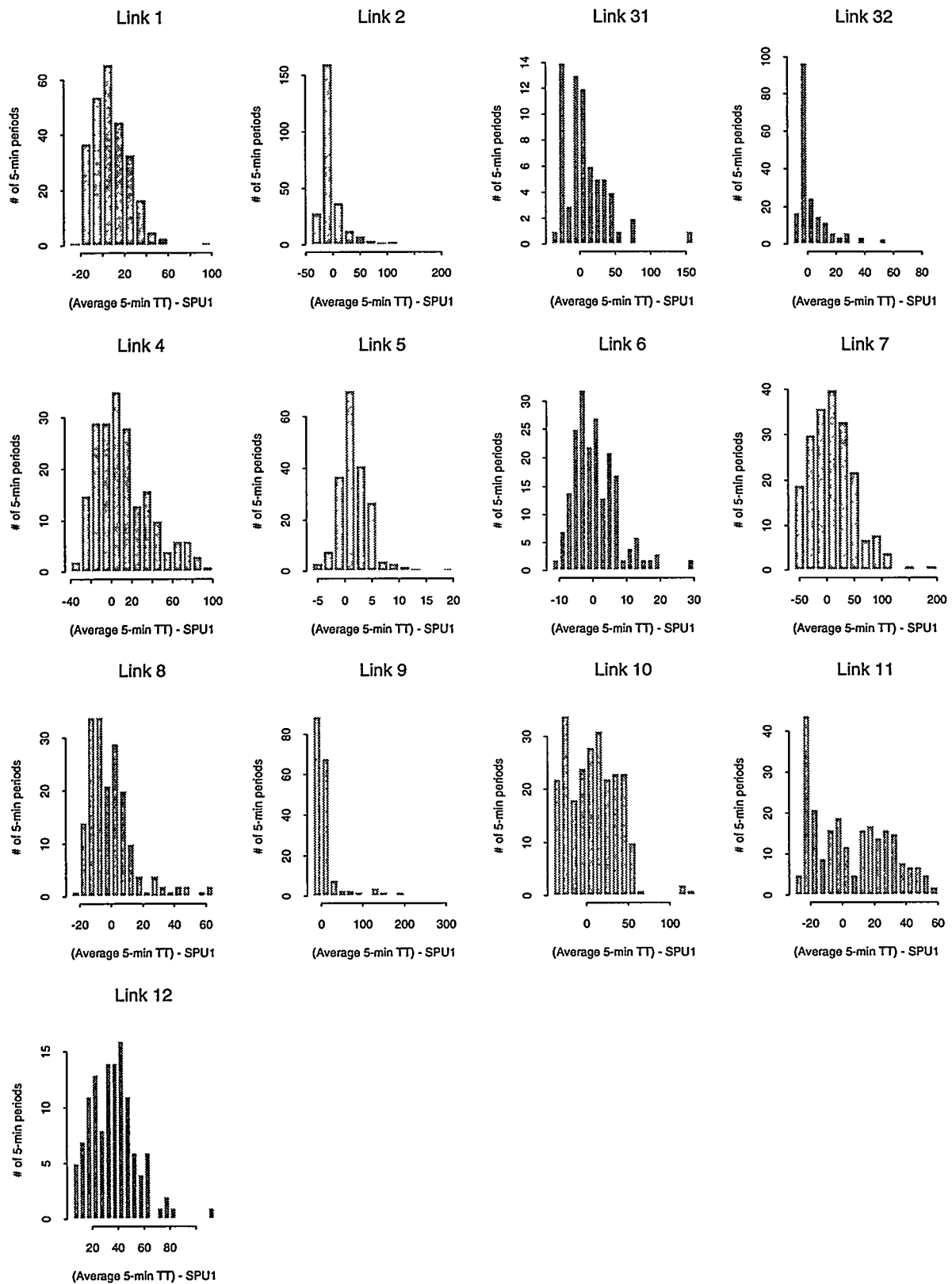

Figure 10: Difference between Average 5-minute Travel Time and SPU1 Estimate (in seconds) by Number of 5-minute periods: Off-Peak

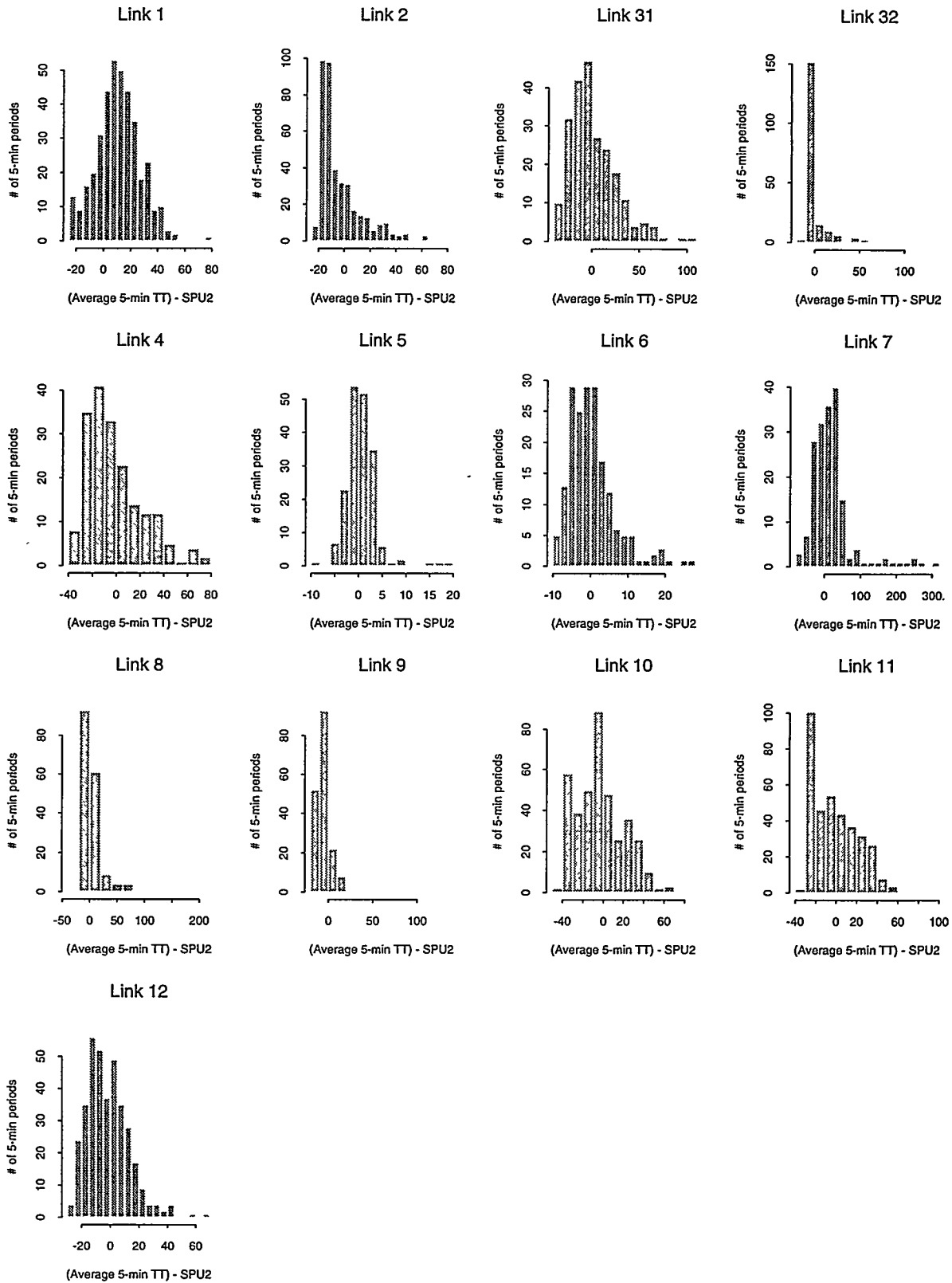

Figure 11: Difference between Average 5-minute Travel Time and SPU2 Estimate (in seconds) by Number of 5-minute periods: Off-Peak

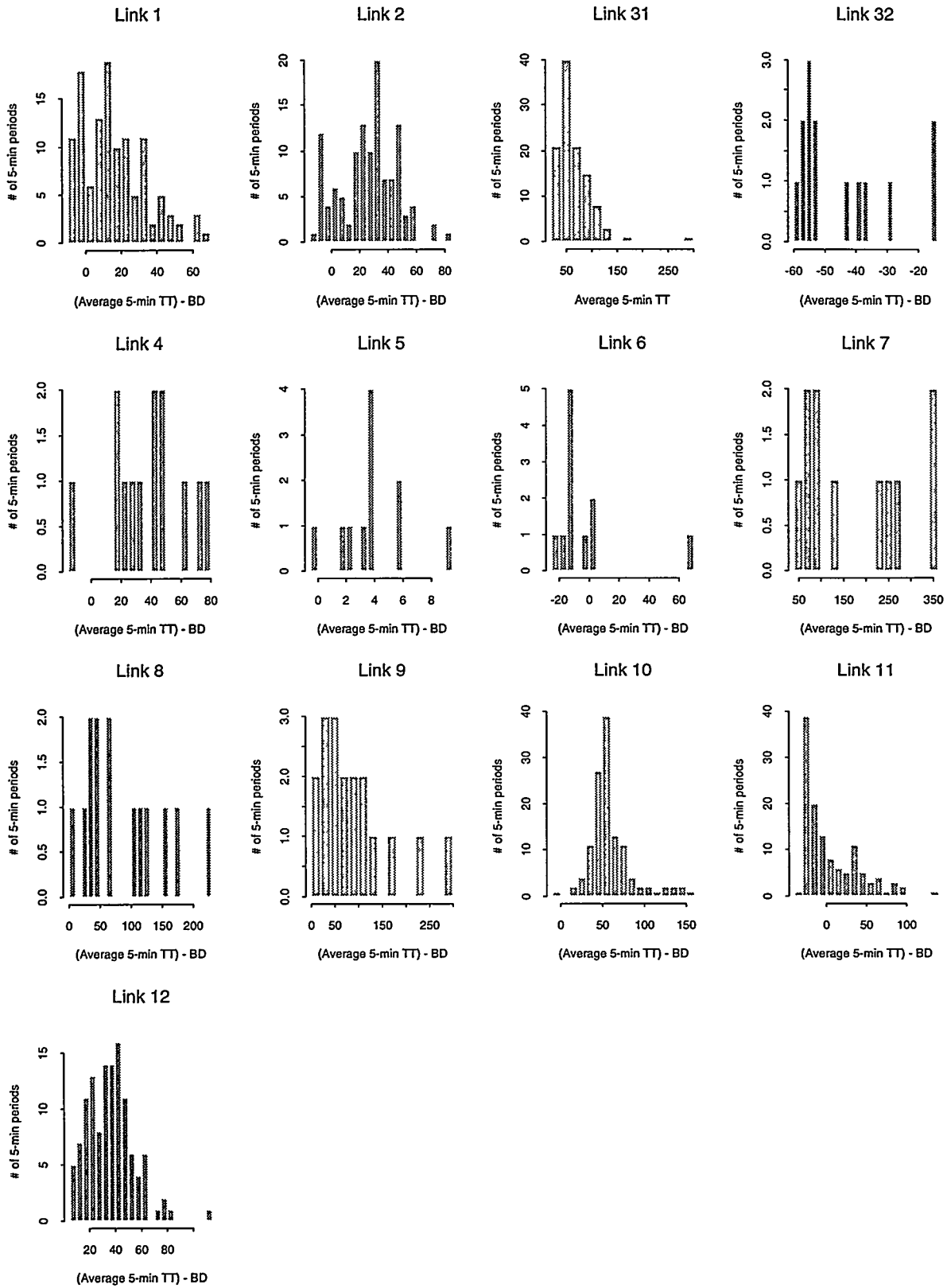

Figure 12: Difference between Average 5-minute Travel Time and BD Estimate (in seconds) by Number of 5-minute periods: Peak

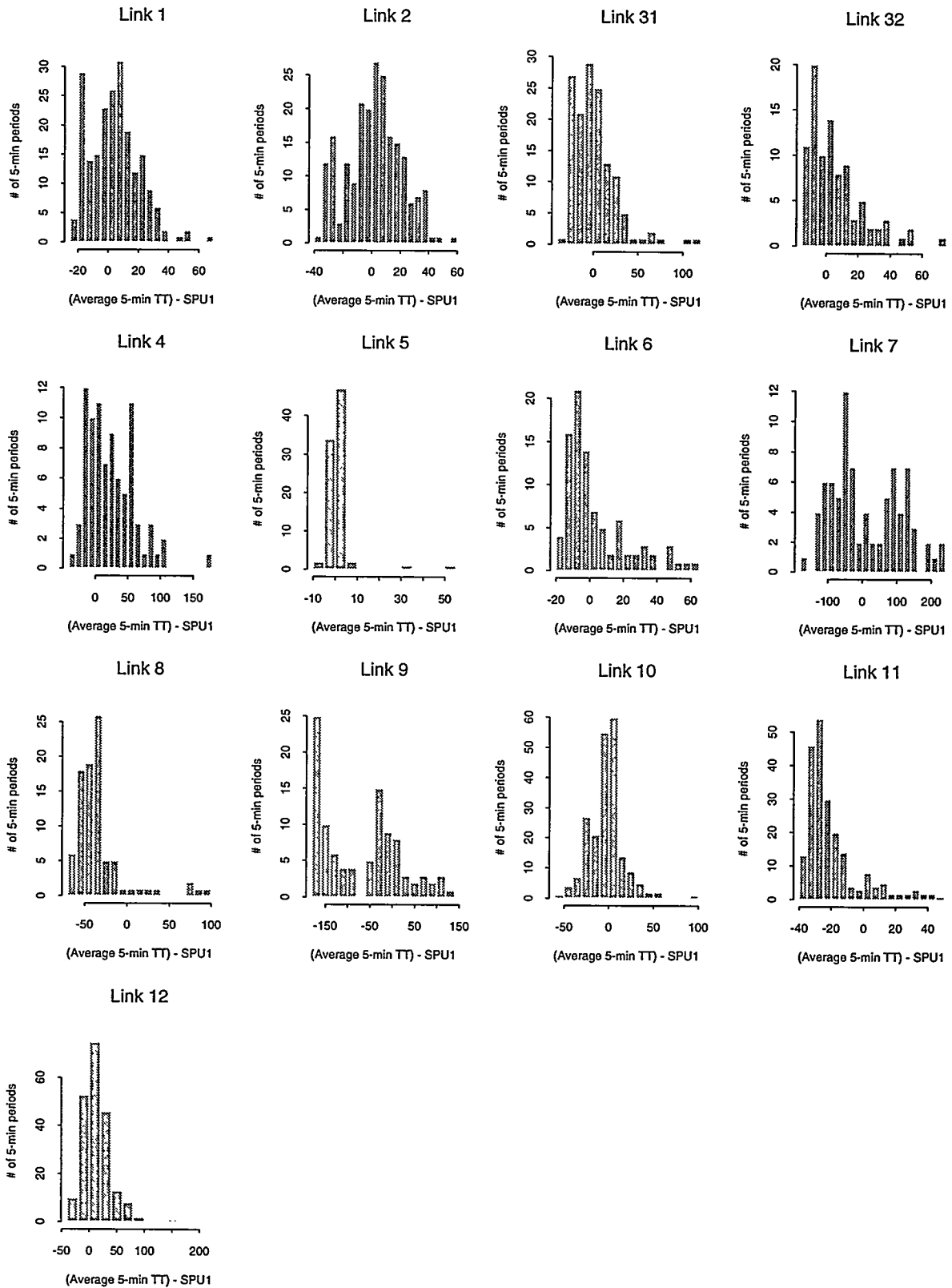

Figure 13: Difference between Average 5-minute Travel Time and SPU1 Estimate (in seconds) by Number of 5-minute periods: Peak

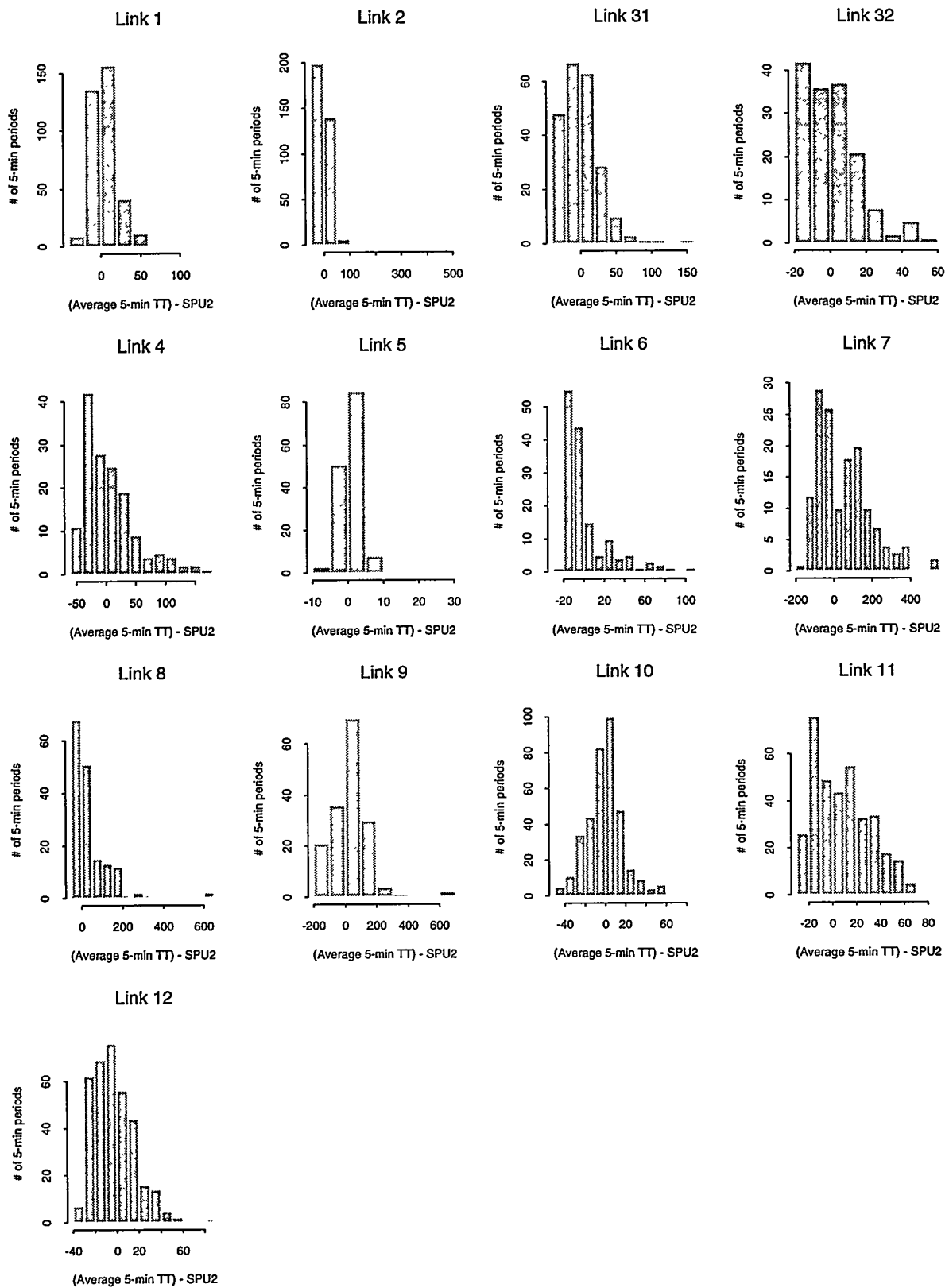

Figure 14: Difference between Average 5-minute Travel Time and SPU2 Estimate (in seconds) by Number of 5-minute periods: Peak

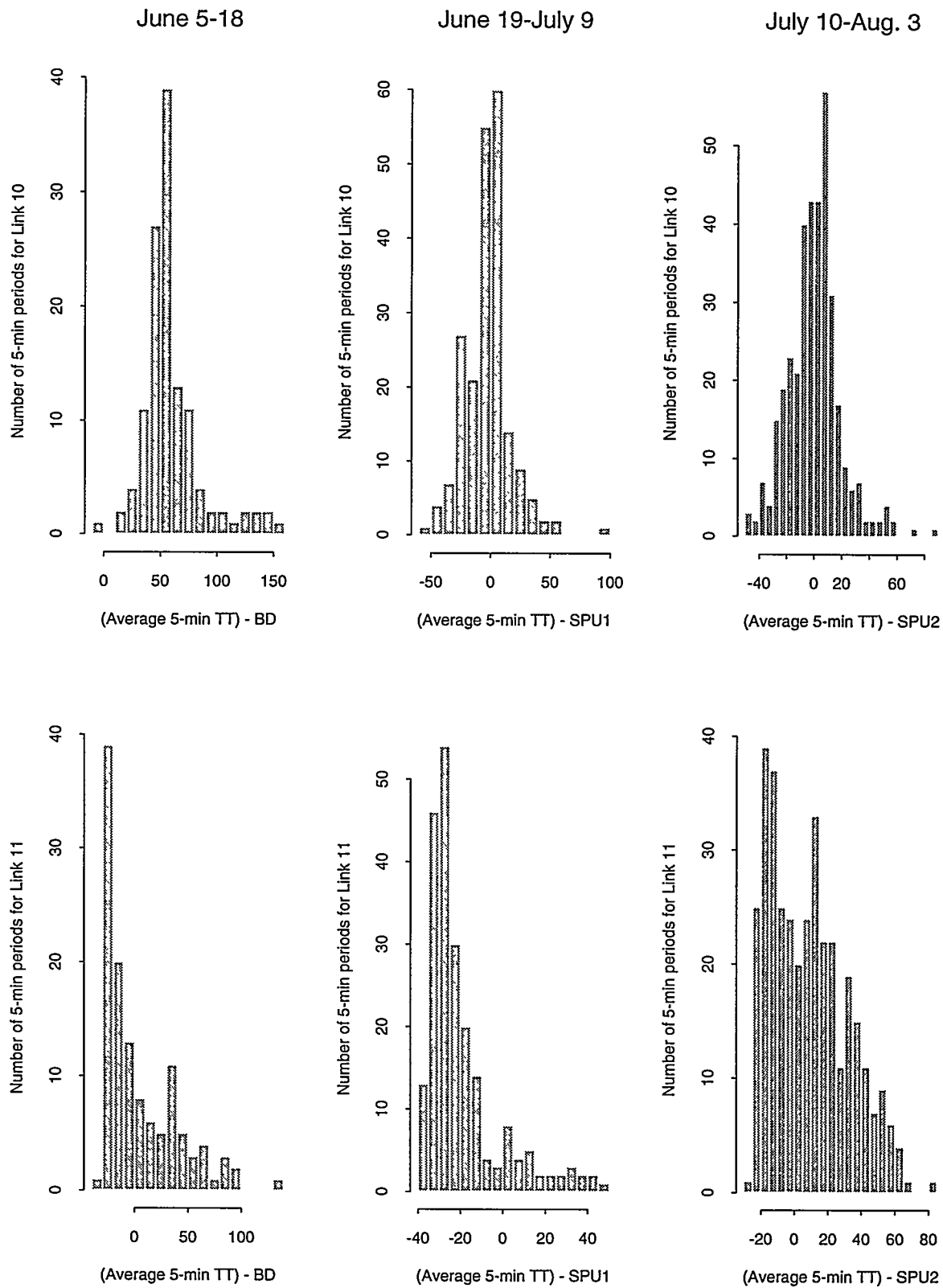

Figure 15: Difference between Average 5-minute Travel Time and BD, SPU1 and SPU2 Estimates (in seconds) by Number of 5-minute periods: Links 10 and 11

Table 23: SPU3 Travel Time Estimates (in seconds) Compared to Probe Travel Times: Off-Peak

| Link | SPU3 estimate | Mean Probe Travel Time | S. E. Probe T.T. | Difference probe T.T. - SP3 |
|------|---------------|------------------------|------------------|-----------------------------|
| 1 | 74.40 | 75.63 | 0.50 | 1.23 |
| 2 | 42.27 | 43.83 | 0.63 | 1.56 |
| 31 | 59.96 | 62.84 | 1.02 | 2.88 |
| 32 | 29.66 | 30.27 | 0.47 | 0.61 |
| 4 | 93.42 | 95.42 | 0.96 | 2.00 |
| 5 | 36.31 | 36.54 | 0.12 | 0.23 |
| 6 | 45.15 | 45.30 | 0.29 | 0.15 |
| 7 | 102.60 | 107.40 | 1.52 | 4.8 |
| 8 | 55.69 | 55.63 | 0.66 | -0.06 |
| 9 | 62.10 | 64.02 | 0.91 | 1.92 |
| 10 | 59.27 | 60.25 | 0.68 | 0.98 |
| 11 | 55.03 | 56.58 | 0.66 | 1.55 |
| 12 | 71.86 | 74.87 | 0.53 | 3.01 |

5.1.5 Hypothesis Test

Tables 23 and 24 present the SP3 estimates for each link in the peak and off-peak periods. Also shown are the average probe travel times for data collected throughout the study period (June 6—August 4), the standard error of these travel times, and the difference between SP3 estimates and probe travel times.

It is apparent from these tables that for most links during the off-peak period (Table 23), the difference between SP3 and probe means for the corresponding SP interval is 3 times the standard error (S.E.) or less. The only exceptions are Links 7 and 12. In the peak period (Table 24) exceptions are Links 1, 8 and 12. We know that the true value of the standard error of the mean is several times the calculated S.E. We also know that the SP3 estimates are random variables. Therefore, there is little reason to doubt the hypothesis that SP3 estimates and probe means have the same expected values; i.e., there is no cause to suspect that the SP3 estimates are biased.

The ETP stated there are two hypotheses to be tested. The first hypothesis is that the NFM consistently and accurately estimates travel times. The second hypothesis to be tested is that the SP consistently and accurately estimates travel times. A formal test of hypothesis, beyond what we have already stated would be difficult for a number of reasons. The SP3 estimates and the probe means being based partially on the same data are not independent, precluding the use of standard 2-sample tests. Moreover, the standard errors of probe means are underestimated by the SE's, as already stated. Nevertheless, we are convinced that any bias in SP estimates is effectively negligible.

Table 24: SPU3 Travel Time Estimates (in seconds) Compared to Probe Travel Times: Peak

| Link | SPU3 estimate | Mean Probe Travel Time | S. E. Probe T.T. | Difference probe T.T. - SP3 |
|------|---------------|------------------------|------------------|-----------------------------|
| 1 | 69.09 | 70.84 | 0.57 | 1.75 |
| 2 | 58.06 | 58.75 | 0.79 | 0.69 |
| 31 | 65.27 | 66.52 | 0.90 | 0.25 |
| 32 | 41.22 | 41.55 | 0.84 | 0.33 |
| 4 | 116.50 | 119.06 | 1.99 | 2.56 |
| 5 | 37.70 | 37.98 | 0.32 | 0.28 |
| 6 | 56.23 | 56.80 | 1.14 | 0.57 |
| 7 | 219.35 | 225.37 | 5.40 | 6.02 |
| 8 | 82.11 | 104.59 | 3.05 | 22.48 |
| 9 | 196.44 | 198.80 | 4.32 | 2.36 |
| 10 | 80.36 | 82.12 | 0.53 | 1.76 |
| 11 | 51.40 | 52.71 | 0.65 | 1.31 |
| 12 | 80.45 | 85.88 | 0.79 | 5.43 |

5.2 Updates 4 and 5: 10-Interval Schedule

The SPUs for the 10-interval schedule are shown in Tables 25 through 34. As with the 2-interval updates, these estimates are quite accurate. Note that these updates occurred on the basis of less data per time period, and in some cases very little data. While most estimates can be seen to be on target, others (e.g., Link 7 for SPU4 and SPU5 for the 3:10-4:00 time interval, Table 27) are not as accurate, although rarely are they completely off the mark.

A close examination of the conditions show that the quality of SP estimates suffers when the following two conditions are present:

- the mean for the *as designed* 10-interval schedule is markedly different from the static estimates for the first SP estimate for the time period containing the appropriate SP interval (recall that the first SP update was conducted only for the 2 intervals: 1-4 pm and 4-6pm), and
- the number of observations in the interval is relatively small.

These conditions give us a clue as to what causes the less accurate estimates. The larger intervals of the 2-interval schedule would generally have far larger numbers of observations than the smaller *as designed* intervals. Thus, the SPU algorithm ‘thinks’ that SP1 is based on more observations and consequently must be far more reliable than

the mean from the smaller interval, which is based on fewer observations. As a result, the algorithm places greater weight to SP1 values.

A solution to this problem would be to do the following: We should not mix static profile estimation for 2 intervals with those for larger numbers of intervals. That is, we should not start developing 10-interval estimates by first constructing 2-interval estimates. The 10-interval SPU's need to be constructed directly from the BD estimates in parallel with the 2-interval SPU's. This is illustrated in Figure 16 which shows an alternative schedule of SP Update time periods and intervals (compare with Figure 4). This shows that subsequent SP runs using the 10-interval schedule are always based on previous updates using the 10-interval schedule. Since the 10-interval estimates initially might not be too reliable owing to the paucity of data given the smaller interval size, we might prefer not to use them initially. As the 10-interval estimates improve over subsequent updates, we should then provide these to the MNA's and stop updating at the 2-interval level. We could, for example, use static profile 1A then move to the 10-interval schedule and profiles 2B and 3B.

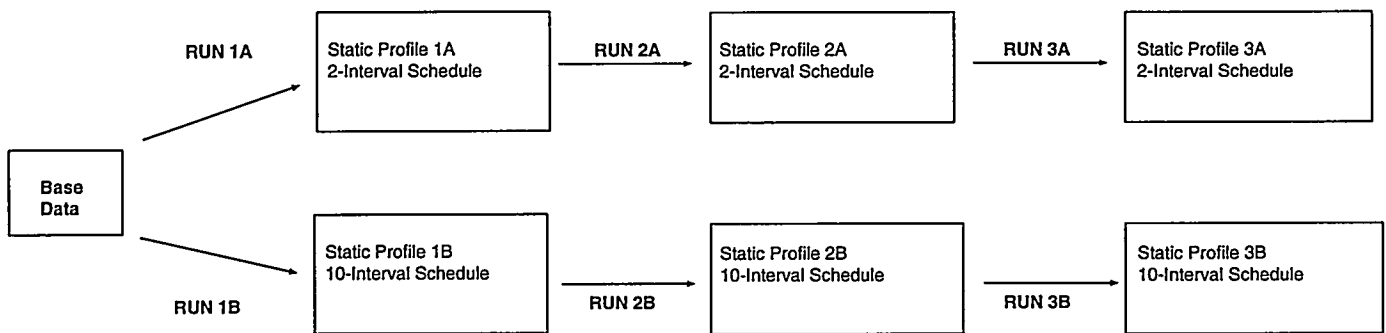

Figure 16: Alternative SP Update Time Periods and Interval Schedules

Table 25: Static Profile Travel Time Estimates (in seconds), 10-Interval Schedule: 1:00-2:30 pm

| Link | Probe (June 6 - July 23) | | | SPU4 | | SPU5 | |
|------|--------------------------|------|--------|-------|-------|-------|-------|
| | Mean | S.D. | Median | est | probe | est | probe |
| 1 | 74.4 | 21.2 | 73 | 68.89 | 72.8 | 73.54 | 79.3 |
| 2 | 42.6 | 28.7 | 31 | 46.11 | 44.8 | 42.22 | 40.2 |
| 31 | 61.3 | 32.6 | 53 | 57.68 | 59.3 | 56.96 | 57.3 |
| 32 | 30.5 | 16.6 | 25 | 29.73 | 31.8 | 29.77 | 29.9 |
| 4 | 92 | 31 | 83 | 89.39 | 92.7 | 90.37 | 92.0 |
| 5 | 36.5 | 3.7 | 37 | 36.01 | 36.6 | 36.21 | 36.5 |
| 6 | 45.3 | 10.3 | 43 | 44.86 | 45.6 | 44.95 | 45.2 |
| 7 | 98.4 | 40 | 104 | 95.49 | 99.8 | 97.43 | 100.7 |
| 8 | 53.6 | 16.8 | 49 | 54.63 | 53.7 | 54.67 | 54.9 |
| 9 | 58.3 | 17.4 | 55 | 59.88 | 60.9 | 57.23 | 56.7 |
| 10 | 54.8 | 31 | 37 | 57.72 | 58.9 | 55.16 | 51.5 |
| 11 | 60 | 28 | 68 | 54.79 | 58.6 | 55.76 | 56.8 |
| 12 | 75.9 | 20.1 | 72 | 70.89 | 78.2 | 71.33 | 71.8 |

Note: For Tables 25 to 32, the heading “Probe (June 6 - July 23)” refers to measures of location derived from data collected by probes over the period June 6-July 23, the heading “est” refers to the SPU estimate of mean travel time (in seconds), the heading “probe” refers to the average travel time (in seconds) for that link as determined from actual probe data gathered in that time period (see Table 4).

Table 26: Static Profile Travel Time Estimates (in seconds), 10-Interval Schedule: 2:30-3:10 pm

| Link | Probe (June 6 - July 23) | | | SPU4 | | SPU5 | |
|------|--------------------------|------|--------|-------|-------|-------|-------|
| | Mean | S.D. | Median | est | probe | est | probe |
| 1 | 72.3 | 21.6 | 70 | 65.88 | 68.9 | 69.8 | 79.2 |
| 2 | 42.3 | 28.7 | 31 | 45.03 | 41.2 | 43.8 | 41.9 |
| 31 | 70.9 | 31.9 | 68 | 59.07 | 68.5 | 59.71 | 62.8 |
| 32 | 28.9 | 14.2 | 25 | 27.93 | 29.9 | 28.02 | 28.1 |
| 4 | 100 | 35.6 | 90 | 90.36 | 104.1 | 91.99 | 96.2 |
| 5 | 36.4 | 3.4 | 35 | 35.35 | 36.0 | 35.86 | 36.8 |
| 6 | 45.5 | 8.2 | 43 | 44.55 | 45.3 | 45.02 | 45.9 |
| 7 | 109.4 | 58.1 | 105 | 91.66 | 93.2 | 96.48 | 125.6 |
| 8 | 55.4 | 16.8 | 52 | 55.74 | 55.3 | 55.86 | 56.1 |
| 9 | 62.6 | 24.6 | 58 | 61.43 | 67.5 | 59.62 | 59.1 |
| 10 | 62 | 31.7 | 58 | 59.0 | 66.3 | 59.32 | 60.0 |
| 11 | 52.4 | 26.8 | 35 | 51.76 | 52.6 | 51.67 | 51.7 |
| 12 | 76.2 | 26.4 | 69 | 68.84 | 83.9 | 69.25 | 70.2 |

Table 27: Static Profile Travel Time Estimates (in seconds), 10-Interval Schedule: 3:10-4:00 pm

| Link | Probe (June 6 - July 23) | | | SPU4 | | SPU5 | |
|------|--------------------------|------|--------|-------|-------|-------|-------|
| | Mean | S.D. | Median | est | probe | est | probe |
| 1 | 76.5 | 28.1 | 74.5 | 66.55 | 75.8 | 69.44 | 84.2 |
| 2 | 47.8 | 35.8 | 33 | 47.01 | 45.0 | 44.75 | 41.6 |
| 31 | 70.4 | 26.8 | 68 | 60.78 | 71.9 | 63.43 | 73.4 |
| 32 | 30.8 | 17.1 | 25 | 28.3 | 34.0 | 28.38 | 28.8 |
| 4 | 100.9 | 35 | 92 | 88.89 | 98.6 | 91.01 | 98.0 |
| 5 | 36.8 | 5.9 | 35 | 35.16 | 36.2 | 35.3 | 38.4 |
| 6 | 45.1 | 9.6 | 43 | 44.39 | 45.1 | 44.57 | 46.0 |
| 7 | 137.6 | 67.9 | 125 | 96.04 | 125.3 | 98.55 | 175.4 |
| 8 | 61.1 | 20.7 | 58 | 57.38 | 60.8 | 57.76 | 62.9 |
| 9 | 89.9 | 58.3 | 66 | 60.35 | 97.9 | 62.33 | 86.2 |
| 10 | 83.1 | 30.8 | 89 | 61.18 | 84.6 | 64.26 | 77.2 |
| 11 | 60.5 | 33.7 | 43 | 52.23 | 62.9 | 53.36 | 53.9 |
| 12 | 77.8 | 27.8 | 71 | 68.3 | 83.1 | 69.01 | 75.6 |

Table 28: Static Profile Travel Time Estimates (in seconds), 10-Interval Schedule: 4:00-4:40 pm

| Link | Probe (June 6 - July 23) | | | SPU4 | | SPU5 | |
|------|--------------------------|------|--------|-------|-------|-------|-------|
| | Mean | S.D. | Median | est | probe | est | probe |
| 1 | 70.6 | 23.7 | 62 | 65.18 | 68.1 | 67.45 | 75.9 |
| 2 | 58.9 | 27.9 | 60 | 57.97 | 60.0 | 57.54 | 56.0 |
| 31 | 65.6 | 30.8 | 52 | 63.27 | 68.1 | 64.95 | 70.2 |
| 32 | 41.2 | 19 | 31 | 37.34 | 38.5 | 39.88 | 42.4 |
| 4 | 122.4 | 47.9 | 109 | 107.3 | 118.2 | 114.7 | 126.1 |
| 5 | 37.7 | 5.4 | 37 | 36.61 | 37.6 | 37.46 | 37.9 |
| 6 | 48.8 | 14.7 | 44 | 48.45 | 47.9 | 49.12 | 49.5 |
| 7 | 166.9 | 89 | 139 | 145.9 | 140.9 | 162 | 181.5 |
| 8 | 91.2 | 47 | 77 | 71.53 | 70.4 | 75.55 | 100.6 |
| 9 | 162.1 | 93.1 | 173 | 140.6 | 101.5 | 155.4 | 191.6 |
| 10 | 77.7 | 27.3 | 79 | 78.73 | 73.2 | 78.28 | 77.4 |
| 11 | 49.5 | 27 | 39 | 52.54 | 42.7 | 53.72 | 58.3 |
| 12 | 83.1 | 26.3 | 79 | 79.24 | 89.8 | 76.81 | 72.6 |

Table 29: Static Profile Travel Time Estimates (in seconds), 10-Interval Schedule: 4:40-5:10 pm

| Link | Probe (June 6 - July 23) | | | SPU4 | | SPU5 | |
|------|--------------------------|-------|--------|-------|-------|-------|-------|
| | Mean | S.D. | Median | est | probe | est | probe |
| 1 | 70.5 | 23.5 | 64 | 65.77 | 69.8 | 67.38 | 71.6 |
| 2 | 61.9 | 45.2 | 66 | 57.97 | 60.1 | 58.02 | 58.8 |
| 31 | 63.9 | 30.5 | 49 | 62.68 | 65.1 | 63.5 | 69.6 |
| 32 | 40.9 | 18.4 | 35.5 | 36.83 | 37.5 | 39.56 | 43.1 |
| 4 | 112.1 | 43.5 | 93 | 105.5 | 114.8 | 107.6 | 110.8 |
| 5 | 37.1 | 4.4 | 37 | 36.34 | 36.5 | 36.82 | 37.4 |
| 6 | 49.8 | 14.5 | 45.5 | 51.55 | 50.7 | 51.14 | 49.5 |
| 7 | 187.3 | 75.9 | 179 | 167.1 | 163.4 | 183.4 | 201.7 |
| 8 | 99.9 | 70.9 | 80.5 | 75.57 | 74.1 | 77.34 | 112.3 |
| 9 | 187.5 | 118.1 | 187 | 187.5 | 124.9 | 194.7 | 216.3 |
| 10 | 83 | 25.3 | 81.5 | 81.54 | 81.2 | 81.21 | 80.8 |
| 11 | 48.5 | 27.7 | 37 | 53.26 | 42.1 | 53.91 | 57.4 |
| 12 | 90.8 | 52.8 | 85 | 76.59 | 99.4 | 78.16 | 81.1 |

Table 30: Static Profile Travel Time Estimates (in seconds), 10-Interval Schedule: 5:10-5:30 pm

| Link | Probe (June 6 - July 23) | | | SPU4 | | SPU5 | |
|------|--------------------------|-------|--------|-------|-------|-------|-------|
| | Mean | S.D. | Median | est | probe | est | probe |
| 1 | 68.9 | 23 | 62 | 64.99 | 68.2 | 65.71 | 70.0 |
| 2 | 61 | 29.7 | 70 | 57.29 | 57.3 | 57.34 | 57.9 |
| 31 | 65.4 | 34.4 | 52 | 61.94 | 62.9 | 61.46 | 59.7 |
| 32 | 43.4 | 18.1 | 44.5 | 39.82 | 44.9 | 41.03 | 42.3 |
| 4 | 120 | 46.4 | 112 | 401.3 | 129.8 | 108.2 | 115.2 |
| 5 | 39.8 | 11.7 | 37 | 36.54 | 40.4 | 37.8 | 39.4 |
| 6 | 68.8 | 26.5 | 63 | 59.52 | 65.2 | 64.65 | 70.5 |
| 7 | 309.7 | 94 | 315 | 265.1 | 281.5 | 289.5 | 321.2 |
| 8 | 138.2 | 111.1 | 88 | 75.91 | 72.2 | 79.43 | 167.2 |
| 9 | 266.7 | 102.8 | 248 | 238.6 | 247.1 | 245.7 | 279.0 |
| 10 | 85.5 | 23.5 | 85 | 82.82 | 84.3 | 82.78 | 82.7 |
| 11 | 54.3 | 27.8 | 43 | 60.97 | 49.7 | 60.48 | 58.0 |
| 12 | 93.4 | 27.5 | 89 | 79.02 | 100.6 | 80.47 | 86.5 |

Table 31: Static Profile Travel Time Estimates (in seconds), 10-Interval Schedule: 5:30-5:40 pm

| Link | Probe (June 6 - July 23) | | | SPU4 | | SPU5 | |
|------|--------------------------|-------|--------|-------|-------|--------|-------|
| | Mean | S.D. | Median | est | probe | est | probe |
| 1 | 66.9 | 21.6 | 60 | 64.52 | 67.3 | 64.83 | 65.9 |
| 2 | 61.9 | 28.3 | 70.5 | 57.38 | 58.6 | 57.53 | 60.4 |
| 31 | 69.8 | 37 | 52 | 61.75 | 62.1 | 63.63 | 78.7 |
| 32 | 37.4 | 18.3 | 27.5 | 37.02 | 42.4 | 37.11 | 36.9 |
| 4 | 137.4 | 53.6 | 139 | 98.83 | 120.5 | 107.9 | 148.8 |
| 5 | 40.4 | 16 | 37 | 36.44 | 36.7 | 36.66 | 42.5 |
| 6 | 86.9 | 50.7 | 74 | 64.54 | 72.9 | 72.28 | 94.6 |
| 7 | 350.9 | 166.3 | 352 | 227.3 | 285.5 | 267.4 | 402.2 |
| 8 | 105.5 | 55.1 | 82 | 76.14 | 72.1 | 79.69 | 116.8 |
| 9 | 245.4 | 78 | 249.5 | 243.8 | 257.7 | 242.96 | 235.8 |
| 10 | 84.9 | 27.3 | 81 | 82.84 | 88.5 | 82.64 | 81.7 |
| 11 | 50.6 | 25.6 | 43 | 61.63 | 49.1 | 60.99 | 55.4 |
| 12 | 93.4 | 29.1 | 94 | 76.74 | 95.6 | 78.32 | 88.7 |

Table 32: Static Profile Travel Time Estimates (in seconds), 10-Interval Schedule: 5:40-6:00 pm

| Link | Probe (June 6 - July 23) | | | SPU4 | | SPU5 | |
|------|--------------------------|-------|--------|--------|-------|-------|-------|
| | Mean | S.D. | Median | est | probe | est | probe |
| 1 | 68.6 | 24.1 | 61 | 65.13 | 70.2 | 66.59 | 71.2 |
| 2 | 58.3 | 27.6 | 64 | 57.77 | 60.4 | 56.96 | 51.6 |
| 31 | 64 | 37.6 | 51 | 62.41 | 67.9 | 61.93 | 61.4 |
| 32 | 43.2 | 23.3 | 38 | 38.23 | 44.0 | 40.4 | 42.3 |
| 4 | 114.7 | 46.7 | 93 | 102.5 | 110.9 | 106.2 | 118.5 |
| 5 | 37.2 | 3.4 | 37 | 36.54 | 36.8 | 36.92 | 37.5 |
| 6 | 59.1 | 28.9 | 45 | 53.51 | 55.7 | 55.64 | 62.6 |
| 7 | 308.9 | 134.5 | 323 | 261.6 | 281.1 | 279.4 | 323.7 |
| 8 | 113.4 | 79 | 78.5 | 100.1 | 93.4 | 105.5 | 121.7 |
| 9 | 223.1 | 97.8 | 206 | 231.76 | 231.8 | 225.6 | 215.4 |
| 10 | 81 | 22.1 | 82 | 81.55 | 80.8 | 81.79 | 82.9 |
| 11 | 52.4 | 31.7 | 39 | 57.7 | 44.1 | 56.66 | 52.4 |
| 12 | 83.9 | 22.8 | 83 | 77.84 | 86.2 | 78.29 | 80.0 |

Table 33: Static Profile Travel Time Estimates (in seconds), 10-Interval Schedule: 6:00-6:45 pm

| Link | Probe (June 6 - July 23) | | | SPU4 | | SPU5 | |
|------|--------------------------|-------|--------|-------|-------|-------|-------|
| | Mean | S.D. | Median | est | probe | est | probe |
| 1 | 67.9 | 21.9 | 60 | 64.63 | 66.8 | 66.57 | 71.3 |
| 2 | 54 | 28.2 | 47 | 46.10 | 56.2 | 47.07 | 50.4 |
| 31 | 62.8 | 30.5 | 52 | 60.43 | 63.0 | 60.46 | 61.3 |
| 32 | 35.2 | 15.1 | 29 | 32.07 | 32.8 | 33.23 | 37.5 |
| 4 | 100.7 | 32.9 | 92 | 84.07 | 100.9 | 87.05 | 103.0 |
| 5 | 38.1 | 10 | 37 | 35.62 | 39.1 | 35.99 | 36.6 |
| 6 | 50 | 22.3 | 43 | 43.91 | 44.6 | 44.42 | 53.2 |
| 7 | 148.2 | 107.7 | 120 | 71.18 | 114.2 | 76.16 | 176.6 |
| 8 | 83.5 | 41.8 | 74.5 | 65.79 | 73.5 | 67.59 | 88.0 |
| 9 | 115.6 | 82.3 | 72.5 | 67.35 | 105.9 | 72.47 | 115.1 |
| 10 | 70.8 | 28.1 | 71.5 | 72.18 | 65.5 | 69.42 | 64.2 |
| 11 | 42.1 | 23.3 | 33 | 38.6 | 36.0 | 40.05 | 46.7 |
| 12 | 75.8 | 19.8 | 73 | 71.16 | 76.0 | 71.89 | 74.0 |

Table 34: Static Profile Travel Time Estimates (in seconds), 10-Interval Schedule: 6:45-7:00 pm

| Link | Probe (June 6 - July 23) | | | SPU4 | | SPU5 | |
|------|--------------------------|------|--------|-------|-------|-------|-------|
| | Mean | S.D. | Median | est | probe | est | probe |
| 1 | 64.2 | 22.5 | 56 | 62.71 | 61.1 | 63.37 | 65.3 |
| 2 | 51.2 | 25 | 47 | 45.2 | 55.0 | 45.95 | 48.7 |
| 31 | 52.5 | 32.6 | 41 | 57.74 | 50.0 | 56.9 | 53.9 |
| 32 | 34.5 | 18.2 | 28 | 32.84 | 36.4 | 33.12 | 33.5 |
| 4 | 87.1 | 23.8 | 84 | 81.77 | 89.1 | 83.77 | 90.5 |
| 5 | 36.1 | 4 | 35 | 35.43 | 35.9 | 35.59 | 36.0 |
| 6 | 42.8 | 8.6 | 41 | 45.32 | 42.9 | 43.42 | 43.7 |
| 7 | 82.9 | 39.4 | 76 | 68.02 | 79.1 | 72.4 | 93.1 |
| 8 | 67.7 | 16.9 | 70 | 64.29 | 67.4 | 67.3 | 71.1 |
| 9 | 66.4 | 39 | 54 | 65.3 | 74.0 | 66.2 | 69.8 |
| 10 | 52.2 | 32.2 | 41 | 73.8 | 61.2 | 69.56 | 54.2 |
| 11 | 41.2 | 24.2 | 33 | 36.49 | 34.1 | 37.33 | 45.7 |
| 12 | 72.8 | 17.3 | 71 | 69.26 | 69.9 | 69.94 | 72.4 |

5.2.1 Evaluation of SPU4 Estimates as Forecasts

Since there are only two SPUs with the 10-interval data there can be only one check of its performance, namely the driving experience after SPU4. Figure 17 illustrates the differences between SPU4 and the average 5-minute travel times during respective intervals. To make the figure manageable we have selected three links (Links 2, 10 and 11) and four of the ten time intervals. Two of the intervals are during the off-peak and two are for the peak period.

With the zero level on the horizontal axis marking correspondence between SPU and average travel time, this level seems to well describe the central point of most distributions. Note that even for the ten-minute interval (5:30-5:40 pm) where we have fewer observations than for the other time intervals the zero level describes the data relatively well. Again the SPUs act as very good predictors of travel time.

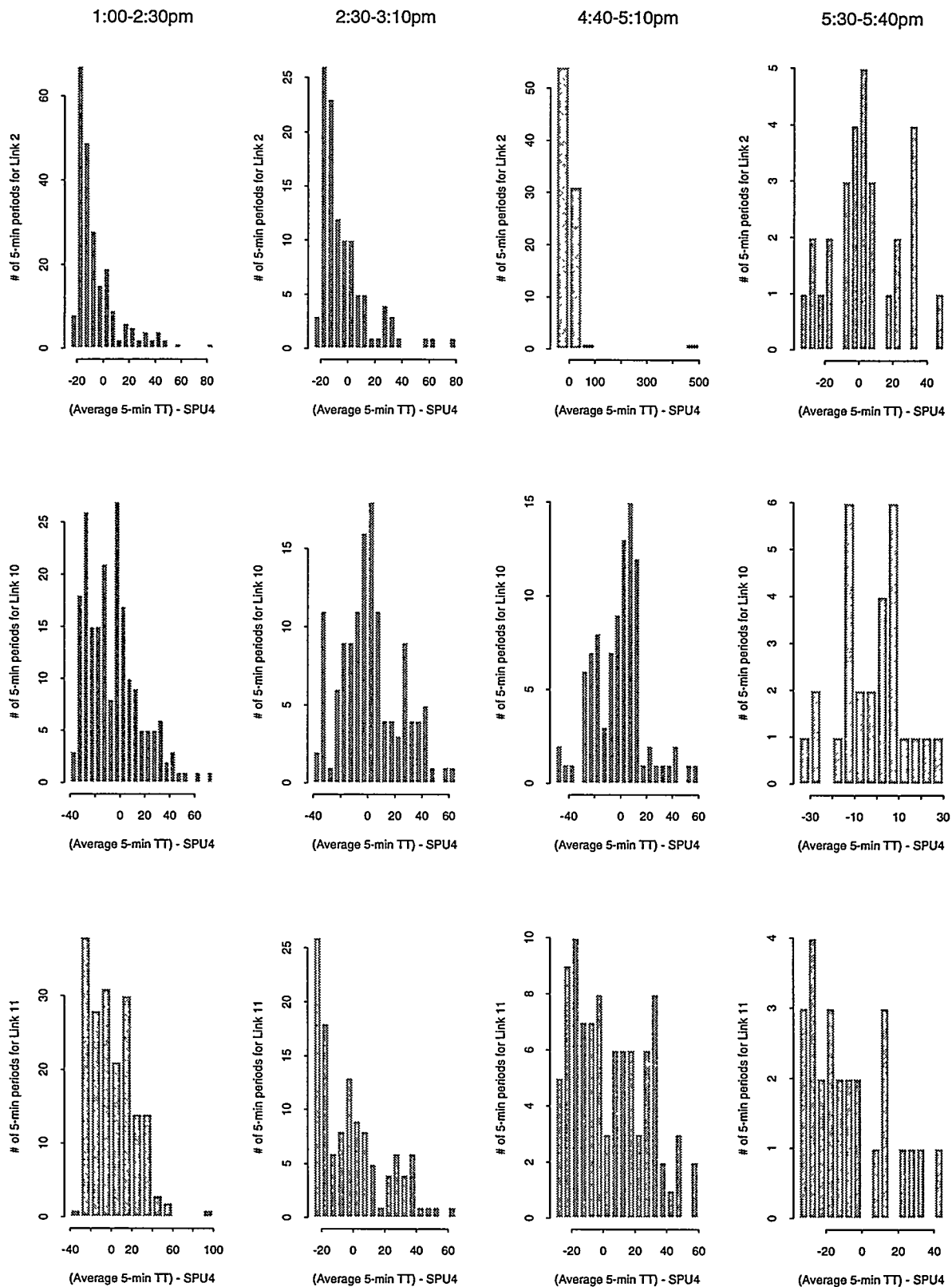

Figure 17: Average 5-minute Travel Time (in seconds) by Number of 5-minute periods, Links 2, 10 and 11: SPU4

6 SPU Results - Fused Data

The SPU runs were performed using fused data, that is, data received both from probe data and from inductive loop detectors in the road. For details of the data fusion process see ADVANCE Report No. 48.

6.1 2-Interval Schedule: Static Profile Updates 1, 2 and 3

The output from SPU runs using fused data are given in Tables 35, 36 and 37 for SPU runs 1, 2 and 3. Comparing these results with Tables 21 and 22, it may be observed that SP estimates of travel time based on fused data are quite accurate but are not as good as those estimates based on probe data alone. The additional data from detectors appears to adversely affect the estimates. This observation leads to the conjecture that data fusion may not be yielding accurate estimates, itself a subject which could be investigated in a later report.

For SPU 1 the initial estimate of travel time is the BD estimate; for SPU 2 the initial estimate is the output of SPU 1; for SPU 3 the initial estimate is the output of SPU 2 (see Figure 4).

Table 35: SPU 1 Travel Time Estimates (in seconds) for Links 1, 7 and 11 using Fused Data

| Time | Link 1 | | Link 7 | | Link 11 | |
|-------------|------------------|-------|------------------|--------|------------------|-------|
| | Initial estimate | SPU1 | Initial estimate | SPU1 | Initial estimate | SPU1 |
| 13:00-16:00 | 56.00 | 66.72 | 84.90 | 91.28 | 39.41 | 48.72 |
| 16:00-18:00 | 54.00 | 64.96 | 55.94 | 103.40 | 70.36 | 63.76 |
| 18:00-24:00 | 52.96 | 63.47 | 43.94 | 75.73 | 31.70 | 43.01 |

Table 36: SPU 2 Travel Time Estimates (in seconds) for Links 1, 7 and 11 using Fused Data

| Time | Link 1 | | Link 7 | | Link 11 | |
|-------------|------------------|-------|------------------|--------|------------------|-------|
| | Initial estimate | SPU2 | Initial estimate | SPU2 | Initial estimate | SPU2 |
| 13:00-16:00 | 66.72 | 72.29 | 91.28 | 96.91 | 48.72 | 51.48 |
| 16:00-18:00 | 64.96 | 67.68 | 103.40 | 134.52 | 63.76 | 48.30 |
| 18:00-24:00 | 63.47 | 63.77 | 75.73 | 76.04 | 43.01 | 38.54 |

Table 37: SPU 3 Travel Time Estimates (in seconds) for Links 1, 7 and 11 using Fused Data

| Time | Link 1 | | Link 7 | | Link 11 | |
|-------------|------------------|-------|------------------|--------|------------------|-------|
| | Initial estimate | SPU3 | Initial estimate | SPU3 | Initial estimate | SPU3 |
| 13:00-16:00 | 72.29 | 76.99 | 96.91 | 100.57 | 51.48 | 51.05 |
| 16:00-18:00 | 67.68 | 69.83 | 134.52 | 148.69 | 48.30 | 49.88 |
| 18:00-24:00 | 63.77 | 65.69 | 76.04 | 76.25 | 38.54 | 40.11 |

6.2 10-Interval Schedule: Static Profile Updates 4 and 5

The output from SPU runs using fused data are given in Tables 38, and 39 for SPU runs 4 and 5. The conclusion that fused data appears to be giving us less accurate travel time estimates than those developed from probe data alone, also appears to hold true for these runs.

For SPU 4 the initial estimate is the output of SPU 1; for SPU 5 the initial estimate is the output of SPU 4 (see Figure 4).

Table 38: SPU 4 Travel Time Estimates (in seconds) for Links 1, 7 and 11 using Fused Data

| Time | Link 1 | | Link 7 | | Link 11 | |
|-------------|------------------|-------|------------------|--------|------------------|-------|
| | Initial estimate | SPU4 | Initial estimate | SPU4 | Initial estimate | SPU4 |
| 13:00-14:30 | 66.72 | 71.51 | 91.28 | 94.26 | 48.72 | 51.17 |
| 14:30-15:10 | 66.72 | 68.87 | 91.28 | 92.00 | 48.72 | 49.09 |
| 15:10-16:00 | 66.72 | 69.67 | 91.28 | 96.14 | 48.72 | 50.38 |
| 16:00-16:40 | 64.96 | 66.33 | 103.40 | 117.38 | 63.76 | 50.84 |
| 16:40-17:10 | 64.96 | 66.48 | 103.40 | 121.98 | 63.76 | 52.14 |
| 17:10-17:30 | 64.96 | 65.95 | 103.40 | 117.96 | 63.76 | 58.85 |
| 17:30-17:40 | 64.96 | 65.36 | 103.40 | 107.72 | 63.76 | 60.05 |
| 17:40-18:00 | 64.96 | 65.94 | 103.40 | 116.92 | 63.76 | 55.69 |
| 18:00-18:45 | 63.47 | 64.90 | 75.73 | 75.88 | 43.01 | 39.60 |
| 18:45-19:00 | 63.47 | 63.18 | 75.73 | 75.78 | 43.01 | 37.55 |
| 19:00-24:00 | 63.47 | 62.67 | 75.73 | 75.86 | 43.01 | 39.78 |

Table 39: SPU 5 Travel Time Estimates (in seconds) for Links 1, 7 and 11 using Fused Data

| Time | Link 1 | | Link 7 | | Link 11 | |
|-------------|------------------|-------|------------------|--------|------------------|-------|
| | Initial estimate | SPU5 | Initial estimate | SPU5 | Initial estimate | SPU5 |
| 13:00-14:30 | 71.51 | 76.34 | 94.26 | 96.08 | 51.17 | 51.48 |
| 14:30-15:10 | 68.87 | 72.17 | 92.00 | 94.95 | 49.09 | 49.09 |
| 15:10-16:00 | 69.67 | 75.82 | 96.14 | 99.37 | 50.38 | 50.13 |
| 16:00-16:40 | 66.33 | 68.45 | 117.38 | 126.23 | 50.84 | 51.55 |
| 16:40-17:10 | 66.48 | 68.17 | 121.98 | 132.71 | 52.14 | 52.37 |
| 17:10-17:30 | 65.95 | 67.66 | 117.96 | 131.00 | 58.85 | 57.90 |
| 17:30-17:40 | 65.36 | 66.07 | 107.72 | 112.08 | 60.05 | 58.89 |
| 17:40-18:00 | 65.94 | 67.65 | 116.92 | 127.13 | 55.69 | 54.47 |
| 18:00-18:45 | 64.90 | 67.02 | 75.88 | 75.96 | 39.60 | 41.01 |
| 18:45-19:00 | 63.18 | 64.05 | 75.78 | 75.86 | 37.55 | 38.32 |
| 19:00-24:00 | 62.67 | 63.81 | 75.86 | 76.02 | 39.78 | 40.57 |

7 Conclusions.

The SPU algorithm on the whole yields very good estimates. Even if initial BD estimates are inaccurate, SPU very quickly adjusts the values to acceptable levels.

However, we present the following suggestions for improvement if a procedure like SPU is implemented in the future:

- Arrangements should be made to get information on changes in traffic signal timings and other similar changes and the SPU algorithm should be capable of adjusting estimates accordingly.
- The SPU algorithm should be capable of detecting dramatic changes in travel times and be able to take appropriate action. While such a capability was designed, the design should be revisited in the light of some of the results from this evaluation.
- While not identified as a part of the current effort, there has been some concern over Static Profile Updates being step functions. Perhaps we should consider constructing continuous SP Updates. A piecewise linear SPU might not require additional space on the storage media. Instead of interval end-points and value, we would need to store interval end-points and slope. However, new procedures might have to be developed to construct estimates.
- If a large number of SPU intervals (such as our 10-interval schedule) is used, the updating process for it should start right at the beginning of the data collection,

although we might supply only estimates for a smaller number of intervals to the on-board real-time route guidance system.

- When adequate probe data are available, little is to be gained by supplementing them with detector data.

While these suggestions could improve the SPU procedures, we reiterate that even as implemented they work very well, particularly those using probe data only.

References

ADVANCE Working Paper No. 41, *Creation of the ADVANCE Network Attribute Database*, A. Tarko, S. Berka, and F. Xu, Urban Transportation Center, University of Illinois, Chicago, September 1994.

ADVANCE Working Paper No. 43, *Trip Data Factoring for the ADVANCE Network Flow Model*, Y. Zhang, J. Hicks, and D.E. Boyce, Urban Transportation Center, University of Illinois, Chicago, December 1994.

ADVANCE Working Paper No. 48, *Data Fusion Algorithm for ADVANCE Release 2.0*, S. Berka, X. Tian and A. Tarko, Urban Transportation Center, University of Illinois, Chicago, May 1995.

ADVANCE Working Paper No. 49, *Static Estimates of Travel Times in ADVANCE Release 2.0 SPU Algorithm Report and Detailed Design Document (#8600)*, M. Mathes and A. Sen, Urban Transportation Center, University of Illinois, Chicago, July 1995.

S. Berka, D.E. Boyce, J. Raj, B. Ran, A. Tarko, and Y. Zhang, *A Large-Scale Route Choice Model with Realistic Link Delay Functions for Generating Highway Travel Times*, Technical Report, IDOT, 1994.

Evaluation Test Plan: *Base Data and Static Profile*, Urban Transportation Center, University of Illinois, Chicago, July 1995.

Glossary

ANOVA - Analysis of Variance, a standard statistical procedure

Attribute Database - a database containing updatable information necessary for on-line data fusion, travel time prediction and incident detection. Attributes include link length, traffic control type.

Base Data (BD)/Base Data Estimates - travel time predictions for specific links at specific times as derived from the NFM.

Chicago Area Transportation Study (CATS) - The electronic network description file supplied by CATS. The file is used by the TRF group along with the MIF file from Motorola to build the ANR file.

Cruise Time - the time it would take a vehicle to traverse a link, in the absence of congestion, at a constant speed, usually the posted speed limit + 5 mph

Interval - see **SP Interval** and **Updating Interval**.

Mobile Navigation Assistant (MNA) - An in-vehicle navigation system designed and built by Motorola that determines vehicle position, performs route planning based on current traffic information, and provides dynamic route guidance information to the driver.

Network Flow Model (NFM) - the model developed by the TRF group based upon the contents of the *ADVANCE* Network Representation (ANR). The network flow model analyzes the ANR to produce link travel times and link flows by time period and day type.

Off-Peak - that portion of the day considered to have lighter traffic flow, defined in the experiment as 1pm-4pm. The 2-interval schedule considers this period as one interval, the 10-interval schedule as three intervals.

Peak - that portion of the day considered to have heavier traffic flow, defined in the study as 4pm-6pm. The 2-interval schedule considers this period as one interval, the 10-interval schedule as five intervals.

Run - one operation of the SPU process, using the field data and the previous SP as processed by the SPU algorithm.

Schedule - division of the time period (1pm-7pm) under consideration by the SPU, consisting of either two or ten intervals.

Static Profile (SP) - static information of the roadway link including day type, link ID and average travel times for a specific time period.

SP Interval - variable-length time period, as determined by the interval schedule, for which average travel times are determined by the SPU. Intervals can range from as long

as several hours to as short as 10 minutes depending on the interval schedule.

Static Profile Updating (SPU) - the revision of previous Static Profile travel times for links, during specific time periods, using information gathered from probe reports and processed through the SP algorithm.

Traffic Information Center (TIC) - Consisting of the hardware, software, a centralized facility and operations personnel. It communicates to and from probes and external systems.

Traffic Related Functions (TRF) - Subsystem consisting of data fusion, vehicle dynamics, incident detection and travel time prediction algorithms.

Updating Interval - the period of days or weeks of probe data collection for which SP updates are revised, also referred to as updating time periods.

APPENDIX B

ADVANCE

**Advanced Driver and Vehicle
Advisory Navigation Concept**

Traffic Related Functions
Evaluation Report (2 of 7)
Documents # 8460.00

CONTAINS:

| | |
|--|--------------------------|
| Base Data and Static Profile Evaluation Report | -- Document # 8460-01.00 |
| • Data Screening Evaluation Report | -- Document # 8460-02.02 |
| Quality of Probe Reports Evaluation Report | -- Document # 8460-03.01 |
| Travel Time Prediction and Performance of Probe and Detector Data Evaluation Report | -- Document # 8460-04.00 |
| Detector Travel Time Conversion and Fusion of Probe and Detector Data Evaluation Report | -- Document # 8460-05.00 |
| Frequency of Probe Reports Evaluation Report | -- Document # 8460-06.00 |
| Relationships among Travel Times Evaluation Report | -- Document # 8460-07.02 |

Prepared by
University of Illinois-Chicago
Urban Transportation Center

DISCLAIMER

This report was prepared by a contractor for
Argonne National Laboratory
and is published as it was received.

ADVANCE Evaluation

Data Screening

Stanislaw Berka, Aaron Sheffey, and Ashish Sen

URBAN TRANSPORTATION CENTER
University of Illinois at Chicago
1033 West Van Buren Street
Suite 700 South
Chicago, Illinois 60607

March, 1996

Executive Summary

A key component of the Traffic Related Functions (TRF) subsystem of the ADVANCE Project is Data Screening (DS). Evaluating travel time and congested-distance data collected from probe (vehicle) reports, as well as in-pavement loop detector reports which contain volume and occupancy data, DS identifies potentially incorrect information. The DS module evaluates both sets of data by assessing the reasonableness of each then processing the overall consistency of the information within the set. This process determines the accuracy of the information gathered from the probe and detector reports. If the information is deemed to be inconsistent or incorrect, it is removed from the data set.

The DS algorithm was first tested using simulated data. For both probe and detector data, limits for given links and time periods were constructed. Three test figures, two of which were designed to be flagged by DS and one meant to pass DS, were then run through the algorithm. The results of these tests were then evaluated to see whether those simulated reports designed to be eliminated by the DS algorithm were in fact flagged, and whether those designed to pass, actually did. For the simulated data, the DS algorithm performed as designed.

The results of using actual field data were cross-checked against manually-recorded measurements and recorded incident data. DS for actual data led to an overall probe data consistency success rate of greater than 99% and a 92% success rate for detector data consistency. Probe data reports which failed DS without providing an incident flag indicated some potential inconsistencies in the MNA's formulation of the original data set. It was concluded that the DS algorithm was effective in identifying rare occasions when MNA's malfunctioned and its use should be continued.

Contents

| | |
|--|----|
| Executive Summary | i |
| 1 Introduction | 1 |
| 2 Evaluation Procedure | 2 |
| 2.1 Overview | 2 |
| 2.2 Verification of Attribute Database | 3 |
| 2.3 Evaluation Using Simulated Data | 3 |
| 2.4 Evaluation Using Actual Data | 5 |
| 2.5 Analysis of Failed Reports | 5 |
| 2.6 Analysis of Passed Reports | 6 |
| 3 Simulated Data Generation, Processing and Analysis | 6 |
| 4 Actual Data Generation, Processing, and Analysis | 7 |
| 5 Results | 8 |
| 5.1 Simulated Data | 8 |
| 5.2 Actual Probe Data | 8 |
| 5.3 Actual Detector Data | 9 |
| 6 Conclusions | 10 |

1 Introduction

Data screening is part of the Data Fusion subcomponent of the Traffic Related Functions of the ADVANCE system and runs on-line on the TIC computer. It is performed to identify those probe and detector reports which appear to correspond to unusual traffic conditions or probe reporting errors. Identified reports which could have an adverse effect on the results of travel time predictions are marked. Two phases of data screening are distinguished:

1. reasonableness for a single datum and
2. consistency checking of a pair of data.

As evaluated in data screening, all data reports consist of two data items. In the case of probe reports, these items are travel time (t_p) and congested distance (l_c). In the case of detector reports, these items are volume (v) and occupancy (o). Each report is tested for the reasonableness of each datum, and for the mutual consistency of a pair of data.

Datum x , which is a measurement of travel time, congested distance, volume, or occupancy for a given link at a certain time (see Section 2.3), is considered reasonable if it meets the following condition:

$$x_{min} \leq x \leq x_{max}, \quad (1)$$

where x_{min} and x_{max} are appropriate cut-offs. For example, for a signalized link, the travel time t_p passes the reasonableness test if it fulfills the following condition:

$$\frac{l}{f_v \cdot v_m} \leq t_p \leq \frac{3600 \cdot l}{l_Q \cdot S \cdot (\frac{g}{c})_{min}} + r_{max}. \quad (2)$$

[Note: To avoid duplication, not all tests used in data screening will be cited here. Comprehensive descriptions can be found in Berka, Tian, and Tarko (1995), which is available on the web (<http://beijing.dis.anl.gov/ADVANCE>).] Symbols in the above expression denote fixed parameters defined by the data screening algorithm and are defined as follows:

| | | |
|-----------------------|---|---|
| f_v | = | adjustment factor for random variations of travel speed |
| $(\frac{g}{c})_{min}$ | = | Minimum green-to-cycle ratio (-) |
| l | = | length of a base segment (m) |
| l_Q | = | effective length of vehicle in queue (m) |
| r_{max} | = | maximum length of red signal (sec) |
| S | = | saturation flow, which is lane capacity if entire signal cycle is effectively green (veh/h) |
| t_p | = | individual probe travel time along a link (sec) |
| v_m | = | posted speed limit (m/s). |

A pair of data (x, y) is considered consistent if it meets the following condition:

$$y_{min}(x) \leq y \leq y_{max}(x). \quad (3)$$

Where $y_{min}(x)$ and $y_{max}(x)$ depend on characteristic x . For example, for a signalized link, the travel time t_p is considered to be consistent with congested distance l_c if it meets the following condition:

$$\frac{l}{t_p} \geq \frac{l}{a_{L1} \cdot \frac{N_l \cdot l_c}{C_{lg}} + a_{L2} \cdot \frac{l - l_c}{v_m} + a_{L3} \cdot (c - g)} - k_a \cdot \sigma_{aL} \quad (4)$$

and

$$\frac{l}{t_p} \leq \frac{l}{a_{L1} \cdot \frac{N_l \cdot l_c}{C_{lg}} + a_{L2} \cdot \frac{l - l_c}{v_m} + a_{L3} \cdot (c - g)} + k_a \cdot \sigma_{aL}, \quad (5)$$

where

- a_{L1} = parameter (= 470) in the probe report consistency relationship for an arterial link outflow controlled with a traffic signal
- a_{L2} = parameter (= 1.3) in the probe report consistency relationship for an arterial link outflow controlled with a traffic signal
- a_{L3} = parameter (= 0.5) in the probe report consistency relationship for an arterial link outflow controlled with a traffic signal
- c = signal cycle (sec)
- C_{lg} = lane group capacity (veh/hr)
- g = green signal (sec)
- k_a = standard deviation multiplier (= 3) for arterial probe data relationship (-)
- l = length of a base segment (meter)
- l_c = congested distance which is the distance traversed at a speed below the critical value (meter)
- N_l = number of lanes in a group (-)
- t_p = individual probe travel time along a link (sec)
- σ_{aL} = standard deviation for probe report consistency relationship and link with an outflow controlled with a traffic signal (meter/sec).

Notice that unlike the single datum case, the cut-offs are based on reported data. The description of the data screening algorithm can be found in Berka, Tian and Tarko (1995) and the calibrated parameters in Berka and Tian (1995).

2 Evaluation Procedure

2.1 Overview

The evaluation procedure consists of several steps. First, the attribute database, needed in subsequent steps, is checked to make sure it contains all necessary information. Second, an evaluation using simulated data is performed to determine the veracity of

the implementation. Third, an evaluation using actual field data is done. Fourth, an analysis of both the reports which pass data screening, as well as those which fail data screening, is performed.

2.2 Verification of Attribute Database

The Attribute Database contains data elements required by the data screening algorithm. It includes elements of the ANR (ADVANCE Network Representation), an ASCII file which combines information from the CATS file, field observer logs, and the Motorola Interchange File (MIF) file to describe a given ADVANCE test area. This information contains traffic related characteristics of the transportation network, including approach geometry, speed limits, and type of control. All flow characteristics (volume, capacity, green times, and cycles) are derived from NFM (Network Flow Model) results.

2.3 Evaluation Using Simulated Data

Actual parameters of the TRF-DF algorithm were obtained from TIC. Representative links for specific categories, such as those comprising four-way stops and left-turns, were selected from the evaluation route (see Figure 1) to serve as test subjects. For each selected link, the limits x_{min} , x_{max} and y_{min} , y_{max} were calculated for specific data elements. These limits were defined by the screening conditions for each link (see Section 1), and were calculated in such a way that for each screening condition, one report would violate the lower bound (x_{min}), one would violate the upper bound (x_{max}), and one would satisfy the condition.

As mentioned above, probe and detector data comprise different data elements. To pass the screening, a data element for a given report would have to fall within its respective limits of reasonableness so that $x_{min} < \text{data element} < x_{max}$. For probe reports, these data elements are travel time and congested distance; for detector reports, they are volume and occupancy. Using the same procedure, these data elements are then screened in pairs for consistency (travel time vs. congested distance for probe reports, and volume vs. occupancy for detector reports). In sum, there are 6 screening procedures which can be performed for information from a given link. For example, for (2), representing a 'reasonableness' condition, the limits of travel time for the probe report from link 1 shown Figure 1 were $x_{min} = 35.7$ sec and $x_{max} = 7998.7$ sec (it is clear that the upper limit will hardly ever be reached; it can be adjusted using some educated guessing). Three reports were then generated with travel times of 30, 3000, and 8500 seconds. Of the three generated reports, only one, with a t_p of 3000 seconds, was designed to satisfy this condition.

The data screening algorithm was performed for such simulated data, generating output indicating which data passed and which failed the reasonableness and consistency tests. Results were compared with the test design; that is, whether reports which were generated to pass in fact passed, and whether those generated to fail actually failed.

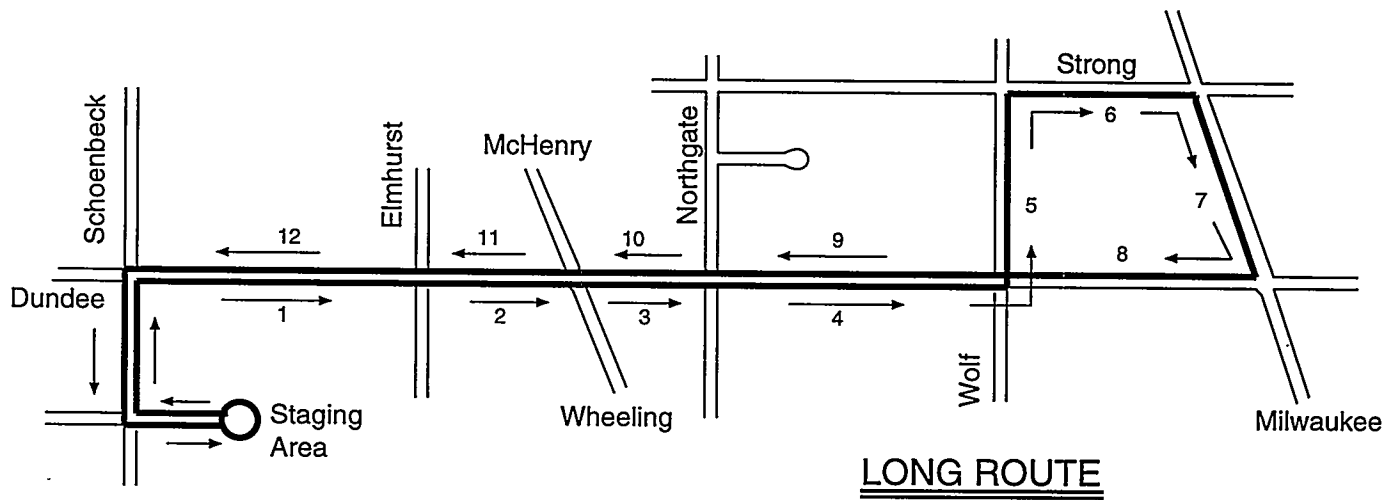

LONG ROUTE

| ADVANCE LINK | ID |
|-----------------|---------|
| 88cb2b - 88cae7 | 1 |
| 88cae7 - 891a48 | 2 |
| 891a48 - 8c689 | 3 short |
| 891a48 - 88cad8 | 3 long |
| 88cad8 - 8c9b3 | 4 |
| 8c9b3 - 88c906 | 5 |
| 88c906 - 88c9a8 | 6 |
| 88c9a8 - 8cad2 | 7 |
| 8cad2 - 8cad8 | 8 |
| 8cad8 - 91a48 | 9 |
| 91a48 - 8cae7 | 10 |
| 8cae7 - 8cb2b | 11 |
| 8cb2b - 8d1f1 | 12 |

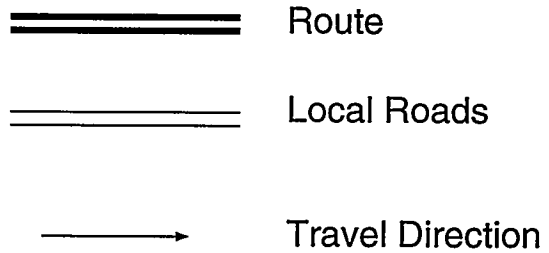

Figure 1: Test Route

2.4 Evaluation Using Actual Data

The critical issue facing evaluation of the actual data is a lack of information as to which reports are in fact correct, and which are not correct. Two limited sources can be utilized for this determination. The first source is the manually recorded measurements performed by observers in the field (using stopwatches), done as part of the Quality of Probe Reports evaluation task. The primary limitation of this source is observer error, the impact of which is unknown. In addition, this source lacks information which could be used to validate the detector reports.

The second source which provides data related to the correctness of the reports is the presence or absence of an incident for a given link during a specified time interval, for both probe and detector data. Because incidents can cause cars to remain motionless for extended periods, we can expect that the presence of an incident may cause some reports to be incorrect. On the other hand, the data recorded during an incident may in fact be correct. While data screening is not designed for use with data generated in the presence of an incident, the lack of available information forces the use of incident data. After the data screening is performed, those reports from the original data sets which have incidents are then compared with those reports which were screened. While not exact, this comparison can act as a tentative benchmark of the correctness of the screening process.

To verify the performance of the data screening algorithm, the actual probe and detector data for selected links were processed off-line by the data screening algorithm. The results from this screening were compared with the incident data derived from the drivers' logs. If there was an incident marked by the driver for some link and some 5-minute time interval, all detector and probe links for this link and this time interval were assigned the same incident flag. [Note: For detector data, only those links with detectors (i.e., links 1, 7, and 11) were used.] This process resulted in each report being assigned to one of the following cases:

1. report failed, incident present,
2. report failed, no incident present,
3. report passed, incident present, and
4. report passed, no incident present.

A report is considered to have failed data screening if any one of the three screening conditions (two reasonableness tests and one consistency test) failed. Otherwise, the report is considered to have passed screening. However, data screening results are considered subject to the limitations of both data sources mentioned above.

2.5 Analysis of Failed Reports

Link reports which failed the reasonableness and/or consistency tests should correspond to either an incident or a probe reporting malfunction. With that premise in mind,

failed reports were analyzed to determine which reports were obviously erroneous, and which should have passed the screening. A comparison of reports which should have passed the screening to those which did in fact fail was then developed.

2.6 Analysis of Passed Reports

As with those reports which failed data screening, reports which passed data screening were checked for possibly erroneous reports, including those reports marked with incidents. As mentioned above, an incident can be an indication of an unusual traffic condition. However, the effect of that incident may be quite unexpected and the corresponding reports themselves may be similar to non-incident reports for congested conditions. Due to a lack of precise criteria to determine incorrect reports, this analysis was somewhat limited.

3 Simulated Data Generation, Processing and Analysis

Links selected for particular tests using the simulated data are presented in the following table. Link numbers used in this table conform to those numbers both on the map and in the table in Figure 1. An 'X' indicates that a report was generated for that particular link to test that particular screening condition. Because some reasonableness and consistency formulae are identical for different categories of links, not all procedures were performed for all links in this step.

| Link | Travel Time Reason. | Congested Distance Reason. | Probe Report Consist. | Volume Reason. | Occupancy Reason. | Detector Report Consist. |
|------|---------------------|----------------------------|-----------------------|----------------|-------------------|--------------------------|
| 4 | X | X | X | | | |
| 6 | X | | X | | | |
| 7 | | | | X | X | X |
| 8 | X | | | | | |

Links in the above table cover the following categories.

1. Link controlled by traffic lights:
 - (a) link 4 - left-turn movement
 - (b) link 8 - through movement
 - (c) link 7 - right-turn movement
2. Link controlled by STOP sign: link 6

A total of twenty-six (26) reports were generated: eighteen (18) probe reports and eight (8) detector reports. These data were then processed by the stand-alone data screening code, a copy of the original code prepared by the EECs group and executed on the TIC computer. The output contains information about the result of each test performed, along with the input data. An example of the output from this code follows:

```

6 19 95   19 45 12   8e3c4   8e4e6   (tt=46.00,cd=0.00)  RTT=1  RCD=1  CProbe=1
6 19 95   19 45 12   92f99   8e60b   (tt=1.98,cd=0.00)  RTT=0  RCD=1  CProbe=0
6 19 95   19 45 12   912ba   a62c1   (tt=43.00,cd=43.00) RTT=1  RCD=1  CProbe=1
6 19 95   19 45 13   88e738   8ee53   (tt=40.00,cd=0.00)  RTT=1  RCD=1  CProbe=1
6 19 95   19 45 13   8cae7   91036   (v=65,o=4)          RVol=1  ROccp=1  CDet=1
6 19 95   19 45 13   88cc8a   9d42f   (v=67,o=3)          RVol=1  ROccp=1  CDet=0
6 19 95   19 45 18   8cb24   8cb20   (v=40,o=2)          RVol=1  ROccp=1  CDet=1
6 19 95   19 45 18   88d079   88cb24   (v=47,o=3)          RVol=1  ROccp=1  CDet=1

```

In the above output, one line represents the screening results for one report. The fields in the output are as follows: 1 and 2 give date and time, respectively; 3 and 4 define the link using hex identifiers; 5 presents actual data reported (tt = travel time, cd = congested distance, v = volume, o = occupancy); and 6-8 show the results of the tests performed for the report, 0 indicating a failed test, 1 a passed test. The abbreviations in fields 6-8 are as follows: RTT is travel time reasonableness, RCD is congested distance reasonableness, CProbe is probe report consistency, RVol is volume reasonableness, ROccp is occupancy reasonableness, and CDet is detector report consistency.

4 Actual Data Generation, Processing, and Analysis

Like the evaluation using simulated data, the evaluation utilizing actual probe data also used links covered by the Test Route as shown in Figure 1. As noted above, in the case of the detector data, only links equipped with a detector were used (links 1, 7, and 11).

For the analysis, the MNA and detector report log files for June 19-22 and Jul 17-20 were retrieved from the Argonne National Laboratory WWW home page, reduced, reformatted appropriately, and processed by the stand-alone Data-Screening module mentioned above. In the case of the detector data, the data aggregated over all detectors within a detector station were used. These data were in the same format as those received on-line by the data screening algorithm. Output data were matched with incident data obtained from the drivers' logs. For each 5-minute interval starting from 12:00 pm, if there was an incident flag for a link, all probe and detector reports for this link and interval were assigned the same incident flag.

5 Results

5.1 Simulated Data

All simulated reports generated as described in Section 2.3 were processed by the data screening algorithm. In other words, testing was done to see whether those reports generated to fail the testing conditions would fail and whether those generated to pass the condition would pass. Because it needed to be determined if the data screening process was working in line with expectations, this first step needed to be concluded before analysis of the actual data could be initiated. Thus, this round of testing acted as the verification of the correctness of the implementation of the data screening algorithm.

5.2 Actual Probe Data

The results of the analysis of the actual probe data are presented in the following table.

| | Passed Screening | Failed Screening | Total |
|--------------|------------------|------------------|-------|
| No incidents | 14704 | 102 | 14806 |
| Incidents | 357 | 8 | 365 |
| Total | 15061 | 110 | 15171 |

The presence of incidents in the above table corresponds to appropriate entries in log files kept by the drivers. The following types of incidents were recorded by the drivers: left-turn blocks traffic, through blocks traffic, train, construction, accident, emergency vehicle, and rain/weather. The large number of incidents in the log files indicates that most incidents were minor.

If there had been no relation between screening and the presence of incidents, but the total number of incidents and data-screening failures had been the same, we would have obtained the following table (values have been rounded to whole numbers to make the interpretation easier).

| | Passed Screening | Failed Screening | Total |
|--------------|------------------|------------------|-------|
| No incidents | 14699 | 107 | 14806 |
| Incidents | 362 | 3 | 365 |
| Total | 15061 | 110 | 15171 |

Assuming the independence of the passage/failure of the individual reports from each other, results were analyzed using a chi-square test. The value of the test statistic is 11.56, which is significant at a 1 per cent level (critical point: 6.64). Therefore, we can reject the null hypothesis that the correlation of passage/failure and the presence of an incident is due to chance. However, the size of the chi-square statistic is essentially due to the fact that data screening trapped 8 incidents correctly, when, if screening were to be totally ineffective, we would have seen a number closer to 2.6.

One accident and seven (7) train blockages constitute the eight (8) reports which failed the screening test and had incidents. Of the 357 reports which passed data screening, 191 reports noted incidents related to accidents and train blockages. The impact of these incidents was clearly not great enough to be flagged by the screening procedure.

The 102 reports where the screening test failed but where no incidents had been found include the following.

1. 26 reports failed the travel time reasonableness test. All of them correspond to travel times over 55 mph, some of them over 100 mph. These reports are apparently due to a probe reporting malfunction.
2. 41 reports failed the reasonableness of congested distance test and indeed correspond to congested distances longer than the link length. Like the previous items, these reports are also most likely due to a probe reporting malfunction.
3. 28 reports failed the consistency test. Due to the high variance of the traffic data, this level of test failure (approx. 0.2%) is considered acceptable even if all of these reports are correct. This acceptance is due to the fact that the data screening algorithm is designed to accept the majority, but not necessarily all, of the correct reports.

5.3 Actual Detector Data

The results of the analysis of the detector data are presented in the following table.

| | Passed Screening | Failed Screening | Total |
|--------------|------------------|------------------|-------|
| No incidents | 1794 | 152 | 1946 |
| Incidents | 7 | 0 | 7 |
| Total | 1801 | 152 | 1953 |

The presence of incidents in this table was as in the log files kept by the drivers. The relatively high percent of failed reports (about 8%) may be due to the random factors in the measurement and the random nature of traffic. This observation suggests that some data screening conditions for detectors may be too restrictive. However, this statement assumes that all non-incident data are expected to be correct, and should not fail screening. As noted above, we lack the criteria needed to validate this assumption.

Using a similar methodology to that in Section 5.2, and assuming that no relationship exists between screening and incidents, the table of expectations would have slightly different values (values have been rounded to whole numbers to make the interpretation easier).

| | Passed Screening | Failed Screening | Total |
|--------------|------------------|------------------|-------|
| No incidents | 1795 | 151 | 1946 |
| Incidents | 6 | 1 | 7 |
| Total | 1801 | 152 | 1953 |

No formal test is needed to show that this table and the previous one have nearly identical values, indicating that no relationship exists between the results of screening and incidents.

6 Conclusions

The first part of the evaluation process using the simulated data indicates that the data screening algorithm is implemented as designed.

The analysis of the results of the data screening for the actual data leads to the following conclusions. As mentioned in Section 5.2, most of the time, when a report failed data-screening and no incident was present, we apparently had a probe reporting malfunction. Also as noted there, some reports which failed data screening had unrealistically high speeds or congested distances larger than the link lengths.

Thus, we reach the conclusion that data screening is rather effective in finding probe reporting malfunctions. This use was itself the purpose of data screening, as prompted by the early-stage technical quality of the MNA's. As such, it did a reasonably good job. While our assessment of the efficacy of the data screening procedure remains somewhat mixed (especially for the detector data), we find the procedure should continue to be used, largely because most of the probe observations which fail the test should indeed be removed from the data base. While it does not do a perfect job, use of the data screening process does improve the data base.

The additional benefit from the evaluation of the data screening algorithm is the verification of the algorithm's implementation (as performed in the stage of the task using simulated data). The error of the implementation revealed by the screening process is described in the Appendix together with suggestions for fine-tuning the algorithm.

References

Berka, S., X. Tian and A. Tarko (1995) Data Fusion Algorithm for ADVANCE Release 2.0, ADVANCE Working Paper Series, No. 48, Urban Transportation Center, University of Illinois, Chicago.

Berka, S. and X. Tian (1995) Changes in Parameters of Data Fusion Subcomponent, Technical Memo, Urban Transportation Center, University of Illinois, Chicago.

Appendix I: Corrections and Suggested Changes

1. According to the design, the volume used in the testing conditions should be a lane volume and not the total approach volume. Division of the volume by number of mid-block lanes from the Attribute Database should be added.
2. The testing criteria for screening detector data consistency could be relaxed.
3. The testing criterion for the maximum probe travel time could be made more restrictive.



APPENDIX C

ADVANCE

Advanced Driver and Vehicle
Advisory Navigation Concept

Traffic Related Functions
Evaluation Report (3 of 7)
Documents # 8460.00

CONTAINS:

| | |
|--|---------------------------------|
| Base Data and Static Profile Evaluation Report | -- Document # 8460-01.01 |
| Data Screening Evaluation Report | -- Document # 8460-02.02 |
| • Quality of Probe Reports Evaluation Report | -- Document # 8460-03.01 |
| Travel Time Prediction and Performance of Probe and Detector Data Evaluation Report | -- Document # 8460-04.01 |
| Detector Travel Time Conversion and Fusion of Probe and Detector Data Evaluation Report | -- Document # 8460-05.01 |
| Frequency of Probe Reports Evaluation Report | -- Document # 8460-06.01 |
| Relationships among Travel Times Evaluation Report | -- Document # 8460-07.02 |

Prepared by
University of Illinois-Chicago
Urban Transportation Center

DISCLAIMER

This report was prepared by a contractor for
Argonne National Laboratory
and is published as it was received.

ADVANCE Evaluation
Quality of Probe Reports

Siim Sööt and Helen Condie

URBAN TRANSPORTATION CENTER
University of Illinois at Chicago
1033 West Van Buren Street
Suite 700 South
Chicago, Illinois 60607

February 1996

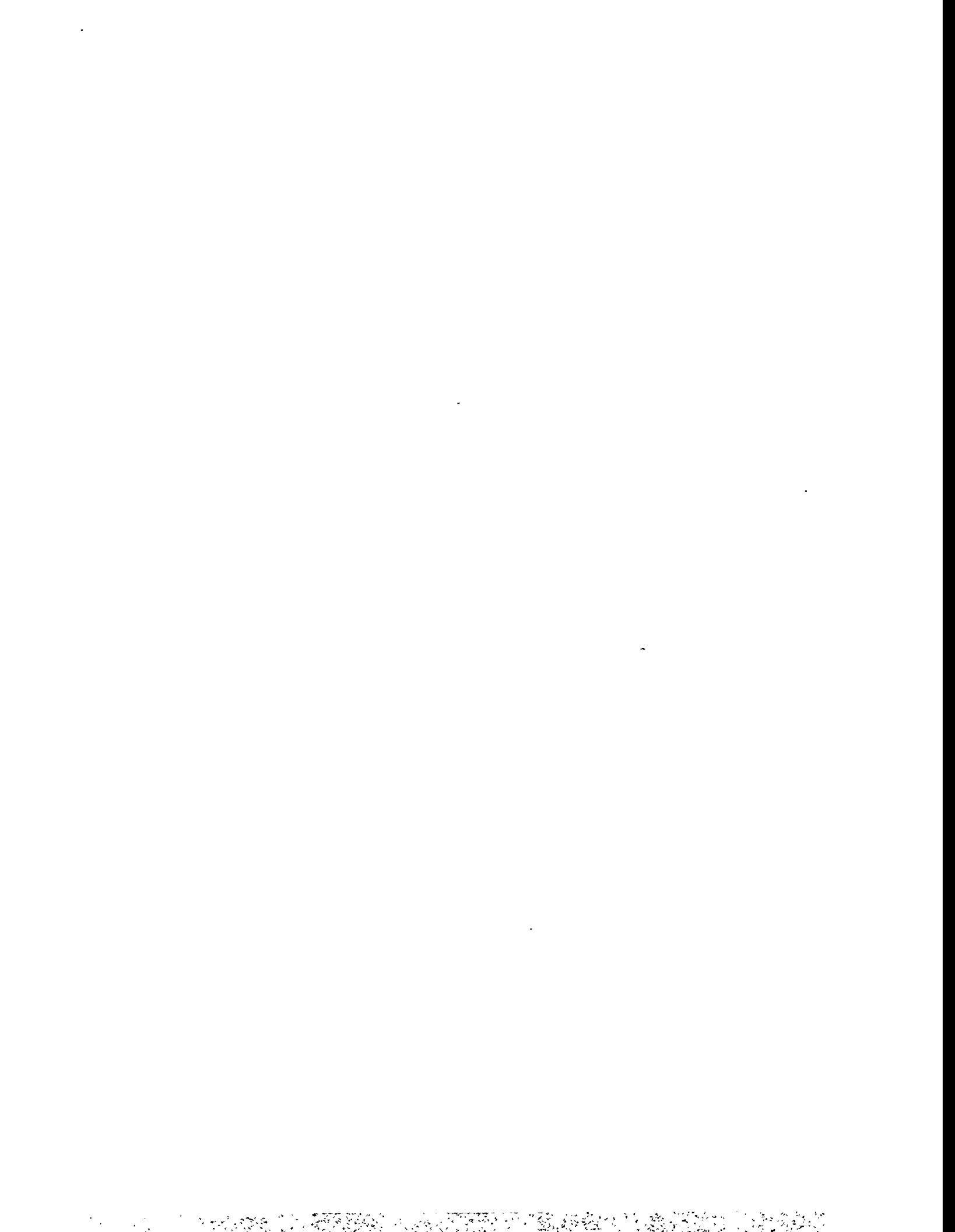

Executive Summary

During the summer of 1995 approximately a dozen vehicles were driven almost 60,000 miles in urban traffic to assess the quality of data generated by probe vehicles. In this process over 55,000 link reports were recorded. These link reports provided information on at least three critical elements of travel: travel time, congested time and congested distance. This information was accumulated in the vehicle's on-board Mobile Navigation Assistant (MNA).

The driving occurred during the early afternoon and the pm peak period and included the hottest part of the day, in a summer which was one of the hottest on record. Many days were over 100°F and the MNA temperatures reached 150°F in some vehicles. Despite these extreme conditions, the equipment performed particularly well.

Two types of quality assessments were performed. The first considered the reasonableness of the data by evaluating speed and two congestion measures. The second assessment compared the probe data to data recorded by human observers. In the first evaluation less than three hundred suspect records (approximately 0.5% of all reports) were found; many could be traced to one faulty MNA. This is a commendable achievement. In the second evaluation, using human observers, the results were also good but not quite as precise. Considering travel time on the link and both congested time and congested distance the conclusion was that the match was sufficiently good between probe and human-observer data that the MNA data are a reliable indicator of traffic conditions.

A substantial amount of data was collected. In these data were some faulty records, but they constituted a very small portion of the total data collected and they were easily detected and deleted. As a whole the probe-vehicle data represent an especially valuable resource for traffic monitoring and analysis.

Contents

| | |
|---|-----------|
| Executive Summary | i |
| 1 Introduction | 1 |
| 1.1 Background | 2 |
| 1.1.1 Driving Schedule | 2 |
| 1.1.2 Unusual Weather Conditions | 4 |
| 1.2 Study Area and Routes | 4 |
| 2 Information Processing in the Probe Vehicle | 8 |
| 2.1 The Vehicle Tracking System | 8 |
| 2.2 The Global Positioning System (GPS) | 9 |
| 2.3 Data Preparation and Formatting | 9 |
| 3 Data Collection and Data Analysis | 10 |
| 3.1 Suspect Speed and Congested-Distance Reports | 10 |
| 3.2 Observer-Recorded Data | 10 |
| 3.2.1 Travel Times | 10 |
| 3.2.2 Congested Distance | 12 |
| 3.2.3 Congested Time | 13 |
| 3.3 Memory-Card Data compared to TIC Data | 13 |
| 4 Suspect Speed and Congested-Distance Reports | 14 |
| 4.1 Suspect Speed Reports | 14 |
| 4.1.1 June and July Sample Data | 14 |
| 4.1.2 All Reports | 16 |
| 4.2 Suspect Congested-Distance Reports | 18 |
| 4.2.1 June and July Sample Data | 19 |
| 4.2.2 All Data | 22 |
| 4.3 Congested-Distance and Congested-Time Comparisons | 24 |
| 4.4 Summary | 24 |
| 5 Observer Comparisons | 26 |
| 5.1 Travel-Time Comparisons | 26 |
| 5.1.1 Observer Travel-Time Comparison by Link | 26 |
| 5.1.2 Observer Travel-Time Comparison by Vehicle | 28 |
| 5.1.3 Observer Travel-Time Comparisons: Turning-Relationships Route | 28 |
| 5.2 Congested-Distance Comparisons | 29 |
| 5.3 Congested-Time Comparisons | 31 |
| 6 Conclusion | 34 |

List of Figures

| | | |
|---|---|----|
| 1 | Probe Data Collection: Long Route | 5 |
| 2 | Probe Data Collection: Short Route | 6 |
| 3 | Probe Data Collection: Turning-Relationships Links | 7 |
| 4 | Link Measurement by Observer and MNA | 12 |
| 5 | Venn Diagram of the Number of Suspect Reports | 25 |
| 6 | Distribution of Travel-Time Differences | 27 |
| 7 | Relationship between Observer and MNA Congested Time (CT) | 33 |

List of Tables

| | | |
|----|---|----|
| 1 | Probe Reports for each day of Data Collection | 3 |
| 2 | Probe Reports for each hour of Data Collection | 4 |
| 3 | MNA Reports by Link | 7 |
| 4 | Quality of Probe Reports, Manual Data Collected | 11 |
| 5 | High Speed June 19-22 | 15 |
| 6 | High Speed July 17-20 | 16 |
| 7 | Reports where Speed exceeds 55mph: by Link | 17 |
| 8 | Reports where Speed exceeds 55mph: by Vehicle | 17 |
| 9 | Multiple Reports over 50mph Speed by a Vehicle in One Day | 18 |
| 10 | Study Route: Link Length | 19 |
| 11 | High Congested Distance (CD 25m over link length): June 19-22 | 20 |
| 12 | High Congested Distance (CD 25m over link length): July 17-20 | 20 |
| 13 | Reports where CD exceeds link length by 10%: by Link** | 22 |
| 14 | Reports where CD exceeds link length by 10%: by Vehicle* | 23 |
| 15 | Number of Reports in which Congested Distance exceeds Link Length | 23 |
| 16 | Congested Distance when Congested Time is Positive | 24 |
| 17 | Distribution of Travel-Time Differences | 27 |
| 18 | Distribution of Travel-Time Differences: Turning-Relationships Route | 29 |
| 19 | Comparison of Observer and MNA Congested Distances | 30 |
| 20 | Comparison of Observer and MNA Congested Times (CT) | 32 |
| 21 | Memory Card v. TIC: Vehicle 17, July 20, 1995 | 36 |
| 22 | Reports for which Congested Distance is more than 10% greater than Link Length | 37 |
| 23 | Distribution of Travel-Time Differences (in seconds): Link 1 | 40 |
| 24 | Distribution of Travel-Time Differences (in seconds): Link 2 | 40 |
| 25 | Distribution of Travel-Time Differences (in seconds): Link 3 | 41 |
| 26 | Distribution of Travel-Time Differences (in seconds): Link 4 | 41 |

| | | |
|----|--|----|
| 27 | Distribution of Travel-Time Differences (in seconds): Link 5 | 42 |
| 28 | Distribution of Travel-Time Differences (in seconds): Link 6 | 42 |
| 29 | Distribution of Travel-Time Differences (in seconds): Link 7 | 43 |
| 30 | Distribution of Travel-Time Differences (in seconds): Link 8 | 43 |
| 31 | Distribution of Travel-Time Differences (in seconds): Link 9 | 44 |
| 32 | Distribution of Travel-Time Differences (in seconds): Link 10 | 44 |
| 33 | Distribution of Travel-Time Differences (in seconds): Link 11 | 45 |
| 34 | Distribution of Travel-Time Differences (in seconds): Link 12 | 45 |
| 35 | Distribution of Travel-Time Differences (in seconds): Vehicle 10 | 46 |
| 36 | Distribution of Travel-Time Differences (in seconds): Vehicle 11 | 46 |
| 37 | Distribution of Travel-Time Differences (in seconds): Vehicle 13 | 47 |
| 38 | Distribution of Travel-Time Differences (in seconds): Vehicle 16 | 47 |
| 39 | Distribution of Travel-Time Differences (in seconds): Vehicle 17 | 48 |
| 40 | Distribution of Travel-Time Differences (in seconds): Vehicle 20 | 48 |
| 41 | Distribution of Travel-Time Differences (in seconds): Vehicle 21 | 49 |
| 42 | Distribution of Travel-Time Differences (in seconds): Vehicle 23 | 49 |
| 43 | Distribution of Travel-Time Differences (in seconds): Vehicle 27 | 50 |
| 44 | Distribution of Travel-Time Differences (in seconds): Vehicle 43 | 50 |
| 45 | Distribution of Travel-Time Differences (in seconds): Vehicle 65 | 51 |
| 46 | Distribution of Travel-Time Differences (in seconds): Vehicle 87 | 51 |

1 Introduction

During the summer of 1995 approximately a dozen vehicles were driven four days a week over an eleven-week period. During this time almost 60,000 miles were driven to produce over 55,000 link reports within a confined study area. These reports provide information on at least three critical elements of travel: travel time, congested time and congested distance. This information is computed in the vehicle (also known as a probe) in its on-board Mobile Navigation Assistant (MNA) and it is recorded in two different ways, directly onto a diskette in the vehicle (the memory card) and by radio frequency to files tabulated at the Traffic Information Center (TIC) in Schaumburg, Illinois.

Data were collected on several study routes from June 5th to August 10th, Monday through Thursday. This data-collection exercise yielded the 50,620 TIC reports examined in this study.

It is the purpose of this report to evaluate the quality of these probe reports (also called MNA reports or link reports) by making several types of comparisons. The Evaluation Test Plan for Quality of Probe Reports called for a test of probe data and observer data for two variables, link travel time and congested distance. We encountered difficulty with observed measurement of congested distance so we expanded the testing to include congested time. Furthermore we also expanded the initial scope of our work by comparing link reports with expected results given link attributes. In summary we performed the following types of comparisons:

- comparing the MNA report data with expected results for three types of data
 - average link speed,
 - congested distance and
 - congested distance and congested time comparisons, and
- comparing the MNA report data with logs kept by human observers for three types of data
 - travel time,
 - congested distance and
 - congested time.

The first comparison is intended to discard any unreasonable data. The second is performed to assess the accuracy of the remaining data. Conclusions regarding these two comparisons cannot be made in a precise manner; guidelines are provided for evaluating the usefulness of the data. It is not the intent of this report to explore the reasons for any faulty reports which may occur.

The overall assessment is that the on-board equipment *performed very well* but given the large amount of information collected there were also, understandably, faulty MNA reports. *Since this study examines mainly these faulty reports the reader may be left with the erroneous impression that the on-board navigation equipment did not function particularly well.* This is not true; based on reasonable expectations of vehicle travel speed and congestion data more than 99% of the reports convey useful data and the approximately half of one percent which appear faulty can be readily deleted by the user. The conclusions based on human observer data are not quite as strong but the utility of the data is again verified.

1.1 Background

The first seven weeks (June 5 to July 20) consisted of driving on set routes centered on Dundee Road in Wheeling, Illinois (north suburban Chicago). Data were collected, with one exception, from Monday to Thursday. Fridays and weekend days were considered, for data collection purposes, to be different day types. The number of reports received on each day of probe data collection is shown in Table 1. This table includes only the data collected on the main Dundee Road study areas (see Section 1.2).

At the end of the Dundee Road data-collection period additional data were collected (August 14 - 18) on a nearby freeway segment (IL-53 / I-290) but the quality of these data could not be evaluated with the techniques used in the Dundee Road study area.

1.1.1 Driving Schedule

At the beginning of each day of data collection, a twelve-noon briefing was held at the ADVANCE office in Schaumburg. At this time the drivers were assigned vehicles and they left the office at approximately 12:30pm. Each driver used a designated route to drive to the study area. There were several different routes; this report is not concerned with the routes to and from the study area. Data were collected by probe vehicles driven in the study area between 1pm and 7pm (Table 2), with breaks as described below.

The driving activity within the quality of probe reports study area generated over 55,000 reports received at the TIC, 50,620 of which are in the primary study area; these are examined in this report. After the memory card system was installed on July 20, 1995 on a typical day there were more memory card reports than reports transmitted to the TIC.

On each day of data collection a field manager was present at the staging area. The field manager ensured that vehicles were driving the study route at satisfactory headways and instructed drivers when to take breaks. The field manager also assisted with MNA failures and other problems which routinely occurred.

The drivers were given a ten-minute break at approximately 2:00pm to 2:10pm and another one from approximately 6:00pm to 6:10pm. Each driver took his or her break

Table 1: Probe Reports for each day of Data Collection

| Date | No of Reports | Percent of Total |
|-------|---------------|------------------|
| 6/05 | 660 | 1.3 |
| 6/07 | 395 | 0.8 |
| 6/08 | 1140 | 2.3 |
| 6/12 | 1382 | 2.7 |
| 6/13 | 1712 | 3.4 |
| 6/14 | 1014 | 2.0 |
| 6/15 | 446 | 0.9 |
| 6/19 | 1178 | 2.3 |
| 6/20 | 1591 | 3.1 |
| 6/21 | 1503 | 3.0 |
| 6/22 | 2372 | 4.7 |
| 6/26 | 2037 | 4.0 |
| 6/27 | 1481 | 2.9 |
| 6/28 | 1744 | 3.4 |
| 6/29 | 1546 | 3.1 |
| 7/05 | 1560 | 3.1 |
| 7/06 | 1996 | 3.9 |
| 7/10 | 1689 | 3.3 |
| 7/11 | 1282 | 2.5 |
| 7/12 | 1507 | 3.0 |
| 7/13 | 1046 | 2.1 |
| 7/17 | 2285 | 4.5 |
| 7/18 | 2252 | 4.4 |
| 7/19 | 2140 | 4.2 |
| 7/20 | 1901 | 3.8 |
| 7/24 | 880 | 1.7 |
| 7/25 | 907 | 1.8 |
| 7/26 | 1017 | 2.0 |
| 7/27 | 899 | 1.8 |
| 7/31 | 949 | 1.9 |
| 8/01 | 1069 | 2.1 |
| 8/02 | 1038 | 2.1 |
| 8/03 | 1139 | 2.3 |
| 8/04 | 949 | 1.9 |
| 8/07 | 1058 | 2.1 |
| 8/08 | 1050 | 2.1 |
| 8/09 | 873 | 1.7 |
| 8/10 | 933 | 1.8 |
| Total | 50,620 | 100.0 |

Table 2: Probe Reports for each hour of Data Collection

| Hour Beginning | No of Reports | Percent of Total |
|----------------|---------------|------------------|
| 1pm | 8464 | 16.7 |
| 2pm | 7980 | 15.8 |
| 3pm | 5187 | 10.2 |
| 4pm | 8488 | 16.8 |
| 5pm | 8433 | 16.7 |
| 6pm | 7871 | 15.5 |
| 7pm | 4197 | 8.3 |
| Total | 50620 | 100.0 |

at a slightly different time, as each was dispatched by the field manager to the break area as they arrived at the staging area. During breaks each probe vehicle was inactive for more than ten minutes as time was lost off-route and also while the vehicle and MNA warmed up. The longest break occurred for 3:30pm to 4:00pm. After this break, during the two-hour peak period from 4:00pm to 6:00pm, the drivers operated their vehicles without scheduled breaks.

1.1.2 Unusual Weather Conditions

The driving took place during the afternoon and early evening. The summer of 1995 was unusually hot and most of the driving was completed during the hottest part of the day. On several days the air temperature exceeded 100°F (38°C) and on the hottest day it peaked at an official 106°F (41°C).

These high temperatures proved to be a serious test for the MNA and without precautions the heat buildup in the trunk of the vehicle (where the MNA was located) caused system failures. The compact-disc unit reached temperatures in excess of 65°C (149°F) in some vehicles. Once the heat problem was recognized, special procedures were devised to alleviate the heat accumulation (opening the trunk to cool the unit during breaks and parking in a shaded area). These procedures substantially reduced MNA failures. Still, there were numerous occasions in which the MNA failed to transmit its activity to the TIC. Some vehicles also had their disk drives replaced, decreasing the MNA failures.

1.2 Study Area and Routes

The entire routes driven on Dundee Road and adjacent arterials were within the municipality of Wheeling, Illinois (north suburban Chicago). Dundee Road was selected because it carries a high volume of traffic and because each signalized intersection is demand actuated by loop detectors (including turning lanes) and there are volume and

occupancy detectors in several locations. Although Dundee Road extends for several miles within the ADVANCE study area the number of potential places along Dundee Road where the necessary field tests could be performed was very limited. The data-collection route required a convenient location where vehicles could turn around safely and avoid being off the study route for a long period of time. The route also needed a mix of link and intersection characteristics.

Two route configurations were used for the field data collection. The first route is the long route and was used for the majority of tests (Figure 1). The long route consists of twelve links. The section of the route on Schoenbeck Road and Palm Drive (near the west end) was used as a staging and turnaround area and since it was too short to complete a recognized link data were not collected for this section of the route. The route was selected to be completed during a fifteen-minute period. This provided the desired frequency of probe reports. Given the size of the driving fleet a longer route would not provide the frequency of reports needed for most tests performed. During the off peak the majority of the drivers completed this twelve-link route in ten to fourteen minutes.

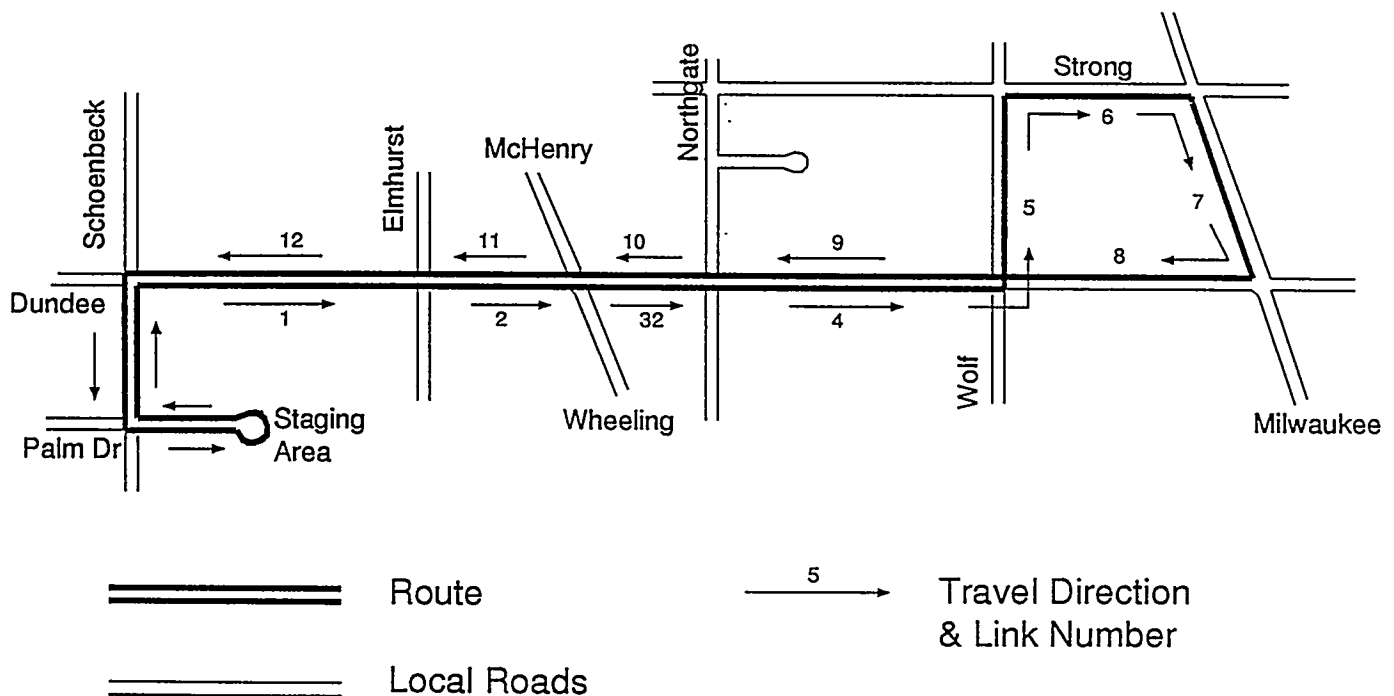

Figure 1: Probe Data Collection: Long Route

During the peak period this route proved to be too long to complete in fifteen minutes and a shorter alternative was used. This is shown in Figure 2. Even the short route could not always be completed in fifteen minutes but this happened infrequently.

Links 4 through 9 are on the long route but do not have the same number of link reports for two reasons (Table 3). First, many of the breaks were taken on this

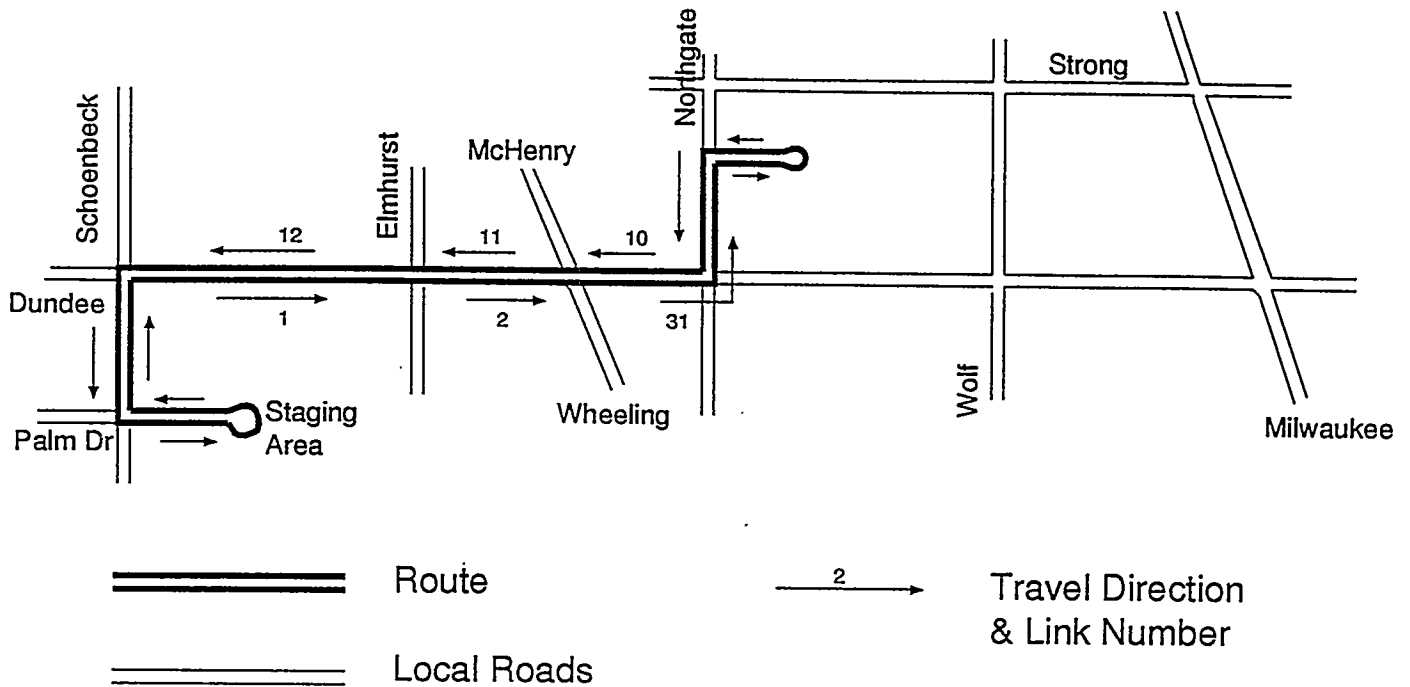

Figure 2: Probe Data Collection: Short Route

portion of the route. The most common break location was on Link 8 and there are correspondingly fewer reports on this link (the vehicles need to travel the entire link without stopping to create a report). Second, there may have been MNA failures and other reasons for turning off the link and stopping.

During the last three weeks in the Dundee Road study area the vehicles were being used to test turning relationships. In this case each driver was given a set of randomly drawn routes, to be driven in sequence, which covered the links shown on Figure 3. This consisted of fourteen uni-directional links. On Link H/h the drivers were permitted to stop and study the rest of the routes they had been assigned to drive. These days generally yielded more than 1500 usable MNA reports, over half of these are on Dundee Road and are used in this study.

Table 3: MNA Reports by Link

| Link | Frequency | Percent | Link | Frequency | Percent |
|-------|-----------|---------|-------|-----------|---------|
| 1 | 5481 | 10.8 | 7 | 2323 | 4.6 |
| 2 | 6298 | 12.4 | 8 | 2172 | 4.3 |
| 3* | 5886 | 11.6 * | 9 | 2462 | 4.9 |
| 4 | 2313 | 4.6 | 10 | 6066 | 12.0 |
| 5 | 2294 | 4.5 | 11 | 7826 | 15.5 |
| 6 | 2293 | 4.5 | 12 | 5206 | 10.3 |
| <hr/> | | | <hr/> | | |
| 31* | 3555 | 7.0 * | | | |
| 32* | 2331 | 4.6 * | | | |
| | | | Total | 50,620 | 100.0 |

* Link 3 consists of two links, 31 and 32. Link 31 is on the short route and includes a left turn at the end of the link. Link 32 is on the long route and has a through movement at the end of the link (no turn).

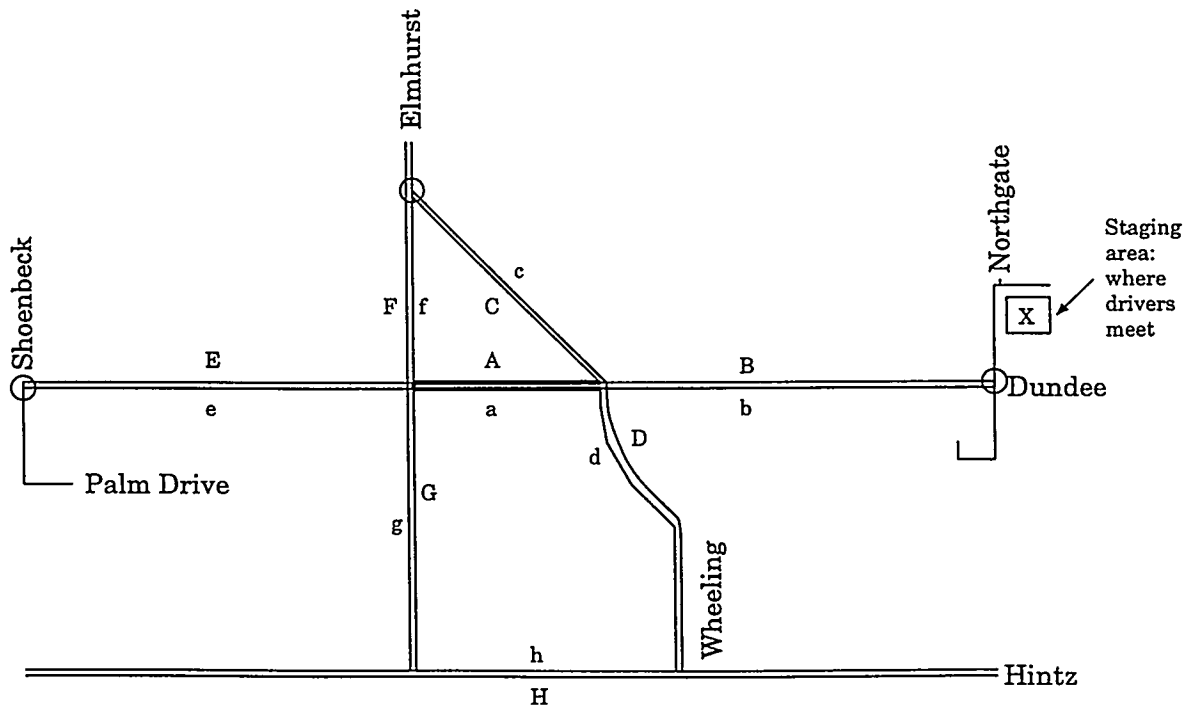

Figure 3: Probe Data Collection: Turning-Relationships Links

2 Information Processing in the Probe Vehicle

Each probe vehicle is equipped with a substantial amount of electronic equipment. This includes a:

- computer,
- compact disc drive,
- radio transmitter and receiver,
- satellite signal receiver,
- RF Antenna,
- GPS Antenna,
- transmission sensor,
- compass/gyroscope,
- display head, and
- cellular telephone.

This equipment allows the probe to estimate its location and therefore to compute critical information, such as travel time, congested time and congested distance, which are examined in this report. The cellular telephone is included for general communication purposes.

The positioning of the vehicle is estimated with two complementary devices:

- the tracking system, and
- the Global Positioning System (GPS).

The tracking system is the principal positioning system and its location estimate is continually contrasted with the location specified by the GPS. When they differ significantly the GPS data are used to determine the probe location.

2.1 The Vehicle Tracking System

The probe vehicle determines its location with a combination of four data items which come from:

- a sensor on the transmission to indicate travel distance,
- a gyroscope in the computer to specify the rate of turning activity,

- a compass to specify direction, and
- map matching to an electronically recorded (compact disc) map data base.

Initially the vehicle position can be manually entered by the driver or obtained automatically from the GPS. With the four pieces of information listed above, and its initial location, the MNA can update its location without the GPS.

2.2 The Global Positioning System (GPS)

Each probe vehicle has a GPS receiver mounted on the exterior of the vehicle somewhere near the rear. This device receives signals from numerous satellites and estimates its position from these signals. Tree cover or other obstructions can interrupt the signals and cause momentary loss of the GPS. The GPS used by the probe vehicles provides a positioning estimate which is accurate to within 100 meters 90% percent of the time.

Since the GPS yields rather crude data the ADVANCE project uses a correcting system known as Differential GPS (DGPS). The error in the regular GPS at any given moment can be assessed by the GPS receiver at the TIC. The precise location of the TIC is known and the error correction is transmitted by radio to the probes. This provides a positioning estimate which is within five meters 50% of the time and within ten meters 95% of the time.

On the MNA monitor, mounted near the dash of the probe, the GPS position is marked by a green circle. When the differential signal is also being received there is a red ring around the green circle. This red ring also signifies that the radio communication with the TIC is active. There are times when the radio link with the TIC is interrupted, e.g., when the MNA is busy and is not servicing the communications port, and since the driver does not actively participate in the operation of the radio it is useful to have a means to indicate the status of the radio connection.

On occasions when the radio link went down for at least a two-minute period the drivers were instructed to stop the vehicle at a safe location and reboot the MNA. During rebooting time and for some period before rebooting no travel information was generated by the vehicle. MNA failure requiring rebooting occurred in several vehicles during a typical day. It is, therefore, often possible to locate a gap in MNA travel data received from a specific vehicle. In full deployment such gaps are not important to the TIC, in that they only lead to a loss of a limited amount of information. In analyzing the data collected in this evaluation it is important to know that involuntary gaps may exist in the data. This would also be useful information for someone tracking a given vehicle.

2.3 Data Preparation and Formatting

The data received by the TIC from probe vehicles on the study routes was stored in decimal and hexadecimal form. The TIC data included reports sent by all ADVANCE

vehicles on all routes traveled. These data were reduced to include only the routes driven in the evaluation study area. The 60,000 miles driven therefore include all the miles accumulated by evaluation probes, but the 50,620 link reports refer only to those links on the study routes used for the quality of probe reports evaluation task.

The reduced data reports from the TIC are in easily readable form and include: date, time, travel time (TT), congested time (CT), congested distance (CD), and vehicle ID. We have added incident type (InT), incident duration (InD) and driver ID numbers to the MNA reports. The memory card data only include the first five variables.

3 Data Collection and Data Analysis

3.1 Suspect Speed and Congested-Distance Reports

One aspect of the evaluation of the quality of probe reports was to compare MNA data with expected results from the probe vehicles. Two types of MNA data, for speed and congested distance, were compared with expected values in this way.

Since the drivers were instructed to drive with the traffic and to stay within the speed limit it is reasonable to expect that speeds recorded by the probe vehicles would not exceed the posted speed limits by more than 10mph to 15mph depending upon the speed limit. In order to identify excessive speeds the MNA data were examined in two phases. First we examined a two-week period in detail and then performed a more broad examination of the entire data-collection period. In the first phase speeds of greater than 50mph and 55mph were used in an effort to distinguish between reasonable speed excesses by the driver and problems with the MNA. In the second phase, data from the whole study period were analyzed to establish if any links or vehicles were responsible for a large number of high-speed reports.

Congested distances recorded by the probe vehicles for each link should not substantially exceed the length of that link. The same two-week sample of data was analyzed and CD reports which exceeded link length were identified. Data from the whole study period were then analyzed to establish if any particular links or vehicles were responsible for a large number of unusually high congested-distance reports.

3.2 Observer-Recorded Data

3.2.1 Travel Times

During the data-collection phase of the MNA evaluation observers rode in the probe vehicles and recorded the exact time at which the probe passed the beginning and end of a link. The data collected is summarized in Table 4.

Each observer was issued a digital watch which was synchronized with the clock in the TIC. The observers were instructed to record the exact time the vehicle passed

Table 4: Quality of Probe Reports, Manual Data Collected

| Date | Observer ID | Car | Veh ID | minutes |
|---------|-------------|-------------|--------|---------|
| June 1 | 15 | Peugeot | 22 | 20 |
| | | Tan Honda | 20 | 179 |
| June 22 | 1 | Merc 320 | 13 | 81 |
| | | Merc 280 | 23 | 59 |
| | | Aerostar | 65 | 31 |
| | | Windstar | 87 | 58 |
| July 6 | 15 | Town Car | 17 | 70 |
| July 10 | 9 | Sable | 43 | 83 |
| July 10 | 4 | Aerostar | 65 | 113 |
| | | Olds 98 | 27 | 132 |
| July 11 | 3 | GMC Jimmy | 10 | 162 |
| | | Windstar | 87 | 100 |
| | | Black Honda | 21 | 132 |
| July 18 | 3 | Bonneville | 11 | 29 |
| | | Peugeot | 22 | 19 |
| | | Merc 280 | 23 | 17 |
| | | Lumina | 16 | 45 |

through the middle of the intersection marking the beginning/end of a link. This is illustrated in Figure 4.

There are two conditions under which the observer time and the MNA time might not match. First, if the vehicle has had to come to a stop and is the first vehicle in the queue behind a traffic signal. Given the accuracy of the vehicle positioning system, it may be possible for the vehicle to record that it had passed through the intersection and therefore was recording time on the next link. Second, and much more likely is the uncertainty the observer has about when the probe has completed the link on a turn. There are at least two turns in the long route (Figure 1), one left and the other right, which may cause this type of uncertainty. On the left turn from Dundee Road to Wolf Road there is a left-turn lane and in cases when the turning vehicle must wait in the middle of the intersection to allow opposing traffic to pass before turning, the probe sits in the middle of the intersection and it may be unclear exactly when one link ends and the next begins. This problem then affects two links (Numbers 4 and 5) in which both recorded travel times are offset by about the same number of seconds, one in the positive direction and the other in the negative direction.

The same situation occurs at the Strong and Milwaukee intersection (Links 6 and 7). On this right turn there is a stop sign and probe vehicles typically need to move slowly forward to have the visibility to ensure that it is safe to proceed. It is not uncommon

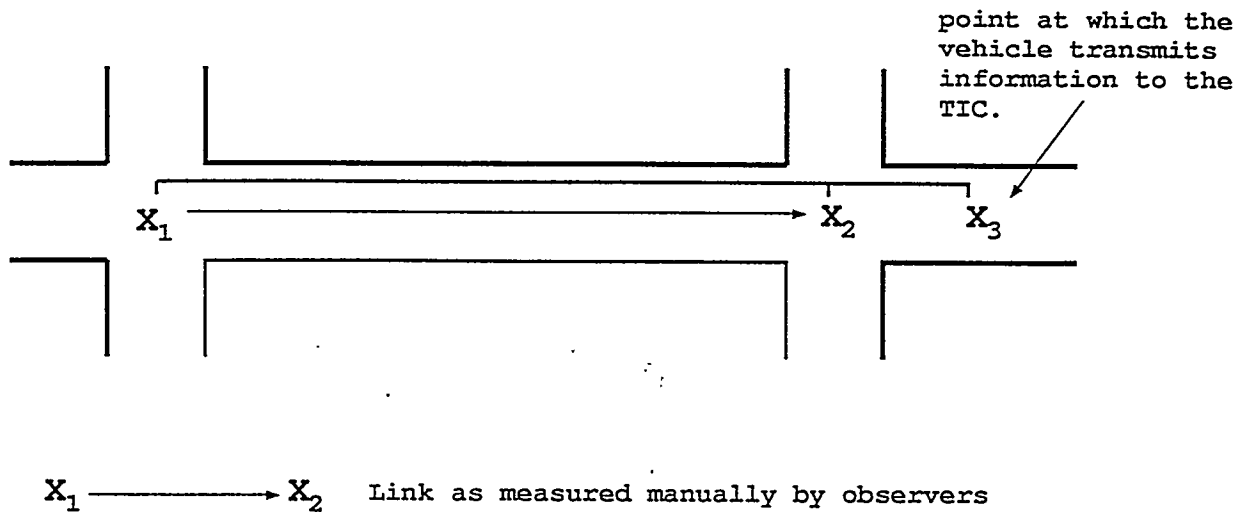

Figure 4: Link Measurement by Observer and MNA

to sit at this intersection, especially during congested periods for 5-10 seconds. Again it is hard to estimate when the vehicle positioning system makes the switch from Link 6 to Link 7.

In addition, it is possible the observers were distracted from the task of noting down travel times, e.g., by talking with the driver of the vehicle. It is not likely that an observer can remain alert for the many hours required to perform this task. This may explain some of the mismatches in MNA versus manually-recorded travel times. A common error made by the observers was to incorrectly write the minute of the recorded time. For example, if the start of the link was at 16:34:50 and the end was 16:34:05 and furthermore the end time of the next link was at 16:35:22 and these two links were of approximately the same length, we know there is a recording problem. In addition to the first travel time being impossible (-45 seconds), the first link is understated by 60 seconds and the next link is overstated by 60 seconds. Since the observers were concentrating on the seconds on the digital watch rather than the minutes, the minute digit was on occasion written incorrectly. These recording errors were easy to identify and they were corrected.

3.2.2 Congested Distance

Congested distance is measured in meters for each link and is the distance traversed by the probe vehicle at a speed of less than 10 meters per second (22.5mph). Congested distance is recorded by the MNA in the probe vehicle and transmitted to the TIC. In the congested-distance field test probe vehicles were driven over a known distance (e.g., between two fixed points or over the entire length of a link) at a speed below 22.5mph, then over a known distance at a speed greater than 22.5mph. In this way

the distance in meters driven at a speed less than 22.5mph is known and should match the congested-distance report from the MNA.

3.2.3 Congested Time

Congested time is measured in seconds and is the time during which the vehicle is stationary or traveling at a speed of less than two meters per second (4.4mph).

To manually record congested time observers rode in the probe vehicles and recorded the exact time during which vehicles were stopped or traveling at speeds below 2 meters per second for each link. Most of the congested time is logged when the vehicle is at a complete stop.

Slow-moving traffic through intersections makes it difficult for the observer to know to which link the congested time needs to be applied. Compounding this difficulty is the coordination which is necessary to ensure that the observer records accurately the time at which the vehicle is moving below speeds of two meters per second (approximately 4.4 miles per hour). Both the beginning and the end of the congested time are subject to this coordination error between the driver and the observer. Two persons are recommended for this task since the driver can announce the moment the vehicle passes the two meters per second mark and the observer can be focused on the watch. This is not an easy evaluation task and, realistically, great precision is not possible.

3.3 Memory-Card Data compared to TIC Data

The ADVANCE system is designed to store driving data on two different media. The link reports are recorded in the probe on memory cards and they are also transmitted by radio to the TIC.

Because of a number of factors not all link reports reach the TIC. There are also some reports which are excluded because they do not yield useful information. U-turns are the best example of this. Since this maneuver is not important to the link travel times (in fact it can potentially be confusing) it is not transmitted to the TIC. Many of these reports are, however, recorded on the memory cards. On this basis alone there should be more memory card reports than TIC reports. However, since the instructions to probe drivers were very precise (for example, not to make U-turns) there should only be a few cases which would result in reports which would not be transmitted to the TIC.

The most elementary comparison is the *number* of reports recorded by the TIC and by the memory card. The July 20, 1995 data for Vehicle 17 were compared. The results of this comparison are given in Table 21 in the Appendix. Regarding the quality of data, the information on the TIC and memory-card reports was identical on all records examined and the discussion in the next section on data quality applies equally to TIC and memory card reports.

4 Suspect Speed and Congested-Distance Reports

Data collected during two weeks, June 19-22 and July 17-20, were analyzed to establish if reports sent from the MNA to the TIC contained unusually high speed or congested-distance data. In addition data collected during the entire data-collection exercise were analyzed to establish if particular links or vehicles were sending high numbers of suspicious speed and congested distance reports. It is again worth emphasizing that the overall quality of data is good but it is useful to explore where faulty reports occurred.

4.1 Suspect Speed Reports

High-speed reports are defined as those reports in which the average speed for the probe vehicle on a link is substantially higher than the speed limit. Probe-vehicle drivers were instructed not to exceed the speed limit but since they were also instructed to drive with the traffic it is possible that speed limits were exceeded and the high speed was not obvious to the driver. On half of the links in the study area the speed limit is 35mph; on Links 1, 9, 11 and 12 the speed limit is 40mph and on Link 6 the speed limit is 25mph. We, therefore, make special note of speeds over both 50mph and 55mph and will determine from the sample June and July data which is the appropriate upper limit.

4.1.1 June and July Sample Data

Table 5 includes the high-speed reports (average link speed greater than 50mph) from data collected during the week of June 19-22. It may be seen from Table 5 that of 6644 MNA reports collected during this week, thirteen reports gave unrealistically high link speeds. Most of these speeds are clearly unrealistic while the last two are unlikely to be accurate readings but not beyond the realm of possibility. All of these thirteen speeds are above 55mph and therefore this does not provide clues about a realistic upper limit.

Five high-speed reports were received from Vehicle 65 and two high-speed reports were received from Vehicle 14. The high frequency of Vehicle 65 suggests a problem with this unit.

There is also a pattern with links. Links 9 and 10 together account for approximately half of all the high-speed reports recorded during this week in June.

None of these high-speed reports show incidents recorded by the driver. The most common incidents, such as cycle failure ($InT = 1$) and train crossings ($InT = 4$), occur on some links but it is logical that they would not be found in these high-speed circumstances. In the system of coding incidents the other values were 2 and 3 for turning and through movement blocking traffic, 5 for construction, 6 and 7 for MNA problems, 8 for being off the designated route and 9 for weather related traffic problems, e.g., heavy rain.

Seventeen high-speed reports, with speeds over 50mph, were found in the 8578

Table 5: High Speed June 19-22

| Date | Time | TT | CD | CT | Link | Vehicle | InT | InD | Speed(mph) |
|---------|----------|----|----|----|------|---------|-----|-----|------------|
| 6 19 95 | 18 19 21 | 6 | 0 | 0 | 10 | 14 | 0 | 0 | 150 |
| 6 20 95 | 16 25 41 | 13 | 0 | 0 | 2 | 27 | 0 | 0 | 78 |
| 6 20 95 | 17 52 3 | 10 | 42 | 0 | 10 | 65 | 0 | 0 | 90 |
| 6 20 95 | 18 51 11 | 12 | 0 | 2 | 11 | 65 | 0 | 0 | 85 |
| 6 20 95 | 19 5 18 | 23 | 38 | 0 | 12 | 65 | 0 | 0 | 80 |
| 6 21 95 | 16 54 37 | 4 | 19 | 0 | 9 | 9 | 0 | 0 | 479 |
| 6 21 95 | 17 30 58 | 6 | 50 | 0 | 9 | 21 | 0 | 0 | 319 |
| 6 22 95 | 14 31 38 | 3 | 24 | 0 | 32 | 65 | 0 | 0 | 300 |
| 6 22 95 | 17 14 19 | 12 | 41 | 0 | 10 | 16 | 0 | 0 | 75 |
| 6 22 95 | 18 29 0 | 8 | 12 | 0 | 31 | 21 | 0 | 0 | 112 |
| 6 22 95 | 18 38 0 | 4 | 19 | 0 | 9 | 13 | 0 | 0 | 479 |
| 6 22 95 | 18 39 8 | 27 | 52 | 17 | 12 | 65 | 0 | 0 | 68 |
| 6 22 95 | 19 18 26 | 18 | 0 | 0 | 2 | 14 | 0 | 0 | 57 |

MNA reports collected during the week of July 17-20 (Table 6). Five of these reports are between 50mph and 55mph and they all occur during the off-peak. Moreover they are all less than 52mph and since they report no congested distance and no congested time they appear to legitimately portray free-flow conditions and as such should not be deleted. They likewise show no incidents.

Two of the seventeen high-speed reports, on the other hand, give average link speeds of 59.0mph. These do not appear to be an accurate reflection of the conditions. The first 59.0 mph report, on July 17, is for Link 8, a part of Dundee Road with alot of frontage access and considerable traffic. The second report, on July 18, shows a cycle failure lasting 179 seconds. This clearly is inconsistent with the thirty-one second travel time on this link. These two tables, then, suggest that 50mph is too strict and a 55mph is a more reasonable limit for discarding reports on the basis of speed.

Four high-speed reports were received from Vehicle 9 and two high-speed reports were received from Vehicles 13, 27 and 43. It appears that the problems of Vehicle 65, found in the June data, have been corrected but Vehicle 9 now has a problem. As a whole, the magnitude of the errors in July is considerably smaller that the June errors.

Five of the high-speed reports were recorded on Link 8 and three on Link 9; only one high-speed report during this week in July comes from Link 10 (cf. the June data). Consequently, the evidence here suggests that the relationship between links and problem reports needs further study, as pursued in the next section.

Table 6: High Speed July 17-20

| Date | Time | TT | CD | CT | Link | Vehicle | InT | InD | Speed(mph) |
|---------|----------|----|----|----|------|---------|-----|-----|------------|
| 7 17 95 | 14 42 02 | 18 | 0 | 0 | 32 | 23 | 0 | 0 | 50.1 |
| 7 17 95 | 17 25 56 | 20 | 0 | 0 | 1 | 9 | 0 | 0 | 91.4 |
| 7 17 95 | 18 15 10 | 20 | 0 | 0 | 2 | 87 | 0 | 0 | 51.1 |
| 7 17 95 | 18 31 09 | 25 | 20 | 0 | 8 | 20 | 0 | 0 | 59.0 |
| 7 17 95 | 18 40 09 | 37 | 0 | 0 | 9 | 43 | 0 | 0 | 51.8 |
| 7 17 95 | 19 02 09 | 20 | 0 | 0 | 2 | 87 | 0 | 0 | 51.1 |
| 7 18 95 | 14 59 18 | 28 | 0 | 0 | 9 | 9 | 0 | 0 | 68.4 |
| 7 18 95 | 18 27 57 | 18 | 0 | 0 | 32 | 13 | 0 | 0 | 50.1 |
| 7 18 95 | 18 16 03 | 20 | 0 | 0 | 8 | 13 | 0 | 0 | 73.8 |
| 7 18 95 | 18 31 53 | 20 | 0 | 0 | 8 | 17 | 0 | 0 | 73.8 |
| 7 18 95 | 18 51 37 | 14 | 65 | 0 | 5 | 22 | 0 | 0 | 81.5 |
| 7 18 95 | 19 02 39 | 31 | 90 | 4 | 1 | 27 | 1 | 179 | 59.0 |
| 7 19 95 | 13 28 30 | 8 | 0 | 0 | 8 | 27 | 0 | 0 | 184.5 |
| 7 19 95 | 14 33 13 | 20 | 0 | 0 | 9 | 43 | 6 | 180 | 95.8 |
| 7 19 95 | 15 54 32 | 25 | 4 | 21 | 4 | 9 | 0 | 0 | 76.7 |
| 7 19 95 | 18 30 55 | 14 | 20 | 0 | 10 | 9 | 0 | 0 | 64.4 |
| 7 20 95 | 18 6 36 | 6 | 37 | 0 | 8 | 14 | 1 | 60 | 246.1 |

4.1.2 All Reports

Data collected during the ten-week data-collection exercise were analyzed to establish if probes on particular links sent large numbers of high-speed reports. The number of high-speed reports (when average link speed is greater than 55mph as suggested in the previous section) for each link on the study route is shown in Table 7. These reports account for less than 0.2% of all probe reports, or less than two per thousand.

More than one quarter of the 87 high-speed reports (25 reports) were on Link 10; Links 8 and 9 each account for over 10% of the total high-speed reports. Link 10 is a moderately short link which passes over a rail crossing; it has only one access near the west end from a shopping complex.

The number of high-speed reports (when average link speed is greater than 55mph) for each vehicle used in the ten-week data collection exercise is shown in Table 8. Vehicle 65 (25 reports) accounts for over one quarter of the 87 high-speed reports; Vehicle 43 (11 reports) accounts for over one fifth of the high-speed reports. None of the other vehicles sent more than 7% of the total number of high-speed reports. This suggests a problem with two MNAs.

It is appropriate at this point to consider whether drivers contributed to these reports. It should be noted that no driver was assigned the same vehicle more than once a week and in most cases several weeks passed before an individual drove the same

Table 7: Reports where Speed exceeds 55mph: by Link

| Link | Frequency | Percent | | Link | Frequency | Percent |
|------|-----------|---------|--|-------|-----------|---------|
| 1 | 8 | 9.1 | | 7 | 1 | 1.1 |
| 2 | 8 | 9.1 | | 8 | 13 | 14.8 |
| 31 * | 2 | 2.3 | | 9 | 14 | 15.9 |
| 32 * | 7 | 8.0 | | 10 | 25 | 28.4 |
| 4 | 3 | 3.4 | | 11 | 2 | 2.1 |
| 5 | 1 | 1.1 | | 12 | 3 | 3.4 |
| 6 | 0 | 0 | | | | |
| | | | | Total | 87 | 100 |

* 31 - short route (left turn) * 32 - long route (no turn)

Table 8: Reports where Speed exceeds 55mph: by Vehicle

| Vehicle | Frequency | Percent | | Vehicle | Frequency | Percent |
|---------|-----------|---------|--|---------|-----------|---------|
| 9 | 6 | 6.9 | | 23 | 2 | 2.3 |
| 10 | 4 | 4.6 | | 25 | 1 | 1.1 |
| 11 | 2 | 2.3 | | 27 | 5 | 5.7 |
| 13 | 2 | 2.3 | | 43 | 11 | 12.6 |
| 14 | 3 | 3.4 | | 62 | 3 | 3.4 |
| 16 | 4 | 4.6 | | 65 | 25 | 28.7 |
| 17 | 1 | 1.1 | | 69 | 2 | 2.3 |
| 19 | 1 | 1.1 | | 87 | 2 | 2.3 |
| 20 | 3 | 3.4 | | 89 | 2 | 2.3 |
| 21 | 3 | 3.4 | | 92 | 2 | 2.3 |
| 22 | 3 | 3.4 | | | | |
| | | | | Total | 87 | 100 |

vehicle again. A random assignment was attempted but because the vehicle fleet and pool of drivers changed daily, this was not implemented as initially designed. However, an effort was made to cycle drivers through all of the vehicles.

All days with multiple high-speed reports were examined. Table 9 shows that while Vehicles 65 and 43 are responsible for a large proportion of the high-speed reports, these high-speed reports appear to be associated with the vehicles and not with drivers. Here 50mph is used rather than 55mph to broaden the scope in determining the role of drivers.

Table 9: Multiple Reports over 50mph Speed by a Vehicle in One Day

| Date | Vehicle ID | Driver ID | Number of Reports |
|---------|------------|-----------|-------------------|
| Aug 1 | 19 | 4 | 2 |
| June 12 | 43 | 7 | 4 |
| June 13 | 43 | 17 | 7 |
| June 27 | 43 | 2 | 3 |
| June 29 | 43 | 4 | 2 |
| June 20 | 65 | 21 | 3 |
| June 22 | 65 | 3 | 2 |
| June 26 | 65 | 6 | 13 |
| June 27 | 65 | 12 | 2 |
| July 11 | 65 | 9 | 2 |
| July 12 | 65 | 13 | 2 |
| July 17 | 87 | 11 | 2 |
| July 31 | 92 | 7 | 2 |

Note: All other vehicles produced no more than one 50+ mph report per day.

4.2 Suspect Congested-Distance Reports

High congested-distance reports are those reports where the congested-distance exceeds the link length. The link lengths for each of the twelve links on the study route are given in Table 10.

Initially the sample two-week data in June and July include those reports where the recorded congested-distance exceeds the link length by more than twenty-five meters. Since the error can be attributed to each of two link ends the error can be considerably more than twenty-five meters, but this is a good starting point. With a measurement from an odometer we cannot anticipate great precision. Accordingly, in the analysis which uses all data collected during the study period the high congested-distance reports presented are those where the recorded congested-distance exceeds the link length by at least 10%. We can assume that reports which exceed the link length by less than

10% are valid reports, conveying highly congested circumstances, but when the excess is more than 10% then we believe it is no longer appropriate to keep this probe report in the data set. Note also that the length of the link may not be accurately recorded in the roadway attribute data base and some tolerance should be allowed for this possibility.

Table 10: Study Route: Link Length

| Link | Length (m) | Link | Length (m) |
|------|------------|------|------------|
| 1 | 817 | 7 | 520 |
| 2 | 457 | 8 | 660 |
| 3 | 403 | 9 | 856 |
| 4 | 857 | 10 | 403 |
| 5 | 510 | 11 | 457 |
| 6 | 482 | 12 | 817 |

4.2.1 June and July Sample Data

Table 11 includes the high congested-distance reports from the data collected during the week of June 19-22. During this week, of the 6644 MNA reports collected, eight contained high congested-distance reports. Two high congested-distance reports were received from Vehicle 65 and two high congested-distance reports were received from Vehicle 16. Although none of the high CD data of Table 11 matches the high-speed data of Table 5, the recurrence of Vehicle 65 suggests a problem with this MNA.

Considering the frequency of links, it appears that Links 3 and 10 continue to occur disproportionately. They represent the same road segment but travel is in opposite directions. Perhaps the shortness of the link is playing a role here. Note also that three of the four cases in Table 11 which have differences of less than 10% of the link length are during the 4pm to 6pm peak period. These reports may be accurately conveying congested conditions and should not be discarded. The other four reports (with especially large differences) occur during the off-peak and are less likely to be conveying highly congested conditions. Table 11, then, provides evidence for increasing the threshold for high congested distance from 25 meters to 10% of the link length. To the extent that distance is measured by an odometer, a distance based criterion such as link length makes sense.

During the week of July 17-20, of a total number of 8578 MNA reports collected, 49 contained high congested-distance reports (Table 12). Ten high congested-distance reports were received from Vehicle 20 and five high congested-distance reports were received from Vehicles 17 and 27. Four high congested-distance reports were received from Vehicles 9, 13, 22 and 23. Four links, 7, 8, 9 and 10 account for all except one of the

Table 11: High Congested Distance (CD 25m over link length): June 19-22

| Date | Time | TT | CD | CT | Link | | Vehicle | InT | InD | Difference | |
|---------|----------|-----|------|-----|------|--------|---------|-----|-----|------------|------|
| | | | | | ID | Length | ID | | | (m) | % |
| 6 19 95 | 15 46 26 | 399 | 485 | 341 | 31 | 403 | 16 | 0 | 0 | 82 | 20.3 |
| 6 19 95 | 17 54 38 | 91 | 431 | 28 | 10 | 403 | 65 | 0 | 0 | 28 | 6.9 |
| 6 20 95 | 15 22 57 | 108 | 430 | 7 | 10 | 403 | 23 | 0 | 0 | 27 | 6.7 |
| 6 20 95 | 16 30 20 | 93 | 502 | 1 | 31 | 403 | 13 | 0 | 0 | 99 | 24.6 |
| 6 20 95 | 17 45 55 | 375 | 905 | 216 | 9 | 856 | 17 | 0 | 0 | 49 | 5.7 |
| 6 20 95 | 17 58 30 | 261 | 554 | 200 | 7 | 520 | 87 | 0 | 0 | 34 | 6.5 |
| 6 21 95 | 18 56 30 | 227 | 510 | 145 | 31 | 403 | 16 | 0 | 0 | 107 | 26.6 |
| 6 22 95 | 14 3 13 | 594 | 2968 | 1 | 8 | 660 | 65 | 0 | 0 | 2308 | 350 |

Note: Difference = Congested Distance less the Link Length

high congested-distance reports recorded during this week in July. Twenty-four high congested-distance reports were recorded on Link 7; eleven high congested-distance reports were recorded on Link 10; eight high congested-distance reports were recorded on link 9; five high congested-distance reports were recorded on Link 8.

Twenty-six of the high congested-distance reports were coded for incident 1 - cycle failure, while the other twenty-three were without recorded incident codes. The three reports with greatest differences, all over 200 meters, lack an incident code, implying that these are faulty reports. Beyond this there are no other obvious patterns in the high CD reports but it is likely, given the high proportion of cycle failures recorded, that many of these reports accurately convey congested conditions and a flexible standard such as 10% above the link length should be used.

Table 12: High Congested Distance (CD 25m over link length): July 17-20

| Date | Time | TT | CD | CT | Link | | Vehicle | InT | InD | Difference | |
|---------|----------|-----|-----|-----|------|--------|---------|-----|-----|------------|------|
| | | | | | ID | Length | ID | | | (m) | % |
| 7 17 95 | 17 4 20 | 271 | 588 | 135 | 7 | 520 | 13 | 1 | 180 | 68 | 13.1 |
| 7 17 95 | 17 11 12 | 316 | 958 | 112 | 9 | 856 | 17 | 0 | 0 | 102 | 11.9 |
| 7 17 95 | 17 27 6 | 316 | 623 | 236 | 7 | 520 | 20 | 0 | 0 | 103 | 19.8 |
| 7 17 95 | 18 0 49 | 122 | 448 | 4 | 10 | 403 | 19 | 0 | 0 | 45 | 11.2 |
| 7 18 95 | 15 2 10 | 110 | 489 | 4 | 10 | 403 | 13 | 0 | 0 | 86 | 21.3 |
| 7 18 95 | 16 1 58 | 343 | 556 | 244 | 7 | 520 | 20 | 1 | 130 | 36 | 6.9 |
| 7 18 95 | 16 30 41 | 339 | 551 | 264 | 7 | 520 | 16 | 1 | 180 | 31 | 6.0 |
| 7 18 95 | 16 30 41 | 341 | 764 | 170 | 7 | 520 | 22 | 1 | 360 | 244 | 46.9 |

| Date | Time | TT | CD | CT | Link | | Vehicle | | InT | InD | Difference | |
|---------|----------|-----|------|-----|------|--------|---------|---|-----|-----|------------|---|
| | | | | | ID | Length | ID | | | | (m) | % |
| 7 18 95 | 16 48 39 | 321 | 651 | 246 | 7 | 520 | 20 | 1 | 205 | 131 | 25.2 | |
| 7 18 95 | 16 55 20 | 288 | 887 | 149 | 9 | 856 | 20 | 1 | 155 | 31 | 3.6 | |
| 7 18 95 | 16 55 35 | 112 | 553 | 14 | 10 | 403 | 13 | 1 | 60 | 150 | 37.2 | |
| 7 18 95 | 17 15 54 | 314 | 586 | 220 | 7 | 520 | 20 | 1 | 170 | 66 | 12.7 | |
| 7 18 95 | 17 16 1 | 309 | 594 | 236 | 7 | 520 | 23 | 1 | 300 | 74 | 14.2 | |
| 7 18 95 | 17 40 47 | 331 | 610 | 210 | 7 | 520 | 21 | 1 | 250 | 90 | 17.3 | |
| 7 18 95 | 17 43 3 | 294 | 626 | 183 | 7 | 520 | 20 | 1 | 130 | 106 | 20.4 | |
| 7 18 95 | 17 47 5 | 402 | 579 | 337 | 7 | 520 | 22 | 1 | 360 | 59 | 11.3 | |
| 7 18 95 | 17 47 18 | 200 | 909 | 81 | 9 | 856 | 23 | 0 | 0 | 53 | 6.2 | |
| 7 18 95 | 17 49 35 | 137 | 488 | 44 | 10 | 403 | 23 | 0 | 0 | 85 | 21.1 | |
| 7 18 95 | 17 56 3 | 260 | 644 | 92 | 7 | 520 | 17 | 0 | 0 | 124 | 23.8 | |
| 7 18 95 | 18 2 45 | 258 | 675 | 128 | 7 | 520 | 20 | 1 | 100 | 155 | 29.8 | |
| 7 19 95 | 14 11 44 | 189 | 556 | 126 | 7 | 520 | 20 | 0 | 0 | 36 | 6.9 | |
| 7 19 95 | 15 11 49 | 109 | 607 | 1 | 10 | 403 | 9 | 0 | 0 | 204 | 50.6 | |
| 7 19 95 | 16 24 6 | 107 | 521 | 8 | 10 | 403 | 17 | 0 | 0 | 118 | 29.3 | |
| 7 19 95 | 17 15 30 | 290 | 812 | 130 | 7 | 520 | 9 | 0 | 0 | 292 | 56.2 | |
| 7 19 95 | 17 20 0 | 306 | 971 | 148 | 9 | 856 | 43 | 1 | 180 | 115 | 13.4 | |
| 7 19 95 | 17 29 1 | 447 | 649 | 373 | 7 | 520 | 27 | 1 | 240 | 129 | 24.8 | |
| 7 19 95 | 17 29 22 | 348 | 578 | 262 | 7 | 520 | 11 | 1 | 420 | 58 | 11.2 | |
| 7 19 95 | 17 36 9 | 349 | 844 | 127 | 7 | 520 | 22 | 0 | 0 | 324 | 62.3 | |
| 7 19 95 | 17 45 10 | 349 | 911 | 228 | 9 | 856 | 22 | 1 | 300 | 55 | 6.4 | |
| 7 19 95 | 17 51 4 | 397 | 575 | 310 | 7 | 520 | 13 | 1 | 65 | 55 | 10.6 | |
| 7 19 95 | 17 54 4 | 115 | 443 | 35 | 10 | 403 | 43 | 0 | 0 | 40 | 9.9 | |
| 7 19 95 | 18 5 15 | 420 | 658 | 341 | 7 | 520 | 65 | 1 | 375 | 138 | 26.5 | |
| 7 19 95 | 18 16 23 | 329 | 600 | 190 | 7 | 520 | 17 | 1 | 105 | 80 | 15.4 | |
| 7 20 95 | 15 9 7 | 92 | 501 | 2 | 10 | 403 | 14 | 0 | 0 | 98 | 24.3 | |
| 7 20 95 | 16 22 11 | 343 | 920 | 220 | 9 | 856 | 27 | 0 | 0 | 64 | 7.5 | |
| 7 20 95 | 16 43 50 | 255 | 698 | 154 | 8 | 660 | 9 | 1 | 230 | 38 | 5.8 | |
| 7 20 95 | 17 7 21 | 275 | 584 | 164 | 2 | 457 | 20 | 0 | 0 | 127 | 27.8 | |
| 7 20 95 | 17 9 20 | 93 | 440 | 43 | 10 | 403 | 17 | 0 | 0 | 37 | 9.2 | |
| 7 20 95 | 17 10 27 | 624 | 807 | 537 | 8 | 660 | 43 | 1 | 106 | 147 | 22.3 | |
| 7 20 95 | 17 12 29 | 622 | 689 | 531 | 8 | 660 | 27 | 0 | 0 | 29 | 4.4 | |
| 7 20 95 | 17 15 51 | 327 | 1015 | 201 | 9 | 856 | 43 | 1 | 52 | 159 | 18.6 | |
| 7 20 95 | 17 18 9 | 459 | 610 | 372 | 7 | 520 | 14 | 1 | 240 | 90 | 17.3 | |
| 7 20 95 | 17 34 55 | 329 | 732 | 244 | 8 | 660 | 16 | 1 | 312 | 72 | 10.9 | |
| 7 20 95 | 17 45 33 | 300 | 788 | 175 | 8 | 660 | 27 | 0 | 0 | 128 | 19.4 | |
| 7 20 95 | 17 51 49 | 114 | 462 | 68 | 10 | 403 | 87 | 0 | 0 | 59 | 14.6 | |
| 7 20 95 | 18 4 3 | 323 | 910 | 200 | 9 | 856 | 9 | 1 | 315 | 54 | 6.3 | |
| 7 20 95 | 18 7 56 | 94 | 437 | 3 | 10 | 403 | 104 | 0 | 0 | 34 | 8.4 | |
| 7 20 95 | 18 30 5 | 341 | 649 | 263 | 7 | 520 | 27 | 0 | 0 | 129 | 24.8 | |
| 7 20 95 | 18 38 52 | 386 | 652 | 323 | 7 | 520 | 20 | 0 | 0 | 132 | 25.4 | |

Note: Difference = Congested Distance less the Link Length

4.2.2 All Data

As a result of the factors discussed above, in the analysis of the complete data set only those reports that exceed the link length by at least 10% were examined. Table 13 lists these high-CD reports for each link in the study area; together they account for less than 0.2% of all probe reports.

As the most congested link in the evaluation study area, Link 7 accounts for almost 40% of all high congested-distance reports. Link 10 accounts for another 30% of all high congested-distance reports recorded. The only other link where a significant number of such reports were recorded is Link 31, the 'same' section of road as Link 10 but in the opposite direction.

Table 13: Reports where CD exceeds link length by 10%: by Link**

| Link | Frequency | Percent | | Link | Frequency | Percent |
|------|-----------|---------|--|-------|-----------|---------|
| 1 | 0 | 0 | | 7 | 37 | 38.9 |
| 2 | 3 | 3.3 | | 8 | 4 | 4.2 |
| 31 * | 12 | 12.6 | | 9 | 2 | 2.1 |
| 32 * | 2 | 2.1 | | 10 | 30 | 31.6 |
| 4 | 0 | 0 | | 11 | 5 | 5.3 |
| 5 | 0 | 0 | | 12 | 0 | 0 |
| 6 | 0 | 0 | | | | |
| | | | | Total | 95 | 100 |

* 31 - short route (left turn) * 32 - long route (no turn)

**Total link reports examined: 50,620

The number of high congested-distance reports (when congested distance reported for a link exceeds link length by more than 10%) for each vehicle used in the ten-week data-collection exercise is shown in Table 14. Vehicle 17 and Vehicle 10 each account for over 10% of all high congested-distance reports recorded during the entire study period; Vehicle 43 accounts for nearly 10% of all high congested-distance reports.

The number of reports when the congested distance recorded for a link is greater than link length, when it exceeds link length by 5% and when it exceeds link length by 10% is given in Table 15. This table indicates that even if a more stringent criterion of CD 5% greater than link length is used, the number of high-CD reports increases by only 36.

Table 22 in the Appendix lists all 95 high-CD reports, when congested-distance exceeds link length by more than 10%.

Table 14: Reports where CD exceeds link length by 10%: by Vehicle*

| Vehicle | Frequency | Percent | | Vehicle | Frequency | Percent |
|---------|-----------|---------|--|---------|-----------|---------|
| 9 | 4 | 4.2 | | 22 | 7 | 7.4 |
| 10 | 3 | 3.2 | | 23 | 3 | 3.2 |
| 11 | 2 | 2.1 | | 27 | 6 | 6.3 |
| 13 | 7 | 7.4 | | 40 | 1 | 1.1 |
| 14 | 2 | 2.1 | | 43 | 9 | 9.5 |
| 16 | 5 | 5.3 | | 65 | 6 | 6.3 |
| 17 | 13 | 13.7 | | 66 | 2 | 2.1 |
| 19 | 1 | 1.1 | | 80 | 1 | 1.1 |
| 20 | 10 | 10.5 | | 87 | 4 | 4.2 |
| 21 | 6 | 6.3 | | 92 | 3 | 3.2 |
| | | | | Total | 95 | 100.0 |

* Total link reports examined: 50,620

Table 15: Number of Reports in which Congested Distance exceeds Link Length

| Ratio of CD to Link Length | Number of Reports |
|----------------------------|-------------------|
| 1.001 - 1.05 | 51 |
| 1.051 - 1.10 | 36 |
| over 1.10 | 95 |
| Total | 182 |

4.3 Congested-Distance and Congested-Time Comparisons

There are also logical inconsistencies in the data which need to be considered. One is the relationship between congested distance and congested time. It is not likely that a vehicle which records a positive CT, having traveled under 5 mph or has stopped, has not recorded a positive CD, i.e., CD should be greater than zero. Of the 50,620 reports transmitted to the TIC from our study routes during the entire study period, there were 43 reports where a positive value is recorded for congested time and a value of zero is recorded for congested distance (Table 16). All but one of these 43 reports was recorded by Vehicle 65. We considered AASHTO specifications and other alternatives and could not determine with accuracy the minimum distance traveled by a vehicle accelerating and decelerating between 22.5 mph and 5 mph. Table 16 provides us with clues. Up to a CD value of approximately 21-25 meters, Vehicle 65 accounts for most of the records. This suggests a faulty MNA. Over 25 meters the reports are distributed among a large number of vehicles. This suggests approximately 115 faulty reports on this criterion, from the first six rows in Table 16. These 115 reports account for only 0.2% of all the probe reports.

Table 16: Congested Distance when Congested Time is Positive

| CD (m) | Total Number of Reports | —Number of Reports— | | | | |
|---------|-------------------------|---------------------|--------|--------|--------|--------|
| | | Veh 65 | Veh 13 | Veh 21 | Veh 11 | Veh 43 |
| 0 | 43 | 42 | 0 | 0 | 0 | 0 |
| 1 - 5 | 9 | 8 | 0 | 0 | 0 | 0 |
| 6 - 10 | 11 | 10 | 0 | 1 | 0 | 0 |
| 11 - 15 | 11 | 9 | 1 | 0 | 0 | 0 |
| 16 - 20 | 11 | 4 | 1 | 1 | 0 | 0 |
| 21 - 25 | 30 | 6 | 2 | 1 | 2 | 3 |
| 26 - 30 | 82 | 9 | 5 | 8 | 6 | 6 |
| 31 - 35 | 166 | 17 | 8 | 13 | 11 | 15 |

4.4 Summary

Three criteria were applied to detect faulty reports. Each identified approximately one hundred reports which appear incorrect. Some of these reports, however, were identified more than once. If the MNA malfunctioned it is reasonable to expect that it may affect more than one item in the report. Figure 5 illustrates the degree of overlap in the flagged data. It shows that there is only one common area, between high speeds and CT/CD mismatch. The eleven reports here indicate that the vehicle was traveling over 55mph and that it also recorded congested time but did not have a sufficient congested distance to permit decelerating from 22.5mph to 4.4mph and again resuming a speed over 22.5mph. Other than this overlap the suspected faulty reports appear to be independent of each other.

Figure 5:

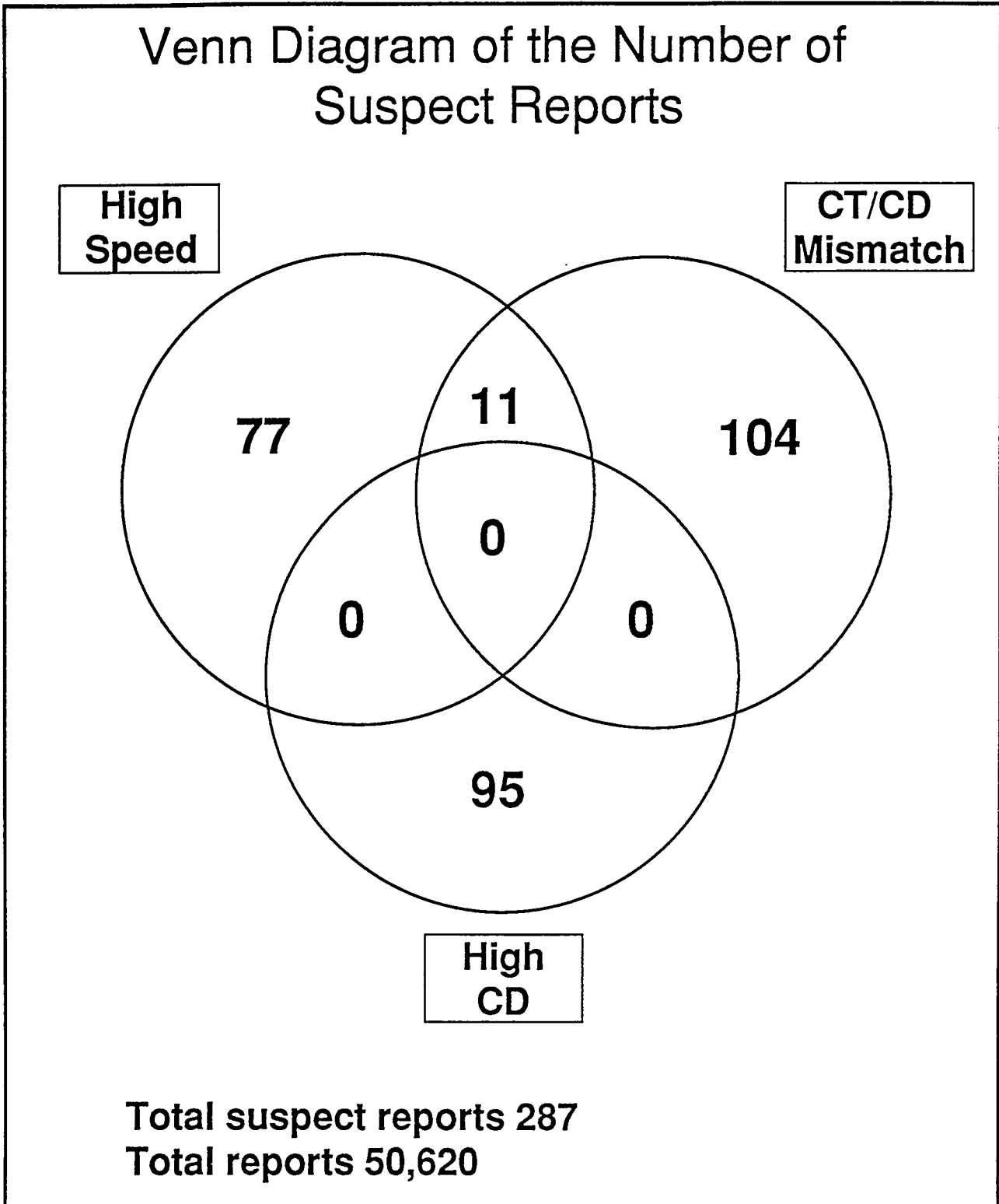

5 Observer Comparisons

In the previous section the focus was on suggesting guidelines for discarding faulty records. In this section the emphasis is on assessing the comparability of probe and human-observer data. This is, however, not an exact science. When there is a difference between the probe and observer data much of it must be attributed to measurement error so there must be a reasonable range of acceptable differences. Also, when major differences occur it is not frequently possible to ascertain which is correct. This comparison is, nevertheless, an important phase of the evaluation process and it further supports the utility of the probe data.

5.1 Travel-Time Comparisons

The travel times manually recorded by observers traveling as passengers in the probe vehicles were compared with MNA travel-time reports. In order to do this the manually-recorded travel times were added to the reduced MNA data files; the resulting data files were then analyzed.

The analysis showed that average difference in travel times (MNA minus observer travel times) is 0.4 seconds with a standard deviation of 5.5 seconds ($n = 776$). Approximately seven of every eight differences (87.6%) were within ± 5 seconds and 94% were within ± 10 seconds. Distribution of the difference between the MNA recorded travel times and the observer-recorded travel times is shown in Figure 6 and the 87.6% of the reports with differences less than five seconds are shown in Table 17. These indicate there is a good fit between observer and MNA travel-time reports.

5.1.1 Observer Travel-Time Comparison by Link

The distribution of the difference between the MNA-recorded travel times and the manually-recorded travel times for each of the twelve links is shown in Tables 23 to 34 in the Appendix (the manually-recorded travel time data collected is summarized in Table 4). These tables show that over 85% of the manually-recorded travel times were within ± 5 seconds of the travel times recorded by the MNA for all but two of the study route links – Link 7 and Link 8. It is possible that the right turn on red may have caused some uncertainty about when the vehicle reached the end of Link 7 and began Link 8. Such uncertainty could have substantially affected both links.

Considering the average difference between the probe and observer travel times by link, four links have values greater than or equal to 1.0 second. These are Link 2 (-1.0 seconds), Link 7 (2.4 seconds), Link 10 (1.3 seconds) and Link 12 (1.5 seconds). It is understandable that Link 7, with the highest travel times, due more to congestion than length, also has the greatest average difference.

Table 17: Distribution of Travel-Time Differences

| | Difference | No. of Reports | % of Total Reports |
|-------|------------|----------------|--------------------|
| | -5 | 20 | 2.6 |
| | -4 | 26 | 3.4 |
| | -3 | 39 | 5.0 |
| | -2 | 73 | 9.4 |
| | -1 | 105 | 13.5 |
| | 0 | 101 | 13.0 |
| | +1 | 102 | 13.1 |
| | +2 | 80 | 10.3 |
| | +3 | 73 | 9.4 |
| | +4 | 40 | 5.2 |
| | +5 | 21 | 2.7 |
| Total | | | 87.6 |

Note: Difference = MNA travel time less observer-recorded travel time (in seconds)

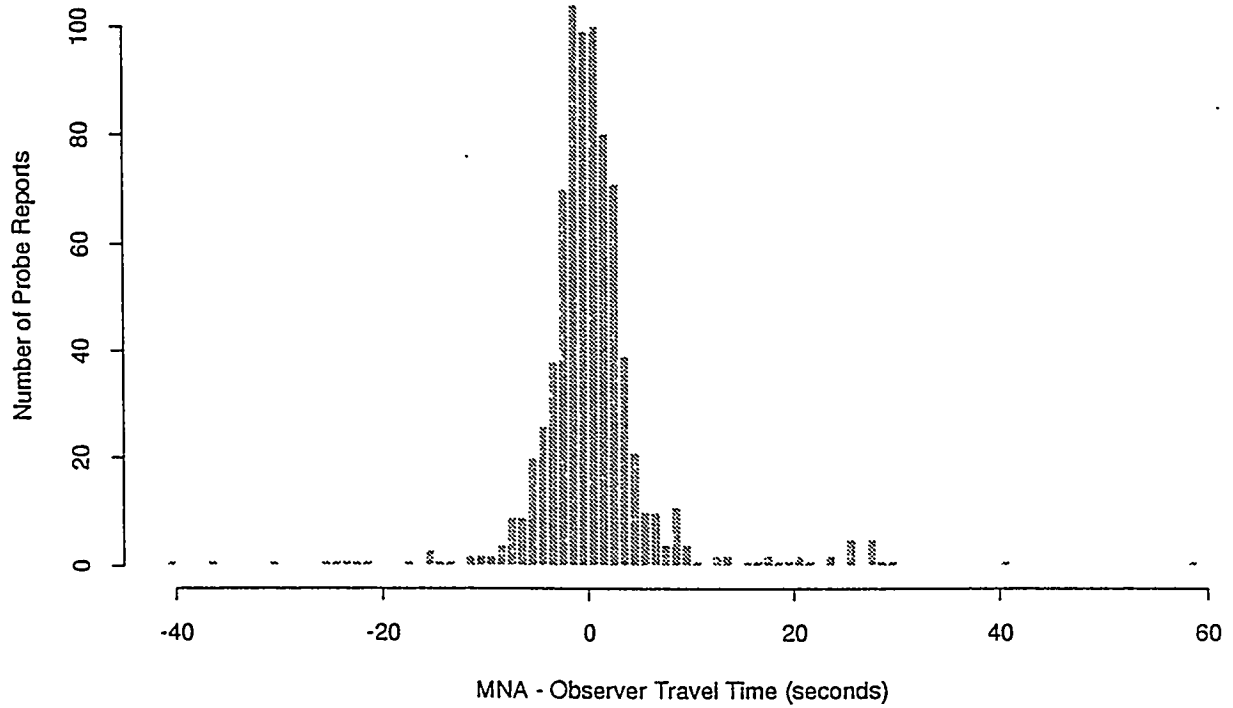

Figure 6: Distribution of Travel-Time Differences

5.1.2 Observer Travel-Time Comparison by Vehicle

The distribution of the difference between the MNA-recorded travel times and the manually-recorded travel times for each of the twelve probe vehicles used in the data-collection exercise is shown in Tables 35 to 46 in the Appendix (the manually-recorded travel time data collected is summarized in Table 4). These tables show that over 85% of the manually-recorded travel times were within +/- 5 seconds of the travel times recorded by the MNA for all but three of the vehicles used in quality of probe reports data collection; Vehicles 11, 21 and 87. For Vehicle 11 62.7% of the manually-recorded travel times were within +/- 5 seconds of the MNA-recorded travel time. For Vehicle 21 67.5% of the manually-recorded travel times were within +/- 5 seconds of the MNA-recorded travel time. For Vehicle 87, 77.3% of the manually-recorded travel times were within +/- 5 seconds of the MNA-recorded travel time.

The same observer - observer number 3 - is responsible for all manually-recorded travel times in Vehicles 11 and 21, and for over half of all the manually-recorded travel times in Vehicle 87 (100 minutes out of 158 minutes of manual data collection - see Table 4). It therefore appears likely that we have a problem with a bad observer rather than a problem with the MNA in these vehicles. This further supports the conclusion that the MNAs are functioning well.

This conclusion is reinforced by examining the average differences between probe and observer travel times by vehicle and contrasting it to the examination above of differences by link. Of the twelve vehicles tested, Vehicle 23 had the greatest average difference of 1.4 seconds and Vehicle 11 was next with 1.3 seconds. These differences are smaller than the differences found above-by link, where the highest value was 2.4 seconds. It appears that the MNA is working well; the link differences are greater than the vehicle differences. Moreover, it appears that probe data are more consistently correct than human observations. Humans may be distracted more often than machines are faulty.

5.1.3 Observer Travel-Time Comparisons: Turning-Relationships Route

On one day during data collection on the turning relationships route (Figure 3), manual observations of travel times were made. One observer traveled as a passenger in several different vehicles. The link travel times noted by this observer were compared with MNA travel-time reports.

The analysis showed that only 75% of the manually-recorded travel times were within +/- 5 seconds of the travel times recorded by the MNA. The distribution of the differences between the MNA-recorded travel times and the manually-recorded travel times for the observations made on the turning relationships route is given in Table 18. These data were not combined with the earlier analysis because there were an unusually large number of turns and these turns contribute to differences between MNA and observer travel-time data.

The same observer - observer number 25 - was responsible for all manually-recorded travel-time data on the turning-relationships route. Because the task was made more difficult by the high number of turns, we expected and found the percentage of reports within five seconds to be lower. We are satisfied with the result.

Table 18: Distribution of Travel-Time Differences: Turning-Relationships Route

| | Difference | No. of Reports | % of Total Reports |
|-------|------------|----------------|--------------------|
| | -5 | 1 | 1.1 |
| | -4 | 3 | 3.4 |
| | -3 | 1 | 1.1 |
| | -2 | 4 | 4.5 |
| | -1 | 9 | 10.2 |
| | 0 | 10 | 11.4 |
| | +1 | 14 | 15.9 |
| | +2 | 12 | 13.6 |
| | +3 | 7 | 8.0 |
| | +4 | 4 | 4.5 |
| | +5 | 1 | 1.1 |
| Total | | | 74.8 |

Difference = MNA travel time less observer-recorded travel time (in seconds).

5.2 Congested-Distance Comparisons

Congested distance is the distance the vehicle travels at speeds of less than ten meters per second (36 kilometers per hour or 22.5 miles per hour). In order to validate the MNA congested distance (CD) the vehicle needs to move at below this speed between known markers for which the distance is known or can be easily be measured. It was exceptionally difficult to perform this driving activity to any level of precision. The first two sets of records (June 1 and August 24) on Table 19 were derived by changing speeds several times above and below ten meters per second. Not surprisingly the observer and MNA data do not match particularly well. The differences can be easily attributed to both the distance computation system in the vehicle and the difficulty in making the vehicle perform at required speeds between the exact markers on the link.

It was much easier to evaluate the performance of the MNA by driving the entire link at speeds under ten meters per second. This is reported on Table 19 for the September 29 and October 13 dates. While these congested distances are unrealistically long for normal driving conditions, they deviate up to 25 meters from the link length (observed

Table 19: Comparison of Observer and MNA Congested Distances

| Date | Vehicle ID | Observer Distance | MNA Distance |
|---------|------------|-------------------|--------------|
| June 1 | 16 | 315 | 296 |
| June 1 | 16 | 315 | 339 |
| June 1 | 16 | 315 | 290 |
| June 1 | 16 | 210 | 228 |
| Aug 24 | 19 | 245 | 285 |
| Aug 24 | 19 | 245 | 228 |
| Aug 24 | 19 | 245 | 267 |
| Aug 24 | 19 | 245 | 247 |
| Aug 24 | 19 | 245 | 228 |
| Aug 24 | 19 | 245 | 155 |
| Aug 24 | 19 | 245 | 256 |
| Aug 24 | 19 | 245 | 266 |
| Aug 24 | 19 | 245 | 206 |
| Aug 24 | 19 | 245 | 213 |
| Aug 24 | 19 | 245 | 237 |
| Aug 24 | 19 | 245 | 256 |
| Aug 24 | 19 | 245 | 230 |
| Aug 24 | 19 | 245 | 228 |
| Sept 29 | 84 | 280 | 249 |
| Sept 29 | 84 | 280 | 298 |
| Sept 29 | 84 | 280 | 307 |
| Sept 29 | 84 | 280 | 281 |
| Oct 13 | 22 | 690 | 705 |
| Oct 13 | 22 | 690 | 686 |
| Oct 13 | 22 | 690 | 689 |
| Oct 13 | 22 | 690 | 661 |
| Oct 13 | 22 | 690 | 681 |
| Oct 13 | 22 | 690 | 718 |
| Oct 13 | 22 | 535 | 512 |
| Oct 13 | 22 | 535 | 568 |
| Oct 13 | 22 | 535 | 570 |
| Oct 13 | 22 | 535 | 548 |
| Oct 13 | 22 | 535 | 533 |
| Oct 13 | 22 | 535 | 551 |
| Oct 13 | 22 | 225 | 245 |
| Oct 13 | 22 | 225 | 238 |
| Oct 13 | 22 | 225 | 209 |
| Oct 13 | 22 | 225 | 245 |
| Oct 13 | 22 | 225 | 243 |
| Oct 13 | 22 | 225 | 217 |

distance). This suggests that this measurement has more variability than the travel time and that measuring short CDs would likely be characterized by large percentage differences between observer and MNA data.

It was also easy to simulate the $CD=0$ condition. In this case the vehicle traverses the link without slowing to less than ten meters per second. This is not at all an unusual condition having occurred for 16.7% of the links during the summer driving period (9455 of the 50,620 reports examined). In the several dozens of times in which we performed the 'CD=0 test' the MNA detected no CD. We were satisfied that the MNA performed very well in measuring congested distance.

5.3 Congested-Time Comparisons

Congested time, the duration the vehicle travels at speeds less than 2 meters per second, is much easier to assess because this is very close to being immobile. In most instances the bulk of the CT is logged while the vehicle is at a complete stop. CT is equal to zero in 35.7% of the links examined ($n=20,243$) and it is less than ten seconds in a total of 27,991 links or in nearly half of the link reports examined.

There was generally close correspondence between observer logs and MNA congested time data. Given the imprecision of noting the exact time the vehicle drops below the critical speed it is almost remarkable that the observer and MNA data are so close. The log and MNA congested distance reports for one vehicle (Vehicle 84) can be seen in Table 20 and for all the data collected on Figure 7.

One of the vehicles accounts for three outliers on Figure 7. Since these represent the greatest difference between observer and MNA data the general assessment here is that the MNA reports the CT very well. This is especially the case since there is no good means to determine whether the three outliers can be attributed to the MNA or the observer.

Table 20: Comparison of Observer and MNA Congested Times (CT)

| Date | Vehicle | MNA CT | Observed CT |
|--------|---------|--------|-------------|
| Sep 29 | 84 | 4 | 4 |
| Sep 29 | 84 | 50 | 52 |
| Sep 29 | 84 | 20 | 14 |
| Sep 29 | 84 | 15 | 10 |
| Sep 29 | 84 | 14 | 14 |
| Sep 29 | 84 | 53 | 56 |
| Sep 29 | 84 | 106 | 109 |
| Sep 29 | 84 | 0 | 2 |
| Sep 29 | 84 | 12 | 14 |
| Sep 29 | 84 | 0 | 2 |
| Sep 29 | 84 | 61 | 58 |
| Sep 29 | 84 | 8 | 6 |
| Sep 29 | 84 | 0 | 2 |
| Sep 29 | 84 | 16 | 17 |
| Sep 29 | 84 | 4 | 5 |
| Sep 29 | 84 | 0 | 2 |

Congested travel times is the time (in seconds) the vehicle speed is less than two meters per second

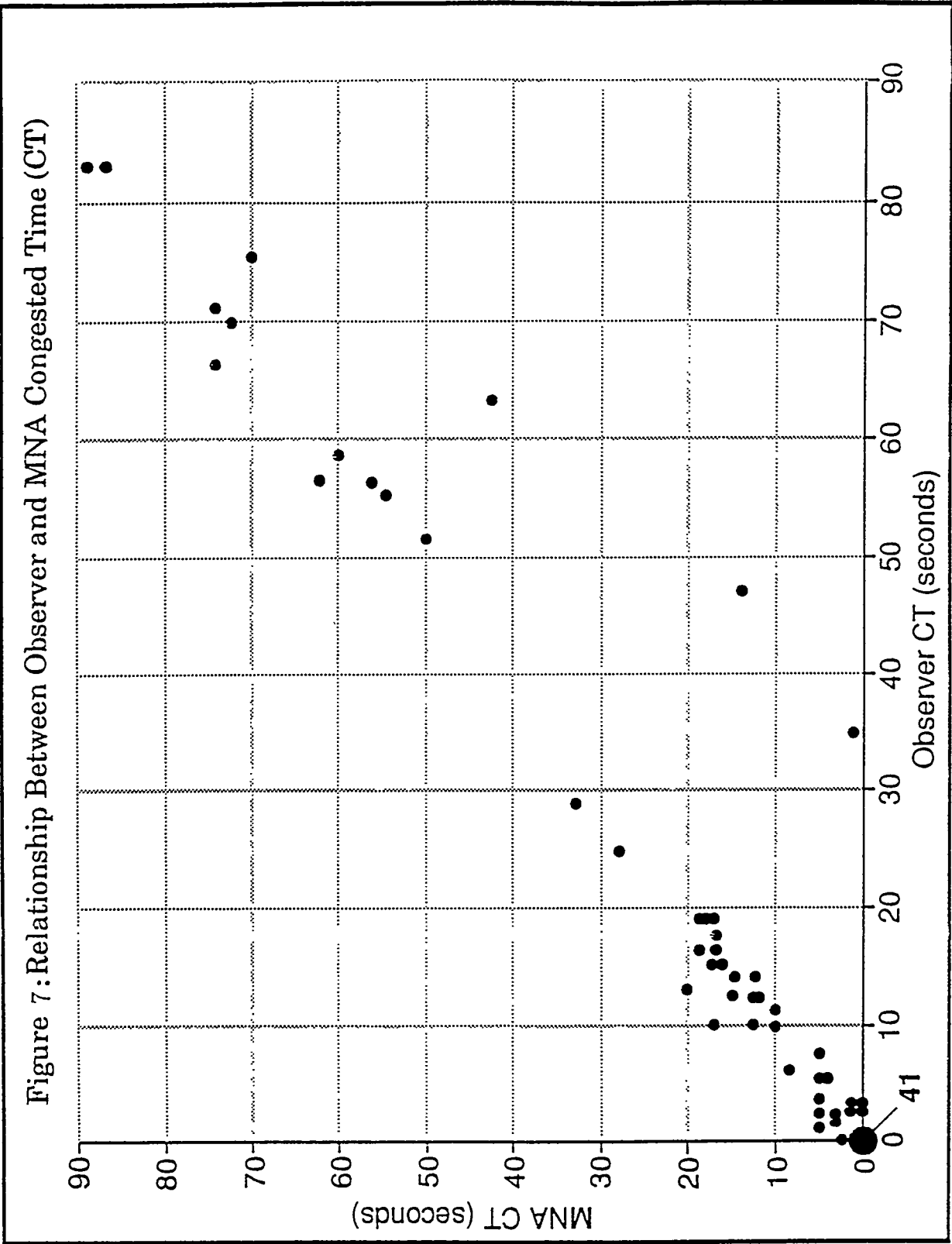

6 Conclusion

This study examined 50,620 link reports collected during an eleven-week period in the summer of 1995. The driving occurred during the hottest part of the day, the afternoon and early evening, in a summer which was one of the hottest on record. Indeed, the 106°F temperature recorded on one of the data-collection days was the hottest official temperature recorded in Chicago. Many other days were over 100°F and the MNA temperatures reached 150°F in some vehicles. Despite these extreme conditions, the equipment performed well.

Two types of quality assessments were performed. The first considered the reasonableness of the data by evaluating speed and two congestion measures. The second assessment compared the probe data to data recorded by human observers. This latter test requires human judgement and the use of measuring devices and it therefore cannot be considered to be an exact measurement. It is, however, an important evaluation step as it provides useful information.

The first evaluation was performed on all 50,620 reports and found the data to be exceptionally good. If 1% of the reports are determined to be faulty then with the number of records examined this would sum to 506 records. None of the suspicious speed, CT and CD conditions imposed here uncovered more than 125 problem records. Together they account for less than three hundred records or only approximately one half of one percent. This is a commendable achievement.

Currently the data files include all data collected. Nothing has been deleted. If a simple screen is imposed then the problem records can be discarded and the data can be used in this reduced form. For someone interested in all the recorded information it is intact. Some of these faulty records likely do not provide much useful information. If an MNA report exceeded the speed limit by a substantial margin then even if this accurately reflects probe activity it would probably happen during the off-peak when cruise-time conditions are anticipated and would not contribute much information. Other reports on high CDs or illogical matches between CT and CD may be reflecting highly congested conditions and the deletion of these reports would be more problematic. In a case in which the CD value is too high but there is severe congestion, discarding this record would actually eliminate potentially useful information.

We recommend that users make their own decisions about which reports to delete. This study suggests the following. Delete reports if the speeds exceed 55mph, the CD exceeds link length by 10% and the CD is less than 25 meters when the CT is positive.

In the second evaluation phase, using human observers, the results were also good but not quite as conclusive as in the first phase. Considering travel time on the link and both congested time and congested distance the conclusion is that the match is sufficiently good between probe and human-observer data that the MNA data are a reliable indicator of travel conditions.

In sum, a substantial amount of data was collected during the summer months. In these data are some faulty records. The faulty records constitute a very small

proportion of the total data collected and they can be easily detected and deleted. As a whole the probe-vehicle data represent an especially valuable resource for traffic analysis and we anticipate considerable interest in these data.

Appendix

Memory Card Data compared to TIC Data

During the core period, from 2:00 pm to 7:00 pm, Vehicle 17 recorded 115 TIC link reports and 119 memory card reports (Table 21). More importantly during the key 4:00 pm to 6:00 pm peak period (16:00 to 17:59) there was a difference of only one report. There appeared to be no apparent reason, based on the route of the vehicle, for the missing TIC reports. The small sample size would not permit generalizations about reasons for missing reports. The difference in the number of reports is small at less than 5%.

Table 21: Memory Card v. TIC: Vehicle 17, July 20, 1995

| Time | TIC Reports | Memory Card Reports |
|-------------|-------------|---------------------|
| 13:00-13:59 | 22 | 22 |
| 14:00-14:59 | 34 | 34 |
| 15:00-15:59 | 16 | 17 |
| 16:00-16:59 | 30 | 31 |
| 17:00-17:59 | 18 | 18 |
| 18:00-18:59 | 17 | 19 |
| 19:00-19:59 | 13 | 13 |

Table 22: Reports for which Congested Distance is more than 10% greater than Link Length

| No | TT | CD | CT | Link ID | Link Length | Vehicle | InT | InD | Ratio |
|----|-----|-----|-----|---------|-------------|---------|-----|-----|---------|
| 1 | 170 | 507 | 119 | 2 | 457 | 92 | 0 | 0 | 1.10941 |
| 2 | 127 | 537 | 30 | 2 | 457 | 21 | 0 | 0 | 1.17505 |
| 3 | 275 | 584 | 164 | 2 | 457 | 20 | 0 | 0 | 1.27790 |
| 4 | 407 | 573 | 333 | 7 | 520 | 43 | 1 | 240 | 1.10192 |
| 5 | 277 | 575 | 207 | 7 | 520 | 20 | 0 | 0 | 1.10577 |
| 6 | 397 | 575 | 310 | 7 | 520 | 13 | 1 | 65 | 1.10577 |
| 7 | 348 | 578 | 262 | 7 | 520 | 11 | 1 | 420 | 1.11154 |
| 8 | 402 | 579 | 337 | 7 | 520 | 22 | 1 | 360 | 1.11346 |
| 9 | 314 | 586 | 220 | 7 | 520 | 20 | 1 | 170 | 1.12692 |
| 10 | 271 | 588 | 135 | 7 | 520 | 13 | 1 | 180 | 1.13077 |
| 11 | 388 | 589 | 309 | 7 | 520 | 43 | 0 | 0 | 1.13269 |
| 12 | 340 | 591 | 220 | 7 | 520 | 21 | 1 | 420 | 1.13654 |
| 13 | 309 | 594 | 236 | 7 | 520 | 23 | 1 | 300 | 1.14231 |
| 14 | 263 | 600 | 191 | 7 | 520 | 21 | 1 | 120 | 1.15385 |
| 15 | 329 | 600 | 190 | 7 | 520 | 17 | 1 | 105 | 1.15385 |
| 16 | 381 | 608 | 313 | 7 | 520 | 17 | 1 | 210 | 1.16923 |
| 17 | 151 | 609 | 1 | 7 | 520 | 87 | 0 | 0 | 1.17115 |
| 18 | 331 | 610 | 210 | 7 | 520 | 21 | 1 | 250 | 1.17308 |
| 19 | 459 | 610 | 372 | 7 | 520 | 14 | 1 | 240 | 1.17308 |
| 20 | 324 | 615 | 259 | 7 | 520 | 9 | 0 | 0 | 1.18269 |
| 21 | 337 | 620 | 213 | 7 | 520 | 43 | 1 | 315 | 1.19231 |
| 22 | 316 | 623 | 236 | 7 | 520 | 20 | 0 | 0 | 1.19808 |
| 23 | 294 | 626 | 183 | 7 | 520 | 20 | 1 | 130 | 1.20385 |
| 24 | 362 | 634 | 277 | 7 | 520 | 27 | 1 | 300 | 1.21923 |
| 25 | 260 | 644 | 92 | 7 | 520 | 17 | 0 | 0 | 1.23846 |
| 26 | 447 | 649 | 373 | 7 | 520 | 27 | 1 | 240 | 1.24808 |
| 27 | 341 | 649 | 263 | 7 | 520 | 27 | 0 | 0 | 1.24808 |
| 28 | 321 | 651 | 246 | 7 | 520 | 20 | 1 | 205 | 1.25192 |
| 29 | 386 | 652 | 323 | 7 | 520 | 20 | 0 | 0 | 1.25385 |
| 30 | 420 | 658 | 341 | 7 | 520 | 65 | 1 | 375 | 1.26538 |
| 31 | 345 | 666 | 272 | 7 | 520 | 43 | 1 | 180 | 1.28077 |
| 32 | 258 | 675 | 128 | 7 | 520 | 20 | 1 | 100 | 1.29808 |
| 33 | 334 | 680 | 204 | 7 | 520 | 11 | 0 | 0 | 1.30769 |
| 34 | 351 | 692 | 270 | 7 | 520 | 17 | 1 | 180 | 1.33077 |
| 35 | 595 | 697 | 527 | 7 | 520 | 65 | 1 | 465 | 1.34038 |
| 36 | 341 | 764 | 170 | 7 | 520 | 22 | 1 | 360 | 1.46923 |
| 37 | 345 | 812 | 153 | 7 | 520 | 22 | 1 | 180 | 1.56154 |
| 38 | 290 | 812 | 130 | 7 | 520 | 9 | 0 | 0 | 1.56154 |
| 39 | 413 | 842 | 264 | 7 | 520 | 87 | 0 | 0 | 1.61923 |
| 40 | 349 | 844 | 127 | 7 | 520 | 22 | 0 | 0 | 1.62308 |

| No | TT | CD | CT | Link ID | Link Length | Vehicle | InT | InD | Ratio |
|----|-----|-----|-----|---------|-------------|---------|-----|-----|---------|
| 41 | 329 | 732 | 244 | 8 | 660 | 16 | 1 | 312 | 1.10909 |
| 42 | 300 | 788 | 175 | 8 | 660 | 27 | 0 | 0 | 1.19394 |
| 43 | 624 | 807 | 537 | 8 | 660 | 43 | 1 | 106 | 1.22273 |
| 44 | 594 | 968 | 1 | 8 | 660 | 65 | 0 | 0 | 1.46667 |
| 45 | 316 | 958 | 112 | 9 | 856 | 17 | 0 | 0 | 1.11785 |
| 46 | 306 | 971 | 148 | 9 | 856 | 43 | 1 | 180 | 1.13302 |
| 47 | 98 | 447 | 4 | 10 | 403 | 43 | 0 | 0 | 1.10918 |
| 48 | 110 | 448 | 2 | 10 | 403 | 80 | 0 | 0 | 1.11166 |
| 49 | 122 | 448 | 4 | 10 | 403 | 19 | 0 | 0 | 1.11166 |
| 50 | 85 | 449 | 2 | 10 | 403 | 10 | 0 | 0 | 1.11414 |
| 51 | 114 | 455 | 26 | 10 | 403 | 13 | 0 | 0 | 1.12903 |
| 52 | 76 | 456 | 2 | 10 | 403 | 66 | 0 | 0 | 1.13151 |
| 53 | 139 | 456 | 43 | 10 | 403 | 92 | 0 | 0 | 1.13151 |
| 54 | 114 | 462 | 68 | 10 | 403 | 87 | 0 | 0 | 1.14640 |
| 55 | 91 | 466 | 4 | 10 | 403 | 23 | 0 | 0 | 1.15633 |
| 56 | 103 | 476 | 5 | 10 | 403 | 17 | 0 | 0 | 1.18114 |
| 57 | 287 | 477 | 237 | 10 | 403 | 16 | 4 | 120 | 1.18362 |
| 58 | 96 | 479 | 1 | 10 | 403 | 66 | 0 | 0 | 1.18859 |
| 59 | 137 | 488 | 44 | 10 | 403 | 23 | 0 | 0 | 1.21092 |
| 60 | 110 | 489 | 4 | 10 | 403 | 13 | 0 | 0 | 1.21340 |
| 61 | 92 | 501 | 2 | 10 | 403 | 14 | 0 | 0 | 1.24318 |
| 62 | 162 | 510 | 44 | 10 | 403 | 22 | 1 | 60 | 1.26551 |
| 63 | 91 | 514 | 4 | 10 | 403 | 10 | 0 | 0 | 1.27543 |
| 64 | 104 | 515 | 1 | 10 | 403 | 40 | 0 | 0 | 1.27792 |
| 65 | 107 | 521 | 8 | 10 | 403 | 17 | 0 | 0 | 1.29280 |
| 66 | 147 | 548 | 48 | 10 | 403 | 27 | 6 | 60 | 1.35980 |
| 67 | 112 | 553 | 14 | 10 | 403 | 13 | 1 | 60 | 1.37221 |
| 68 | 93 | 564 | 1 | 10 | 403 | 10 | 0 | 0 | 1.39950 |
| 69 | 108 | 570 | 8 | 10 | 403 | 21 | 0 | 0 | 1.41439 |
| 70 | 104 | 576 | 2 | 10 | 403 | 13 | 0 | 0 | 1.42928 |
| 71 | 106 | 597 | 2 | 10 | 403 | 17 | 0 | 0 | 1.48139 |
| 72 | 109 | 607 | 1 | 10 | 403 | 9 | 0 | 0 | 1.50620 |
| 73 | 155 | 648 | 58 | 10 | 403 | 17 | 0 | 0 | 1.60794 |
| 74 | 230 | 668 | 70 | 10 | 403 | 65 | 0 | 0 | 1.65757 |
| 75 | 647 | 707 | 604 | 10 | 403 | 43 | 4 | 540 | 1.75434 |
| 76 | 292 | 735 | 241 | 10 | 403 | 87 | 4 | 243 | 1.82382 |
| 77 | 87 | 511 | 2 | 11 | 457 | 17 | 0 | 0 | 1.11816 |
| 78 | 154 | 511 | 107 | 11 | 457 | 65 | 1 | 60 | 1.11816 |
| 79 | 140 | 529 | 29 | 11 | 457 | 65 | 0 | 0 | 1.15755 |
| 80 | 181 | 552 | 62 | 11 | 457 | 21 | 0 | 0 | 1.20788 |

| No | TT | CD | CT | Link ID | Link Length | Vehicle | InT | InD | Ratio |
|----|-----|-----|-----|---------|-------------|---------|-----|-----|---------|
| 81 | 165 | 612 | 55 | 11 | 457 | 17 | 5 | 60 | 1.33917 |
| 82 | 322 | 460 | 260 | 31 | 403 | 22 | 0 | 0 | 1.14144 |
| 83 | 160 | 466 | 46 | 31 | 403 | 9 | 4 | 65 | 1.15633 |
| 84 | 399 | 485 | 341 | 31 | 403 | 16 | 0 | 0 | 1.20347 |
| 85 | 676 | 491 | 639 | 31 | 403 | 17 | 4 | 510 | 1.21836 |
| 86 | 93 | 502 | 1 | 31 | 403 | 13 | 0 | 0 | 1.24566 |
| 87 | 170 | 507 | 68 | 31 | 403 | 27 | 0 | 0 | 1.25806 |
| 88 | 227 | 510 | 145 | 31 | 403 | 16 | 0 | 0 | 1.26551 |
| 89 | 118 | 527 | 14 | 31 | 403 | 20 | 0 | 0 | 1.30769 |
| 90 | 131 | 535 | 25 | 31 | 403 | 92 | 0 | 0 | 1.32754 |
| 91 | 103 | 543 | 3 | 31 | 403 | 20 | 0 | 0 | 1.34739 |
| 92 | 638 | 548 | 508 | 31 | 403 | 43 | 0 | 0 | 1.35980 |
| 93 | 384 | 611 | 351 | 31 | 403 | 22 | 5 | 60 | 1.51613 |
| 94 | 132 | 469 | 87 | 32 | 403 | 16 | 4 | 85 | 1.16377 |
| 95 | 247 | 528 | 210 | 32 | 403 | 17 | 4 | 240 | 1.31017 |

Table 23: Distribution of Travel-Time Differences (in seconds): Link 1

| | Difference | No. of Reports | % of Total Reports |
|-------|------------|----------------|--------------------|
| | -5 | 0 | 0 |
| | -4 | 1 | 1.4 |
| | -3 | 2 | 2.7 |
| | -2 | 3 | 4.1 |
| | -1 | 7 | 9.5 |
| | 0 | 7 | 9.5 |
| | +1 | 15 | 20.3 |
| | +2 | 15 | 20.3 |
| | +3 | 7 | 9.5 |
| | +4 | 5 | 6.8 |
| | +5 | 2 | 2.7 |
| Total | | | 86.8 |

Table 24: Distribution of Travel-Time Differences (in seconds): Link 2

| | Difference | No. of Reports | % of Total Reports |
|-------|------------|----------------|--------------------|
| | -5 | 2 | 2.8 |
| | -4 | 6 | 8.3 |
| | -3 | 6 | 8.3 |
| | -2 | 13 | 18.1 |
| | -1 | 11 | 15.3 |
| | 0 | 10 | 13.9 |
| | +1 | 6 | 8.3 |
| | +2 | 4 | 5.6 |
| | +3 | 5 | 6.9 |
| | +4 | 1 | 1.4 |
| | +5 | 0 | 0 |
| Total | | | 88.9 |

Table 25: Distribution of Travel-Time Differences (in seconds): Link 3

| | Difference | No. of Reports | % of Total Reports |
|-------|------------|----------------|--------------------|
| | -5 | 3 | 4.3 |
| | -4 | 3 | 4.3 |
| | -3 | 3 | 4.3 |
| | -2 | 2 | 2.9 |
| | -1 | 14 | 20 |
| | 0 | 10 | 14.3 |
| | +1 | 9 | 12.9 |
| | +2 | 6 | 8.6 |
| | +3 | 6 | 8.6 |
| | +4 | 5 | 7.1 |
| | +5 | 3 | 4.3 |
| Total | | | 91.6 |

Table 26: Distribution of Travel-Time Differences (in seconds): Link 4

| | Difference | No. of Reports | % of Total Reports |
|-------|------------|----------------|--------------------|
| | -5 | 2 | 3.7 |
| | -4 | 3 | 5.6 |
| | -3 | 2 | 3.7 |
| | -2 | 3 | 5.6 |
| | -1 | 2 | 3.7 |
| | 0 | 12 | 22.2 |
| | +1 | 9 | 16.7 |
| | +2 | 7 | 13.0 |
| | +3 | 6 | 11.1 |
| | +4 | 4 | 7.4 |
| | +5 | 2 | 3.7 |
| Total | | | 96.4 |

Table 27: Distribution of Travel-Time Differences (in seconds): Link 5

| | Difference | No. of Reports | % of Total Reports |
|-------|------------|----------------|--------------------|
| | -5 | 2 | 3.5 |
| | -4 | 2 | 3.5 |
| | -3 | 6 | 10.5 |
| | -2 | 9 | 15.8 |
| | -1 | 12 | 21.1 |
| | 0 | 10 | 17.5 |
| | +1 | 3 | 5.3 |
| | +2 | 4 | 7.0 |
| | +3 | 2 | 3.5 |
| | +4 | 2 | 3.5 |
| | +5 | 1 | 1.8 |
| Total | | | 93.0 |

Table 28: Distribution of Travel-Time Differences (in seconds): Link 6

| | Difference | No. of Reports | % of Total Reports |
|-------|------------|----------------|--------------------|
| | -5 | 1 | 1.6 |
| | -4 | 2 | 3.3 |
| | -3 | 2 | 3.3 |
| | -2 | 8 | 13.1 |
| | -1 | 15 | 24.6 |
| | 0 | 8 | 13.1 |
| | +1 | 5 | 8.2 |
| | +2 | 5 | 8.2 |
| | +3 | 3 | 4.9 |
| | +4 | 3 | 4.9 |
| | +5 | 0 | 0 |
| Total | | | 85.2 |

Table 29: Distribution of Travel-Time Differences (in seconds): Link 7

| | Difference | No. of Reports | % of Total Reports |
|-------|------------|----------------|--------------------|
| | -5 | 1 | 1.6 |
| | -4 | 0 | 0 |
| | -3 | 0 | 0 |
| | -2 | 2 | 3.2 |
| | -1 | 4 | 6.5 |
| | 0 | 4 | 6.5 |
| | +1 | 9 | 14.5 |
| | +2 | 10 | 16.1 |
| | +3 | 8 | 12.9 |
| | +4 | 7 | 11.3 |
| | +5 | 4 | 6.5 |
| Total | | | 79.1 |

Table 30: Distribution of Travel-Time Differences (in seconds): Link 8

| | Difference | No. of Reports | % of Total Reports |
|-------|------------|----------------|--------------------|
| | -5 | 4 | 7.7 |
| | -4 | 2 | 3.8 |
| | -3 | 3 | 5.8 |
| | -2 | 7 | 13.5 |
| | -1 | 9 | 17.3 |
| | 0 | 7 | 13.5 |
| | +1 | 5 | 9.6 |
| | +2 | 3 | 5.8 |
| | +3 | 1 | 1.9 |
| | +4 | 1 | 1.9 |
| | +5 | 0 | 0 |
| Total | | | 80.8 |

Table 31: Distribution of Travel-Time Differences (in seconds): Link 9

| | Difference | No. of Reports | % of Total Reports |
|-------|------------|----------------|--------------------|
| | -5 | 2 | 3.8 |
| | -4 | 3 | 5.7 |
| | -3 | 4 | 7.5 |
| | -2 | 11 | 20.8 |
| | -1 | 9 | 17.0 |
| | 0 | 1 | 1.9 |
| | +1 | 3 | 5.7 |
| | +2 | 3 | 5.7 |
| | +3 | 2 | 3.8 |
| | +4 | 3 | 5.7 |
| | +5 | 3 | 5.7 |
| Total | | | 83.3 |

Table 32: Distribution of Travel-Time Differences (in seconds): Link 10

| | Difference | No. of Reports | % of Total Reports |
|-------|------------|----------------|--------------------|
| | -5 | 0 | 0 |
| | -4 | 1 | 1.4 |
| | -3 | 3 | 4.2 |
| | -2 | 7 | 9.9 |
| | -1 | 5 | 7.0 |
| | 0 | 11 | 15.5 |
| | +1 | 7 | 9.9 |
| | +2 | 12 | 16.9 |
| | +3 | 10 | 14.1 |
| | +4 | 3 | 4.2 |
| | +5 | 2 | 2.8 |
| Total | | | 85.9 |

Table 33: Distribution of Travel-Time Differences (in seconds): Link 11

| | Difference | No. of Reports | % of Total Reports |
|-------|------------|----------------|--------------------|
| | -5 | 2 | 2.6 |
| | -4 | 2 | 2.6 |
| | -3 | 6 | 7.9 |
| | -2 | 8 | 10.5 |
| | -1 | 9 | 11.8 |
| | 0 | 12 | 15.8 |
| | +1 | 15 | 19.7 |
| | +2 | 4 | 5.3 |
| | +3 | 10 | 13.2 |
| | +4 | 1 | 1.3 |
| | +5 | 1 | 1.3 |
| Total | | | 92.0 |

Table 34: Distribution of Travel-Time Differences (in seconds): Link 12

| | Difference | No. of Reports | % of Total Reports |
|-------|------------|----------------|--------------------|
| | -5 | 1 | 1.4 |
| | -4 | 1 | 1.4 |
| | -3 | 2 | 2.7 |
| | -2 | 0 | 0 |
| | -1 | 8 | 10.8 |
| | 0 | 9 | 12.2 |
| | +1 | 16 | 21.6 |
| | +2 | 7 | 9.5 |
| | +3 | 13 | 17.6 |
| | +4 | 5 | 6.8 |
| | +5 | 3 | 4.1 |
| Total | | | 88.1 |

Table 35: Distribution of Travel-Time Differences: Vehicle 10

| | Difference | No. of Reports | % of Total Reports |
|-------|------------|----------------|--------------------|
| | -5 | 2 | 1.9 |
| | -4 | 2 | 1.9 |
| | -3 | 6 | 5.8 |
| | -2 | 10 | 9.6 |
| | -1 | 17 | 16.3 |
| | 0 | 12 | 11.5 |
| | +1 | 13 | 12.5 |
| | +2 | 10 | 9.6 |
| | +3 | 12 | 11.5 |
| | +4 | 5 | 4.8 |
| | +5 | 1 | 1.0 |
| Total | | | 86.4 |

Table 36: Distribution of Travel-Time Differences: Vehicle 11

| | Difference | No. of Reports | % of Total Reports |
|-------|------------|----------------|--------------------|
| | -5 | 1 | 4.2 |
| | -4 | 0 | 0 |
| | -3 | 0 | 0 |
| | -2 | 0 | 0 |
| | -1 | 4 | 16.7 |
| | 0 | 4 | 16.7 |
| | +1 | 1 | 4.2 |
| | +2 | 0 | 0 |
| | +3 | 4 | 16.7 |
| | +4 | 1 | 4.2 |
| | +5 | 0 | 0 |
| Total | | | 62.7 |

Table 37: Distribution of Travel-Time Differences: Vehicle 13

| | Difference | No. of Reports | % of Total Reports |
|-------|------------|----------------|--------------------|
| | -5 | 2 | 3.1 |
| | -4 | 3 | 4.7 |
| | -3 | 3 | 4.7 |
| | -2 | 5 | 7.8 |
| | -1 | 12 | 18.8 |
| | 0 | 7 | 10.9 |
| | +1 | 14 | 21.9 |
| | +2 | 4 | 6.3 |
| | +3 | 4 | 6.3 |
| | +4 | 1 | 1.6 |
| | +5 | 2 | 3.1 |
| Total | | | 89.2 |

Table 38: Distribution of Travel-Time Differences: Vehicle 16

| | Difference | No. of Reports | % of Total Reports |
|-------|------------|----------------|--------------------|
| | -5 | 1 | 2.1 |
| | -4 | 3 | 6.4 |
| | -3 | 3 | 6.4 |
| | -2 | 5 | 10.6 |
| | -1 | 1 | 2.1 |
| | 0 | 6 | 12.8 |
| | +1 | 6 | 12.8 |
| | +2 | 6 | 12.8 |
| | +3 | 4 | 8.5 |
| | +4 | 4 | 8.5 |
| | +5 | 1 | 2.1 |
| Total | | | 85.1 |

Table 39: Distribution of Travel-Time Differences: Vehicle 17

| | Difference | No. of Reports | % of Total Reports |
|-------|------------|----------------|--------------------|
| | -5 | 2 | 3.9 |
| | -4 | 1 | 2.0 |
| | -3 | 4 | 7.8 |
| | -2 | 5 | 9.8 |
| | -1 | 6 | 11.8 |
| | 0 | 6 | 11.8 |
| | +1 | 10 | 19.8 |
| | +2 | 7 | 13.7 |
| | +3 | 6 | 11.8 |
| | +4 | 1 | 2.0 |
| | +5 | 2 | 3.9 |
| Total | | | 98.1 |

Table 40: Distribution of Travel-Time Differences: Vehicle 20

| | Difference | No. of Reports | % of Total Reports |
|-------|------------|----------------|--------------------|
| | -5 | 1 | 1.2 |
| | -4 | 1 | 1.2 |
| | -3 | 5 | 6.2 |
| | -2 | 6 | 7.4 |
| | -1 | 14 | 17.3 |
| | 0 | 14 | 17.3 |
| | +1 | 9 | 11.1 |
| | +2 | 9 | 11.1 |
| | +3 | 4 | 4.9 |
| | +4 | 4 | 4.9 |
| | +5 | 3 | 3.7 |
| Total | | | 86.3 |

Table 41: Distribution of Travel-Time Differences: Vehicle 21

| | Difference | No. of Reports | % of Total Reports |
|-------|------------|----------------|--------------------|
| | -5 | 1 | 2.7 |
| | -4 | 1 | 2.7 |
| | -3 | 3 | 8.1 |
| | -2 | 2 | 5.4 |
| | -1 | 3 | 8.1 |
| | 0 | 1 | 2.7 |
| | +1 | 4 | 10.8 |
| | +2 | 3 | 8.1 |
| | +3 | 4 | 10.8 |
| | +4 | 3 | 8.1 |
| | +5 | 0 | 0 |
| Total | | | 67.5 |

Table 42: Distribution of Travel-Time Differences: Vehicle 23

| | Difference | No. of Reports | % of Total Reports |
|-------|------------|----------------|--------------------|
| | -5 | 1 | 2.0 |
| | -4 | 2 | 4.1 |
| | -3 | 2 | 4.1 |
| | -2 | 4 | 8.2 |
| | -1 | 8 | 16.3 |
| | 0 | 7 | 14.3 |
| | +1 | 6 | 12.2 |
| | +2 | 4 | 8.2 |
| | +3 | 5 | 10.2 |
| | +4 | 3 | 6.1 |
| | +5 | 4 | 8.2 |
| Total | | | 93.9 |

Table 43: Distribution of Travel-Time Differences: Vehicle 27

| | Difference | No. of Reports | % of Total Reports |
|-------|------------|----------------|--------------------|
| | -5 | 2 | 1.8 |
| | -4 | 4 | 3.6 |
| | -3 | 3 | 2.7 |
| | -2 | 21 | 19.1 |
| | -1 | 12 | 11.8 |
| | 0 | 16 | 14.5 |
| | +1 | 15 | 13.6 |
| | +2 | 16 | 14.5 |
| | +3 | 11 | 10.0 |
| | +4 | 7 | 6.4 |
| | +5 | 2 | 1.8 |
| Total | | | 100 |

Table 44: Distribution of Travel-Time Differences: Vehicle 43

| | Difference | No. of Reports | % of Total Reports |
|-------|------------|----------------|--------------------|
| | -5 | 0 | 0 |
| | -4 | 3 | 6.4 |
| | -3 | 0 | 0 |
| | -2 | 4 | 8.5 |
| | -1 | 9 | 19.1 |
| | 0 | 7 | 14.9 |
| | +1 | 4 | 8.5 |
| | +2 | 6 | 12.8 |
| | +3 | 7 | 14.9 |
| | +4 | 1 | 2.1 |
| | +5 | 3 | 6.4 |
| Total | | | 93.6 |

Table 45: Distribution of Travel-Time Differences: Vehicle 65

| | Difference | No. of Reports | % of Total Reports |
|-------|------------|----------------|--------------------|
| | -5 | 2 | 3.8 |
| | -4 | 2 | 3.8 |
| | -3 | 2 | 3.8 |
| | -2 | 5 | 9.6 |
| | -1 | 6 | 11.5 |
| | 0 | 8 | 15.4 |
| | +1 | 5 | 9.6 |
| | +2 | 5 | 9.6 |
| | +3 | 6 | 11.5 |
| | +4 | 4 | 7.7 |
| | +5 | 3 | 5.8 |
| Total | | | 92.1 |

Table 46: Distribution of Travel-Time Differences: Vehicle 87

| | Difference | No. of Reports | % of Total Reports |
|-------|------------|----------------|--------------------|
| | -5 | 5 | 4.5 |
| | -4 | 4 | 3.6 |
| | -3 | 8 | 7.3 |
| | -2 | 6 | 5.5 |
| | -1 | 12 | 10.9 |
| | 0 | 13 | 11.8 |
| | +1 | 15 | 13.6 |
| | +2 | 10 | 9.1 |
| | +3 | 6 | 5.5 |
| | +4 | 6 | 5.5 |
| | +5 | 0 | 0 |
| Total | | | 77.3 |



APPENDIX D

ADVANCE

**Advanced Driver and Vehicle
Advisory Navigation Concept**

Traffic Related Functions
Evaluation Report (4 of 7)
Documents # 8460.00

CONTAINS:

| | |
|--|--------------------------|
| Base Data and Static Profile Evaluation Report | -- Document # 8460-01.01 |
| Data Screening Evaluation Report | -- Document # 8460-02.02 |
| Quality of Probe Reports Evaluation Report | -- Document # 8460-03.01 |
| • Travel Time Prediction and Performance of Probe and Detector Data Evaluation Report | -- Document # 8460-04.01 |
| Detector Travel Time Conversion and Fusion of Probe and Detector Data Evaluation Report | -- Document # 8460-05.01 |
| Frequency of Probe Reports Evaluation Report | -- Document # 8460-06.01 |
| Relationships among Travel Times Evaluation Report | -- Document # 8460-07.02 |

Prepared by
University of Illinois-Chicago
Urban Transportation Center

DISCLAIMER

This report was prepared by a contractor for
Argonne National Laboratory
and is published as it was received.

ADVANCE Evaluation
Travel Time Prediction and
Performance of Probe and Detector
Data

Ashish Sen, Siim Sööt, Xin Tian
and Helen Condie

URBAN TRANSPORTATION CENTER
University of Illinois at Chicago
1033 West Van Buren Street
Suite 700 South
Chicago, Illinois 60607

September 1996

Executive Summary

During the summer of 1995 eight to fifteen vehicles per day were deployed to examine the performance of the travel-time prediction (TTP) algorithm. Two study routes comprising a total of thirteen links were driven. Two of the three links with volume-occupancy detectors were selected for detailed examination. TTP estimates and probe reports were also compared on two links which did not have detector data. In the detectorized and non-detectorized cases one of the links we focused on was highly congested during the peak period while the other experienced less congestion. This provides a mix of information and conditions which provides a reasonable overview of the TTP algorithm.

Both detector and probe data performed well during the off-peak period. During the peak period the occupancy detectors quickly became saturated and yielded unreliable travel-time predictions. The probe-based predictions were better but during the peak periods substantially underestimated actual travel times. This reflects the decision made in the development of the algorithm (to use a conservative algorithm) and this study suggests that the algorithm be adjusted to reflect these underestimations. In a subsequent deployment this adjustment can be made and the algorithm will produce more accurate predictions. The present algorithm, however, performs exceptionally well when there are a few outliers among the travel times recorded during a five-minute study interval. These aberrations are largely ignored by the TTP, as indeed they should be. Lastly, the number of probe reports during five-minute intervals represent the input to the TTP process and intervals with four and more probe reports are examined to determine the effect on travel-time prediction of randomly decreasing the number of probe reports. This analysis suggests that in most instances three probe reports are adequate to provide reasonable TTPs. With an increasing number of probe reports beyond three the TTPs change very little.

Contents

| | |
|---|-----------|
| Executive Summary | i |
| 1 Introduction | 1 |
| 2 TTP Algorithm | 1 |
| 2.1 Background | 1 |
| 2.2 Data Inputs | 3 |
| 2.3 On-Line TTP Procedure | 5 |
| 3 Data Collection and Reduction | 5 |
| 3.1 Probe-Vehicle Reports | 5 |
| 3.1.1 Data-Collection Routes | 5 |
| 3.1.2 Data-Collection Schedule | 7 |
| 3.1.3 Data Processing and Reduction | 7 |
| 3.2 Detector-Data Reports | 9 |
| 3.2.1 Data Collection | 9 |
| 3.2.2 Data Processing and Reduction | 10 |
| 4 Travel-Time Prediction | 11 |
| 4.1 Predicted and Actual Travel Times | 11 |
| 4.2 Prediction Algorithm | 11 |
| 5 Results of TTP Evaluation | 14 |
| 5.1 Selection of Links for Evaluation | 14 |
| 5.2 Probe Data Only | 14 |
| 5.2.1 Link 2: Less Congested | 14 |
| 5.2.2 Link 9: Congested | 19 |
| 5.3 Detector Data Only | 23 |
| 5.3.1 Link 11: Less Congested | 23 |
| 5.3.2 Link 7: Congested | 23 |
| 5.4 Fused Probe and Detector Data | 26 |
| 5.4.1 Link 11: Less Congested | 26 |
| 5.4.2 Link 7: Congested | 26 |
| 5.5 Probe Data Only at Varying Deployment Levels | 29 |
| 5.5.1 Current Travel-Time Estimates | 29 |
| 5.5.2 Five-Minute Forecasts | 30 |
| 5.5.3 Ten-Minute Forecasts | 30 |
| 5.5.4 Fifteen-Minute Forecasts | 30 |
| 5.5.5 Overview of Varying Number of Probe Reports | 35 |
| 6 Conclusion | 38 |

List of Figures

| | | |
|----|---|----|
| 1 | Data Flow of Travel-Time Prediction in ADVANCE | 2 |
| 2 | Data Flow of Active Travel Time Prediction in ADVANCE | 4 |
| 3 | Probe-Data Collection: Dundee Road Routes | 6 |
| 4 | Location of Loop Detectors Used in Data Collection. (A through E represent in-ground detector locations.) | 9 |
| 5 | Individual Probe Travel Times and Probe-Only Estimates by Time Interval: Link 2, July 20 | 13 |
| 6 | Individual Probe Travel Times and Probe-Only Estimates by Time Interval: Link 2, July 18 | 15 |
| 7 | Probe Travel Times Plotted against Estimated and Forecast Travel Times: Link 2, July 17 | 17 |
| 8 | Five-Minute Mean Probe Travel Times and Probe-Only Estimates by Time Interval: Link 2, July 17 | 18 |
| 9 | Individual Probe Travel Times and Probe-Only Estimates by Time Interval: Link 9, July 19 | 20 |
| 10 | Probe Travel Times Plotted against Estimated and Forecast Travel Times: Link 9, July 19 | 21 |
| 11 | Five-Minute Mean Probe Travel Times and Probe-Only Estimates by Time Interval: Link 9, July 19 | 22 |
| 12 | Individual Probe Travel Times and Detector-Only and Probe-Only Estimates: Link 11, July 17 | 24 |
| 13 | Individual Probe Travel Times and Detector-Only and Probe-Only Estimates: Link 7, July 18 | 25 |
| 14 | Individual Probe Travel Times and Estimates based on Fused Probe and Detector Data: Link 11, July 17 | 27 |
| 15 | Individual Probe Travel Times and Estimates based on Fused Probe and Detector Data: Link 7, July 18 | 28 |
| 16 | Individual Probe Travel Times and Current Estimates with Varying Numbers of Probe Reports: Link 7, July 18 | 31 |
| 17 | Individual Probe Travel Times and Five-Minute Forecasts with Varying Numbers of Probe Reports: Link 7, July 18 | 32 |
| 18 | Individual Probe Travel Times and Ten-Minute Forecasts with Varying Numbers of Probe Reports: Link 7, July 18 | 33 |
| 19 | Individual Probe Travel Times and Fifteen-Minute Forecasts with Varying Numbers of Probe Reports: Link 7, July 18 | 34 |

List of Tables

| | | |
|---|--|----|
| 1 | Probe Reports for each day of Data Collection | 8 |
| 2 | Sample of Reduced Data Output | 10 |
| 3 | Travel-Time Estimates for 5-minute Periods with 4 or more Probe Reports: Link 7, July 18 | 36 |

1 Introduction

This report summarizes an evaluation of the quality of output received from the Travel-Time Prediction (TTP) Algorithm. In basic terms, the algorithm uses probe (vehicle) and detector data, as run through several sub-processes, to develop travel-time predictions for specific links and for specific time intervals. The overall TTP process uses the results of several other procedures which provide it with the necessary data inputs.

In practice, the Traffic Information Center (TIC) accumulates probe and detector data for a five-minute period, having obtained the probe data via RF from probe vehicles. The TIC uses these data to estimate the current travel time as well as the five-minute travel-time predictions (TTPs) for the next fifteen minute period, using an algorithm constructed as part of TRF.

In this report we evaluate the *current estimates* as well as the *TTPs*. The *current estimates* are constructed using an algorithm in Data Fusion and the *TTPs* are constructed using algorithms in the TTP task.

This report compares the TTPs with individual probe reports and with five-minute travel-time means. The report first presents the results of analysis using probe data only then using detector data only and finally focuses on the TTP output using both detector and probe data. In the evaluation using probe-data only the level of probe input is randomly decreased to determine how the quality of TTPs deteriorates with decreasing probe input.

2 TTP Algorithm

2.1 Background

This report concerns an evaluation of the performance of the TTP algorithm in predicting link travel times, and does not present an exhaustive explanation of the algorithm, which has been documented elsewhere (see Liu and Sen, 1995). This section will introduce the reader to the algorithm, its objectives, and its components. The TTP procedure is shown in Figure 1. While the figure (taken from the report referenced above) as shown indicates that the entire TTP process includes *Outbound Broadcast Prioritization*, this additional process will not be implemented and is therefore not discussed further in this document.

TTP is a dynamic process in which travel-time estimates for specific links and time periods are constructed using processed data; this procedure is differentiated from a static procedure. When fully developed, the Mobile Navigation Assistant (MNA) will contain a database of expected link travel times called Static Profiles (SP) for each time period. These estimates are the basis on which the MNA makes the calculations for expected trip travel times. TTP acts as a comparison to these fixed numbers. As probes traverse the links, the MNAs and detectors (if the link is detectorized) constantly feed data to the TIC which then processes that data into estimated link

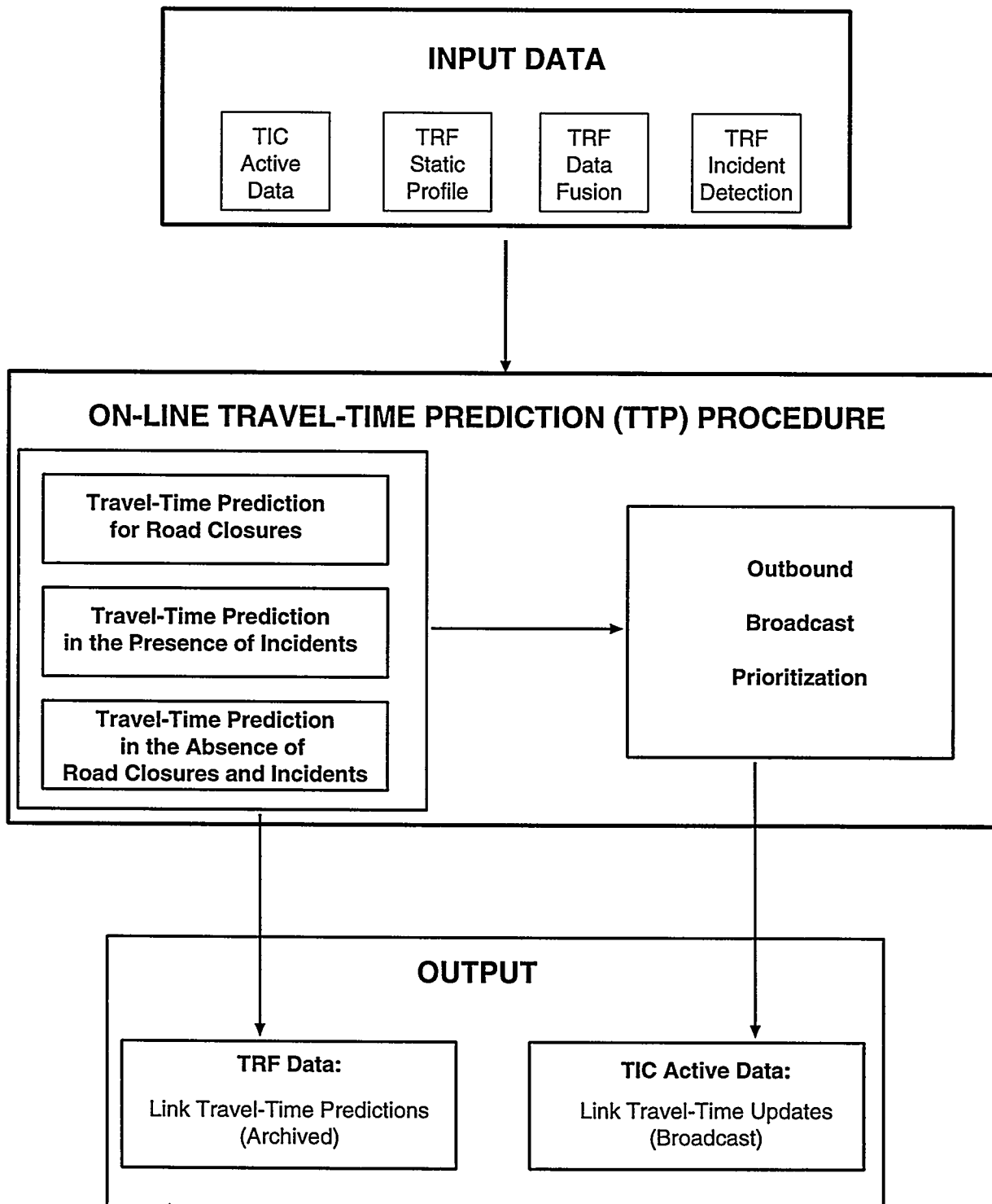

Figure 1: Data Flow of Travel-Time Prediction in ADVANCE

travel times (see Section 2.2). The final output of these procedures is then compared to the SP expected travel time. If the actively-determined travel time differs from the static profile by more than twenty seconds, the TTP program overrides the SP and uses the actively-determined travel-time estimate to determine the most efficient route. In essence, TTP enables the MNA to propose the most efficient route under current travel conditions, using both static and dynamic estimates. Note that data fusion is only performed if the link under question is detectorized; if it is not, detector travel time conversion (DTTC) cannot be performed and the active travel-time estimate is based on probe data alone.

2.2 Data Inputs

An overview of the process by which TTPs are computed is shown in Figure 2. If a link is detectorized, fused data based both on detectors and probes are used in the TTP process — or in estimating the current travel-time estimates. If a link is not detectorized, probe data alone are used. Either way, static profiles (which are essentially averages over different days of link travel times) are subtracted from these estimates and the differences are broadcast if their absolute value exceeds 20 seconds and if no incidents or road closures are indicated. In the ADVANCE design a more complex method was described in order to determine which differences were to be broadcast; this method was not appropriate for targeted deployment and the 20-second rule just mentioned was used instead. If an incident flag is ‘on’ or if there is road closure then the TTP minus static estimate times are not broadcast. Instead, other estimates obtained from ID (Incident Detection) under incident conditions, or in the case of known lane or road closures, are broadcast.

While in the actual deployment of ADVANCE, for each time period, each link and each forecast period (current, 5, 10 or 15 minutes into the future) a single time estimate is generated, in this evaluation we take advantage of a very rich data source to ask a number of ‘what if’ questions. In particular, we ask the following questions:

- How good are travel-time estimates when detector data is not available and only probe data is used?
- How good are travel-time estimates when no probes are available and only detector data is used?
- How good are travel-time estimates when fused probe and detector data is used?
- What is the effect of using different numbers of probe reports per time interval when only probe data is used?

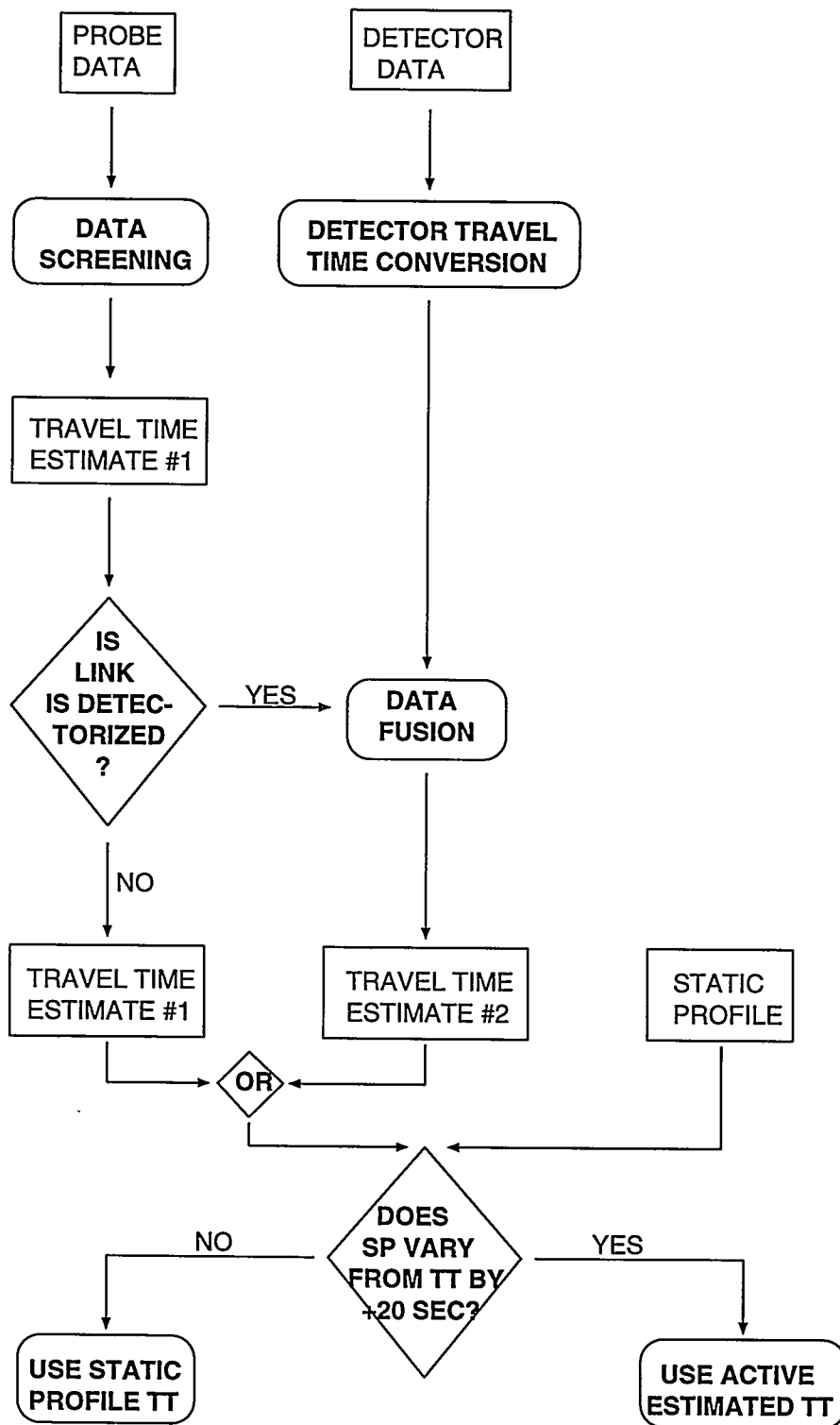

Figure 2: Data Flow of Active Travel Time Prediction in ADVANCE

2.3 On-Line TTP Procedure

The TTP algorithm is run three times, once for probe data only, once for detector data only, and the third time using the fused probe and detector data. In addition, the two runs that use probe data are run several times at Deployment Levels 1, 2, 3 and 4; the deployment level refers to the number of probe reports randomly selected and utilized to compute the average travel-time values for a given link in that five-minute interval. Five-minute intervals are used because detectors only transmit data in five-minute intervals. Both detector and probe data are assembled into five-minute intervals.

3 Data Collection and Reduction

In this section we discuss the collection of probe-vehicle data and detector data.

3.1 Probe-Vehicle Reports

Data used in the TTP processes were collected during the summer of 1995, when up to fifteen probe-equipped vehicles were driven four days a week over an eleven-week period. During this time almost 60,000 miles were driven to produce over 50,000 link reports within a defined study area. These reports provide information on at least three critical elements of travel: travel time, congested time and congested distance. This information is computed in the vehicle in its on-board MNA and is recorded in two different ways, in the vehicle (on memory cards, which are similar to computer diskettes) and as sent by radio frequency (RF) to files tabulated at the Traffic Information Center (TIC) in Schaumburg, Illinois.

3.1.1 Data-Collection Routes

Data were collected on several study routes from June 5th to August 10th, Monday through Thursday. The original ADVANCE project design called for a massive probe deployment covering scores of routes with thousands of cars. This original version was scaled back; the overall evaluation uses data gathered from a targeted deployment of between eight to fifteen cars per day over short, defined study routes. The evaluation of TTP uses data from a one-week period when we had at least twelve probe vehicles per day. To simulate full deployment, the probes were driven repeatedly over two short study routes, thereby creating for each link a database of commensurate size to that of the original design. The entire routes driven on Dundee Road and adjacent arterials are within the municipality of Wheeling, Illinois (north suburban Chicago). Dundee Road was selected for the routes because it carries a high volume of traffic and because each signalized intersection is demand actuated by loop detectors (including turning lanes). In addition to the loop detectors at signalized intersections, there are volume

and occupancy detectors on three links. Although Dundee Road extends for several miles within the greater ADVANCE study area, the number of potential places along Dundee Road where the necessary field tests could be performed was very limited. However, because Dundee Road is the only arterial within the ADVANCE test area with detectorized links sending data to the TIC, these restrictions were accepted.

The data-collection routes also required a convenient location where vehicles could turn around safely and avoid being off the study route for a long period of time. In addition, the routes needed a mix of link and intersection characteristics. The presence of detectors and the mix of link types are both necessary to the procedures used in the TTP algorithm. Alternative study routes were either too short or too long or did not have the desired mix of link types.

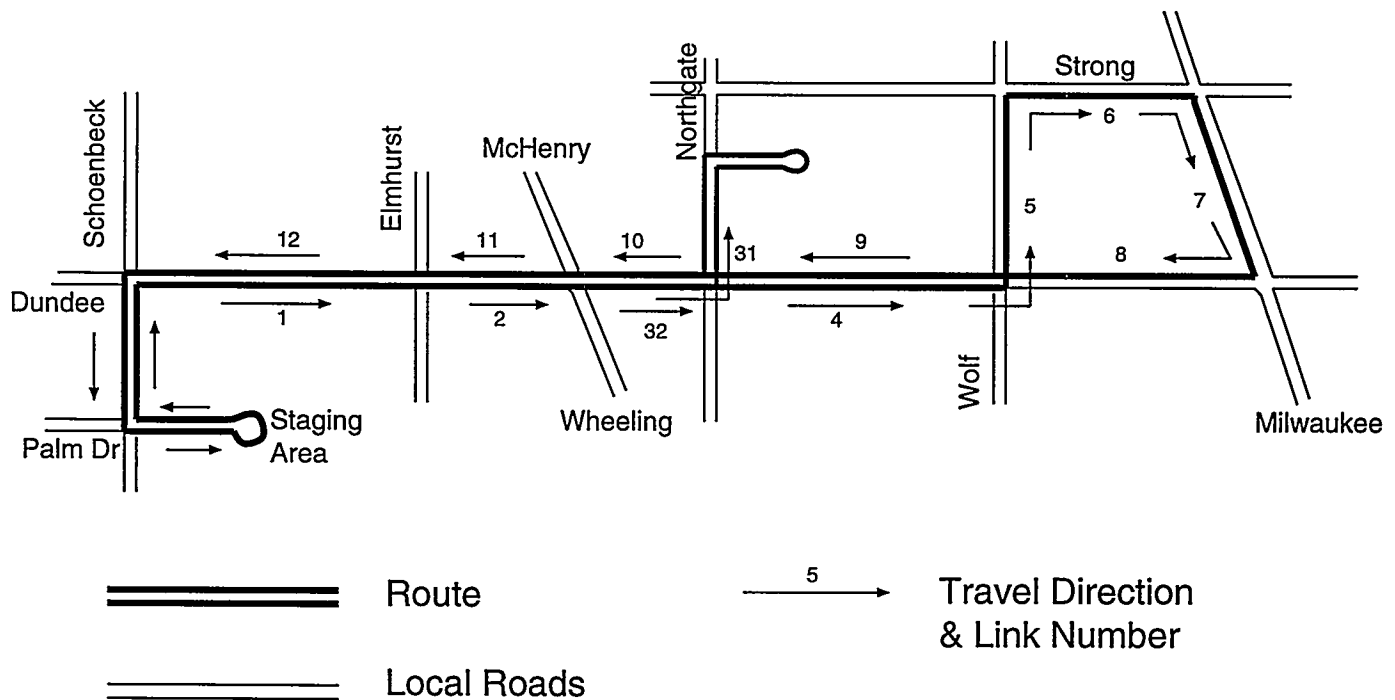

Figure 3: Probe-Data Collection: Dundee Road Routes

Probe data used in the TTP procedure were collected along the two routes depicted in Figure 3. The longer 12-link route, which extends to Milwaukee Avenue in the east, was designed to be completed within a fifteen-minute period. During the off-peak time period most drivers completed the route in ten to fourteen minutes. During the peak period this route proved to be too long to complete in fifteen minutes and a shorter alternative was used. This route includes the left turn on Link 31 onto Northgate where drivers were able to turn around and proceed to Link 10. Thus, with twelve cars on the road (on average) these routes would yield one link report per minute and five reports per five-minute interval.

The section of the route on Schoenbeck Road and Palm Drive (near the west end)

was used as a staging and turnaround area; since it was too short to complete a recognized link, data were not collected for this section of the route.

The first seven weeks of data collection (June 5—July 20) consisted of driving on these two set routes. After that period, data were additionally collected from other routes, within the same area, to allow an analysis of turning relationships. Table 1 shows the number of probe reports recorded for each day of data collection. The evaluation which is the subject of this report only concerns those data collected on the Dundee Road routes (see Figure 3), during the week beginning July 17. It may be seen from Table 1 that the week beginning July 17 provides the largest number of probe reports.

3.1.2 Data-Collection Schedule

At the beginning of each day of data collection, a twelve-noon briefing was held at the ADVANCE office in Schaumburg. At this time the drivers were assigned vehicles and they left the office at approximately 12:30 pm. Data were collected by probe vehicles driven in the study area between 1:00 pm and 7:00 pm, with breaks as described below.

On each day of data collection a field manager was present at the staging area. The field manager ensured that vehicles were driven on the study routes at satisfactory headways and instructed drivers when to take breaks.

The drivers were given a ten-minute break from approximately 2:00 pm to 2:10 pm and another one from approximately 6:00 pm to 6:10 pm. Each driver took his or her break at a slightly different time, as each was dispatched by the field manager to the break area as they arrived at the staging area. During breaks each probe vehicle was inactive for more than ten minutes as time was lost off-route and also while the vehicle and MNA warmed up. The longest break occurred from 3:30 pm to 4:00 pm. After this break, during the two-hour peak period from 4:00 pm to 6:00 pm, the drivers operated their vehicles without scheduled breaks.

3.1.3 Data Processing and Reduction

Data received from probe-vehicle MNA reports were reformatted to retain only the information needed for this evaluation and only that data from the links seen in Figure 3. Information manually collected by probe drivers concerning incidents was then added to the probe-report database. Finally, the data were comprehensively reformatted into a form chosen to facilitate analysis.

Table 1: Probe Reports for each day of Data Collection

| Date | No of Reports | Percent of Total |
|-------|---------------|------------------|
| 6/05 | 660 | 1.3 |
| 6/07 | 395 | 0.8 |
| 6/08 | 1140 | 2.3 |
| 6/12 | 1382 | 2.7 |
| 6/13 | 1712 | 3.4 |
| 6/14 | 1014 | 2.0 |
| 6/15 | 446 | 0.9 |
| 6/19 | 1178 | 2.3 |
| 6/20 | 1591 | 3.1 |
| 6/21 | 1503 | 3.0 |
| 6/22 | 2372 | 4.7 |
| 6/26 | 2037 | 4.0 |
| 6/27 | 1481 | 2.9 |
| 6/28 | 1744 | 3.4 |
| 6/29 | 1546 | 3.1 |
| 7/05 | 1560 | 3.1 |
| 7/06 | 1996 | 3.9 |
| 7/10 | 1689 | 3.3 |
| 7/11 | 1282 | 2.5 |
| 7/12 | 1507 | 3.0 |
| 7/13 | 1046 | 2.1 |
| 7/17 | 2285 | 4.5 |
| 7/18 | 2252 | 4.4 |
| 7/19 | 2140 | 4.2 |
| 7/20 | 1901 | 3.8 |
| 7/24 | 880 | 1.7 |
| 7/25 | 907 | 1.8 |
| 7/26 | 1017 | 2.0 |
| 7/27 | 899 | 1.8 |
| 7/31 | 949 | 1.9 |
| 8/01 | 1069 | 2.1 |
| 8/02 | 1038 | 2.1 |
| 8/03 | 1139 | 2.3 |
| 8/04 | 949 | 1.9 |
| 8/07 | 1058 | 2.1 |
| 8/08 | 1050 | 2.1 |
| 8/09 | 873 | 1.7 |
| 8/10 | 933 | 1.8 |
| Total | 50,620 | 100.0 |

3.2 Detector-Data Reports

TTP also makes use of detector data, which are gathered from in-road loop detectors located along the data-collection routes. For a comprehensive discussion of how these data are processed by the Detector Travel-Time Conversion (DTTC) algorithm, see Berka *et al.* (1996). The following subsection is intended to act as a brief introduction to the detector data used in TTP.

3.2.1 Data Collection

As seen in Figure 3, probe-data collection took place along Dundee Road in Wheeling, Illinois. While Dundee Road has about 30 intersection approaches which can generate on-line detector data for the ADVANCE project, the routes selected for data collection contain only three detectorized links (Links 1, 7 and 11 on Figure 3). Because the data-collection exercise was designed to concentrate probes on fewer links, thereby simulating a larger deployment over a larger study area, these three detectorized links provide sufficient data for our purposes.

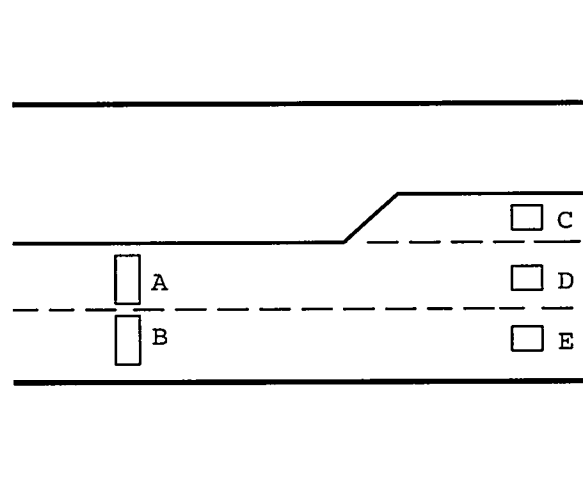

Figure 4: Location of Loop Detectors Used in Data Collection. (A through E represent in-ground detector locations.)

Two types of in-road loop detectors are present on intersection approaches on Dundee Road, which are part of two closed-loop systems. System detectors (detectors A and B in Figure 4) are located 250-300 feet upstream of the intersection and approach detectors (labeled C, D and E in Figure 4) are located just upstream of the stop line. While both types of detector measure traffic volume and occupancy, TTP only uses information from the system detectors, A and B. These two detector groups are used to actuate traffic signals, allowing for coordinated green times and continuous traffic flow along Dundee Road. Because of the presence of other arterials leading into Dundee Road, detector data also help coordinate traffic flows among these other roads.

Detectors are generally placed in parallel positions along a link, as seen in Figure 4.

Information is collected from system loop detectors for each closed-loop system (type Econolite KMC-10000 controllers), which begin data transmission back to the TIC. These data, along with information sent in by MNAs in the probe vehicles (transmitted to the TIC using radio frequency), constitute part of the TIC's communications subsystem. Detector data are sent at five-minute intervals. As recorded by the TIC, these data have a dual nature, and are stored in both statically and dynamically-generated formats. Data collected in this fashion are used on-line for ADVANCE project tasks such as TTP and are then archived.

3.2.2 Data Processing and Reduction

Detector data are sent in five-minute intervals to the TIC. These data are then processed on-line into usable configurations. Data for use in evaluations are then reprocessed off-line into configurations matching those of the MNA and memory-card data to allow for easy comparison. There are two basic forms for detector data: detector-by-detector and aggregated. Detector-by-detector data contain separate reports for each detector. Aggregated data are detector data aggregated over all detectors within a given group by averaging occupancy and summing the volume; this process creates a data set providing multiple reports for links at specific time stamps. DTTC, and thus TTP, uses aggregated data, which includes two values (average occupancy and total volume) derived from detectors at parallel locations on a given link.

The data are next organized into a database. As part of this process, the data are reduced to eliminate links not on the study route. Data reduced in this fashion produce a data set similar in format to Table 2, which is based on the output for August 1, 1995. Detector data are reduced to only include those links within the route shown in Figure 3, that is, Links 1, 7 and 11. For a full discussion of the Detector Travel-Time Conversion (DTTC) algorithm, see Berka *et al.* (1996).

Table 2: Sample of Reduced Data Output

| Date m/d/yr | Time hr/min/sec | Traffic Volume vehicles per 5-minute interval | Occupancy (% of time) | Link ID (hex) | Link ID | Detector Station Name |
|----------------|--------------------|---|--------------------------|---------------|---------|-----------------------------|
| 8 1 95 | 13 2 27 | 72 | 16 | "8cae7" | 11 | "DU-W_83" |
| 8 1 95 | 13 2 27 | 60 | 9 | "88c9a8" | 7 | "DU-S_MILWK" |
| 8 1 95 | 13 2 27 | 91 | 25 | "88cb2b" | 1 | "DU-E_83" |
| 8 1 95 | 13 2 27 | 64 | 25 | "88c9a8" | 7 | "DU-S_MILWK" |
| 8 1 95 | 13 2 27 | 83 | 19 | "88cb2b" | 1 | "DU-E_83" |
| 8 1 95 | 13 2 27 | 67 | 6 | "8cae7" | 11 | "DU-W_83" |

4 Travel-Time Prediction

4.1 Predicted and Actual Travel Times

Every five minutes the TIC computes travel-time predictions for subsequent five-minute intervals. These predictions are evaluated by comparing them to actual travel times collected by probe vehicles for the following four time periods (where time 't' is the end of the five-minute period providing input for the algorithm):

- Current estimate (from t to t+5 minutes),
- Five-minute forecast (from t+5 to t+10 minutes),
- Ten-minute forecast (from t+10 to t+15 minutes) and
- Fifteen-minute forecast (from t+15 to t+20 minutes).

The current estimate comes from probe or fused data and pertains to the period immediately after the end of the five-minute data accumulation period. The three forecasts are products of the travel-time prediction (TTP) algorithm (see Liu and Sen, 1995). In order to differentiate between the two we will use the term *estimate* for the current estimate and the term *forecast* for the TTP output. All four are estimates.

The comparison of the probe and TTP data is not straightforward for several reasons. First, the TIC broadcasts information to the probe vehicle (MNA) only when the TTP differs from the static profile estimate by more than twenty seconds. For this reason many of the TTPs are not broadcast; we will be evaluating all of the TTPs regardless whether or not they are transmitted to the probes. Second, the MNA and the TIC use slightly different five-minute intervals. The MNA uses multiples of five in defining time intervals while the TIC uses the time at which it is first powered up, as the beginning of the first five-minute interval and therefore it is not synchronized with the MNA. Even though the MNA places the data from the TIC into its own five-minute scheme we are evaluating the performance of the TIC TTPs based on the five-minute scheme recognized by the TIC. For example, if the TIC concludes its TTP computation at 1:04 pm then we will compare its first TTP against the actual probe data from the 1:04 - 1:09 pm period and the next one for the 1:09 - 1:14 pm period.

4.2 Prediction Algorithm

A decision was made early in the development of the TTP algorithm to establish an estimating procedure which is rather conservative (defined as preferring gradual development to abrupt change). This reflects the expectation that some travel times will vary substantially from the norm and these very isolated cases should not seriously affect the forecast. High travel times in a single five-minute period or even several five-minute periods may only signify a momentary problem which can disappear as

quickly as it occurred. There may also be cases of motorists voluntarily stopping on the shoulder, reporting high travel times and implying congested conditions when none exist. This general phenomenon is illustrated on Figure 5. The y -axis on each plot displays the travel times and the x -axis represents the seventy-two five-minute intervals from 1:00 pm to 7:00 pm. Each individual probe travel time is plotted with the symbol \star and the current estimates and five, ten and fifteen-minute forecasts with the symbol \circ . This convention is used throughout this paper.

Just after 5:00 pm (Interval 48) two probe vehicles reported travel times of between 500 and 600 seconds (nearly ten minutes) within the same five-minute interval. It is not important why this occurred but rather how the TTP algorithm reacted to it. These two high travel-time readings occurred just once and all the other reports before and after were within the same general range of less than one hundred seconds.

The current estimate for the five-minute period in which the high readings occurred jumped from about 60 seconds in the previous five-minute interval to 160 seconds. In the following estimate the value was down to 120 seconds and then subsequently to 80. In this case the estimate did not overreact to the two high probe reports. Had it done so it would have likely taken it a fair amount of time for the estimate to return to the more normal conditions experienced in the very next five-minute interval.

On all three forecasts the effect of these two high travel times is definitely muted. By the fifteen-minute forecast all travel-time forecasts for the time in question are less than one hundred seconds. In this special case the TTP functioned particularly well. A more complete evaluation follows in the next section.

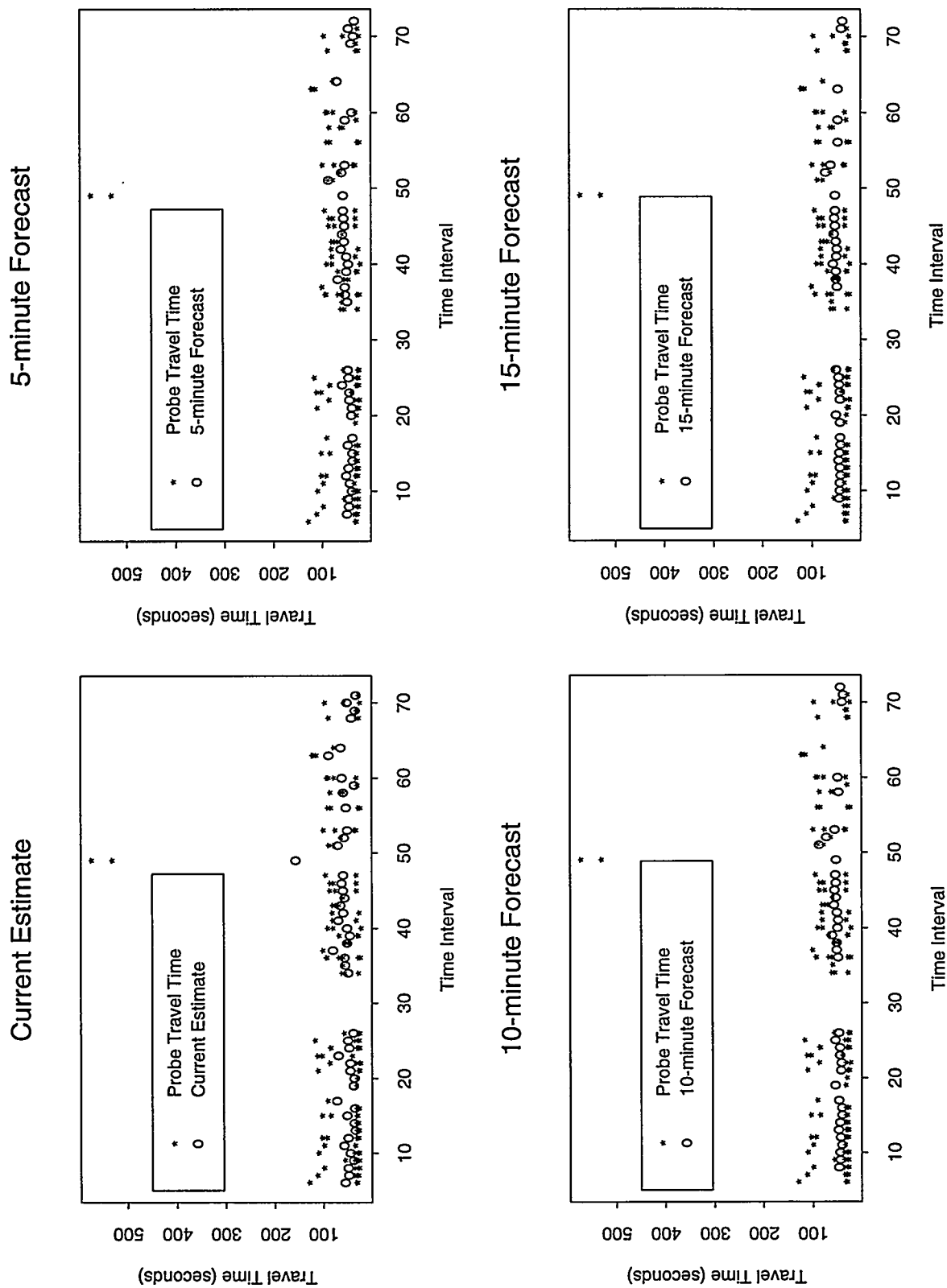

Figure 5: Individual Probe Travel Times and Probe-Only Estimates by Time Interval: Link 2, July 20

5 Results of TTP Evaluation

5.1 Selection of Links for Evaluation

Four links were selected for close examination from among the thirteen links driven. Two of these links have detectors and two do not and since two are very congested during the peak and the other two are less congested, there is one example in each of four categories (based on level of congestion and the presence of a volume/occupancy detector). Each of these cases is discussed separately. These four links can be characterized as:

- Link 2: no detector, less congested,
- Link 9: no detector, congested,
- Link 11: detector, less congested and
- Link 7: detector, congested.

5.2 Probe Data Only

The evaluation of data collected by probes will be performed initially for the two links without detectors, Links 2 and 9. Later a comparison will be made on the other two links between travel-time estimates generated by detector and probe data and actual travel times.

5.2.1 Link 2: Less Congested

The evaluation in this section will use data from July 17, when the largest number of probe reports was collected. The basic data examined are displayed on Figure 6 which graphs the actual probe travel times and the predicted travel times. Notice that the scale of the y -axis is very different from Figure 5 and that there are actually eleven reports over one hundred seconds on Figure 5 and only two on Figure 6. On Figure 6 we can clearly see the effects of signal timing on traffic flow and its effect on the TTP algorithm.

Probe-recorded travel times are clustered in two ranges. Travel times in the lower range, from 20 - 40 seconds, were recorded by vehicles that received a green signal at the end of Link 2 (the intersection with Wheeling/McHenry, see Figure 3); vehicles that received a red signal had to wait to complete Link 2 and therefore recorded higher travel times, of 60 or more seconds. This is most evident in the peak period, from 4:00 pm to 6:00 pm (Intervals 36 to 60).

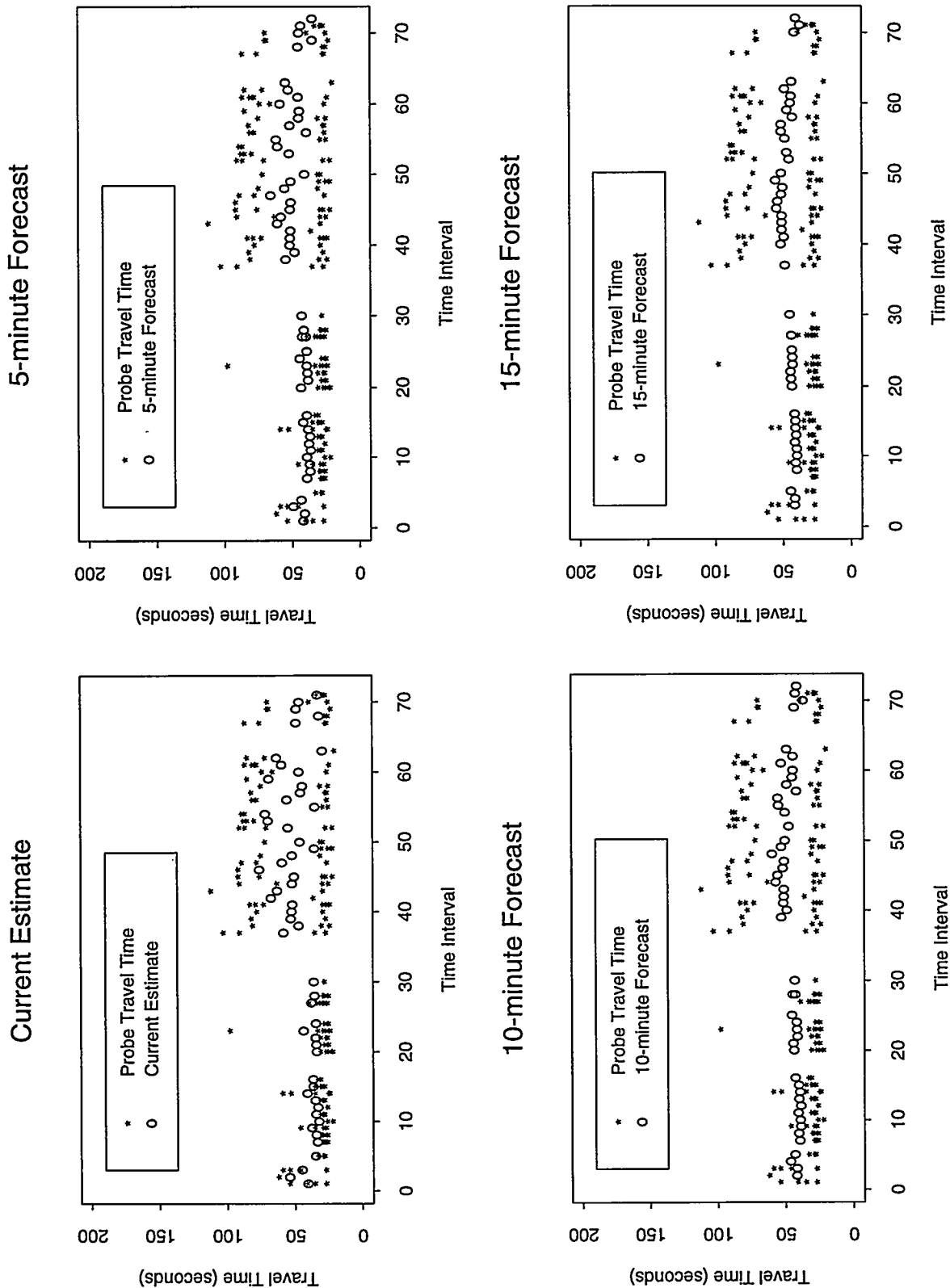

Figure 6: Individual Probe Travel Times and Probe-Only Estimates by Time Interval: Link 2, July 18

The upper left corner graph of Figure 6 shows the current estimates of travel time and the probe-reported travel times. During the first several hours the majority of the probes completed this link in less than forty seconds. The prediction is higher than the majority of the readings; this is attributable to the higher travel times by probes that were probably queued at a red light. During the latter part of the day, mainly in the peak period, the estimate is a compromise between the two sets of probes, those that did and those that did not have to stop for a red light.

For the subsequent three graphs on Figure 6 the probe-reported travel times remain the same but the forecasts change. Two trends can be seen in the behavior of the TTP algorithm. First, the dispersion in the forecast values decreases with each subsequent forecast. Second, the maximum values of the forecasts decline; the minimum increases also but more moderately. In this way, the range of forecast travel times is smaller.

For the five-minute forecast there are several values near 35 seconds but nearly all of the fifteen-minute forecasts are over 40 seconds. At the high end the forecasts drop from 65 seconds for the five-minute forecast to 55 seconds for the fifteen-minute forecast. Current estimates as high as 75 seconds demonstrate how the travel-time estimates decrease from the current estimate to the fifteen-minute forecast.

This data is presented in an alternative format in Figure 7. The probe travel time (y -axis) is plotted against against the current estimate and five, ten and fifteen-minute forecasts (x -axis). This figure also includes a line ($x = y$) marking equality between probe travel time and the estimate. It is evident from Figure 7 that most of the actual probe-reported travel times are either well above or well below the estimated travel times. This again shows the effect of signals on travel times on relatively short links.

Figure 6 displays each probe report but since the TTP is one estimate for each five-minute period, we also show the *mean* probe travel time graphed with the TTP forecasts (Figure 8). The two figures, for the individual and mean probe data, are rather similar. While Figure 8 is a more true one-to-one comparison (of a 5-minute estimate against a 5-minute mean) we will continue to emphasize the figures which show the probe reports individually. These figures show how well the individual probe reports match the TTP forecasts, and the problems associated with using one value (the mean) to represent actual travel times with high variances.

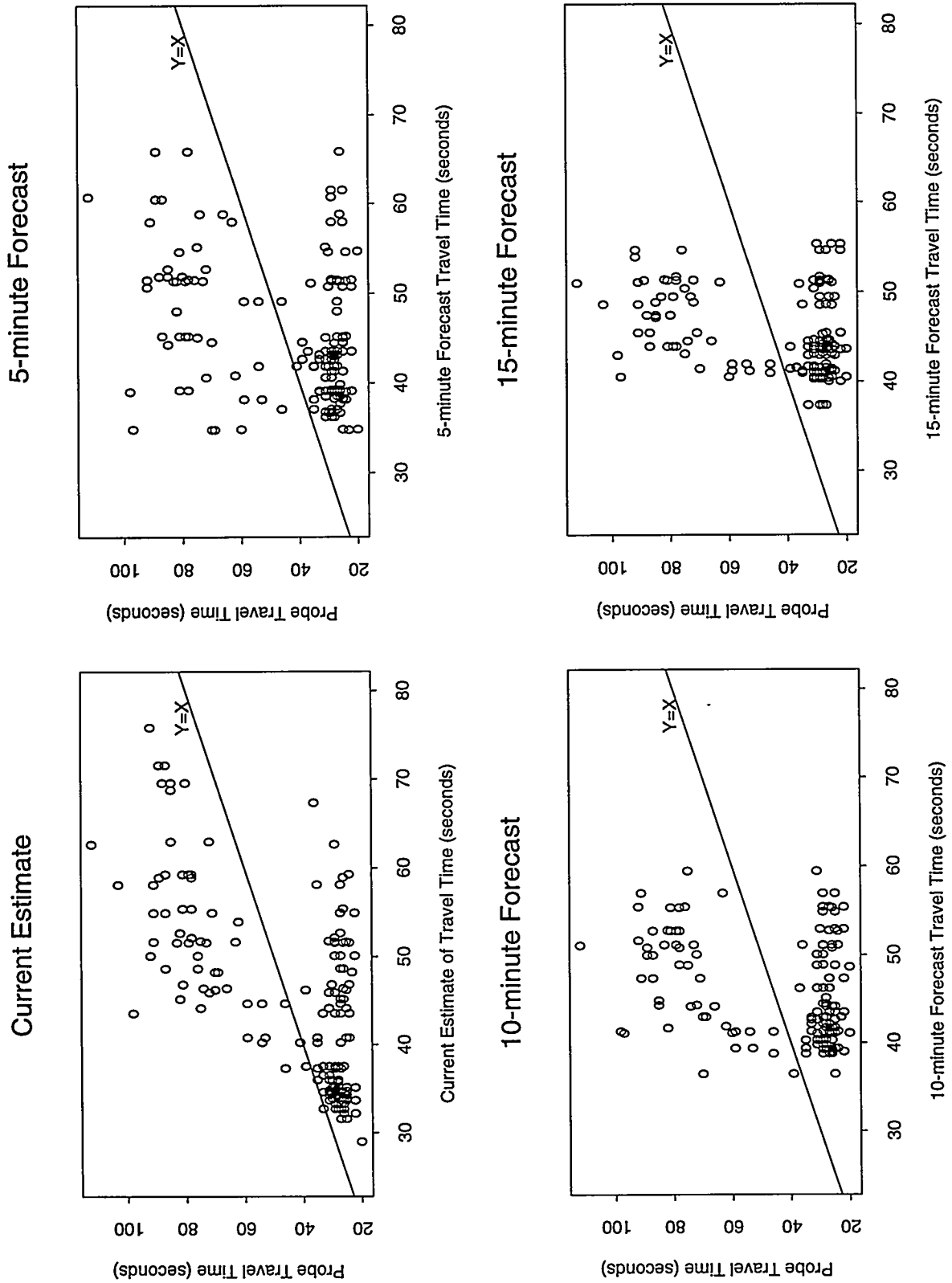
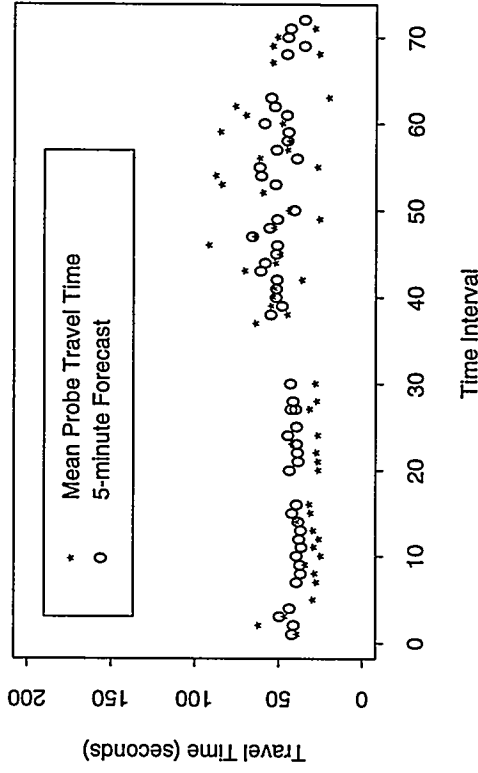
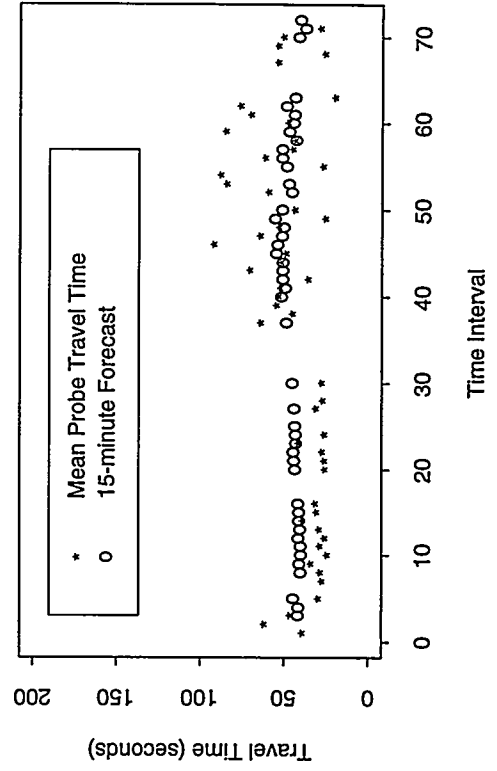

Figure 7: Probe Travel Times Plotted against Estimated and Forecast Travel Times: Link 2, July 17

5-minute Forecast



15-minute Forecast



Current Estimate

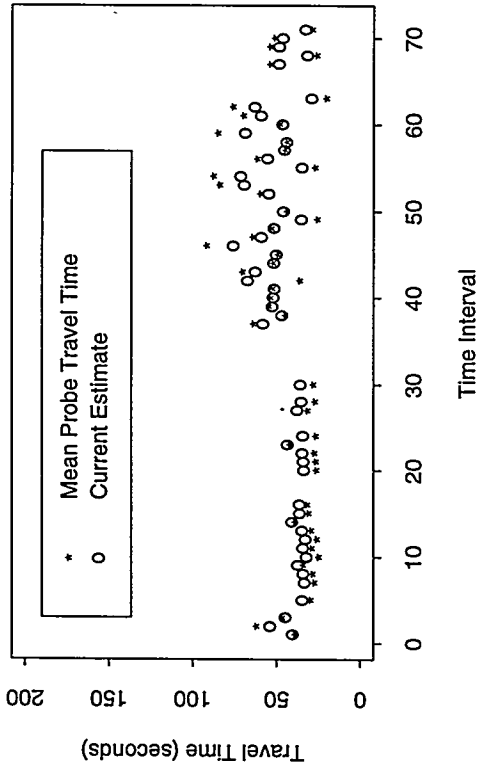

10-minute Forecast

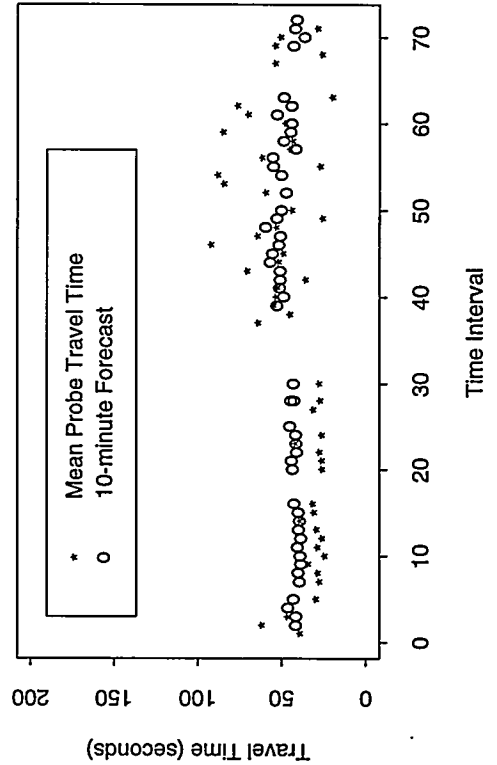

Figure 8: Five-Minute Mean Probe Travel Times and Probe-Only Estimates by Time Interval: Link 2, July 17

5.2.2 Link 9: Congested

Link 9 is a relatively long link (856 meters) which experiences a substantial increase in peak-period traffic. During the off-peak period the link is typically traversed in 50 - 100 seconds (Figure 9), but ten probe reports during the peak period were in excess of 300 seconds.

While the current travel-time estimates accurately reflect the probe reports, again the conservatism built into the algorithm is evident in the subsequent forecasts (five-minute to fifteen-minute forecasts). Even the current estimates do not reach the levels of the highest probe reports. At approximately 6:00 pm (Interval Number 60) there were four probe reports near the 500-second range but the estimates only reached 300 seconds.

During this same time-of-day interval the five-minute forecasts dropped to just over 200 seconds from 300 seconds for the current estimate. The forecasts continue to drop until they are all less than two hundred seconds for the fifteen-minute forecasts. In this latter case the TTPs illustrate a relatively symmetric pattern increasing to the peak (at approximately 5:00 pm, Interval Number 48) and declining thereafter. The patterns for the five-minute and ten-minute forecasts are much more irregular.

Again we examine the closeness of the match between probe and forecast travel times by graphing one against the other (Figure 10). In this case the y -axis extends to 500 seconds, compared with 120 seconds in Figure 7. Because of the many signal-cycle failures experienced in this link the distribution of probe travel times is not bimodal in character. The current estimates match the probe travel times reasonably well. Above 200 seconds, however, the probe times all exceed the estimates.

We show one more figure illustrating the comparison between the *mean* probe travel times and the travel-time forecasts for Link 9 (Figure 11). Even without this graph one can visualize the general relationship that the error in the estimate is small when the probe mean is small and it increases with the mean value. This is especially evident on the fifteen-minute graph.

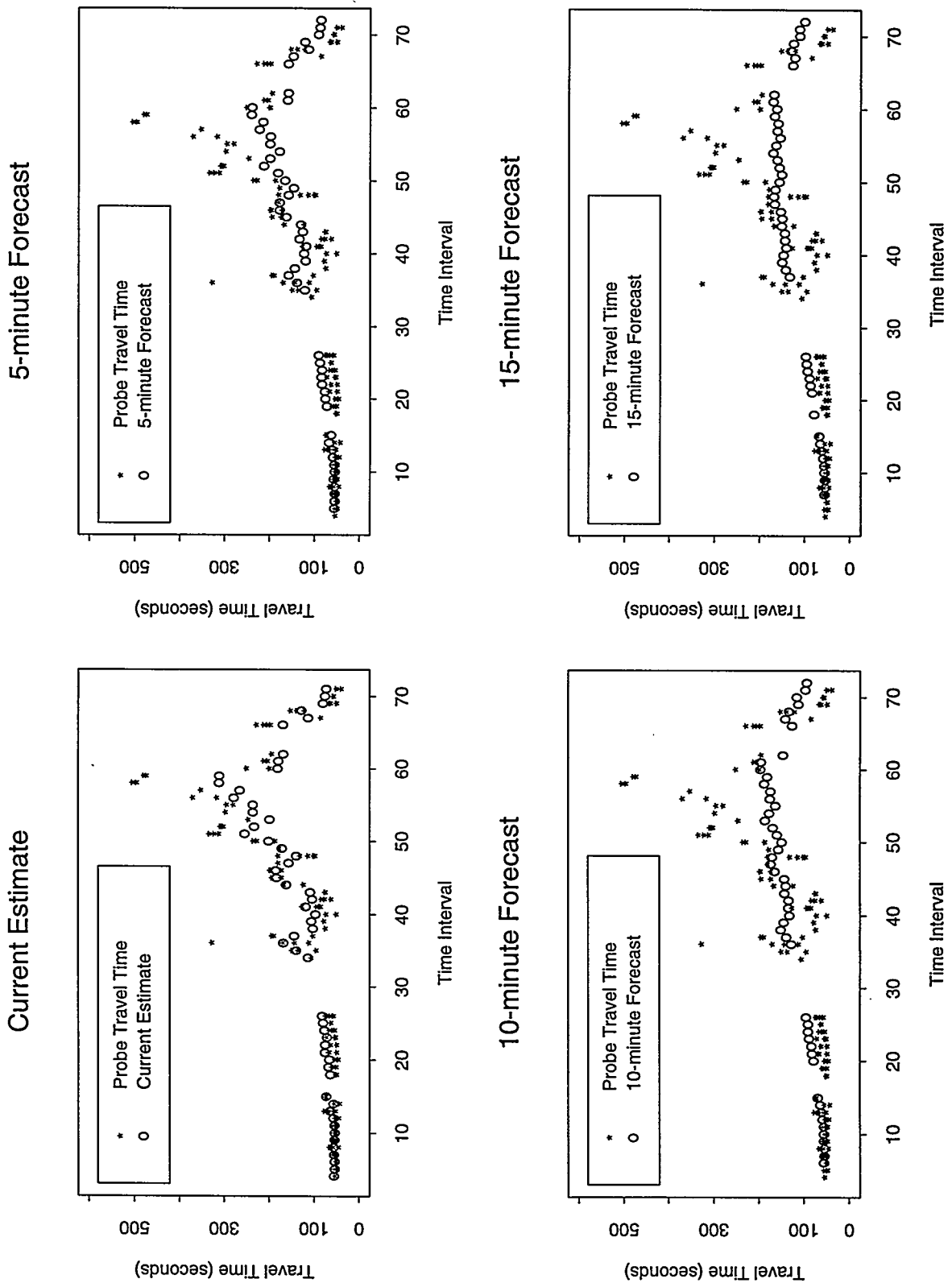

Figure 9: Individual Probe Travel Times and Probe-Only Estimates by Time Interval: Link 9, July 19

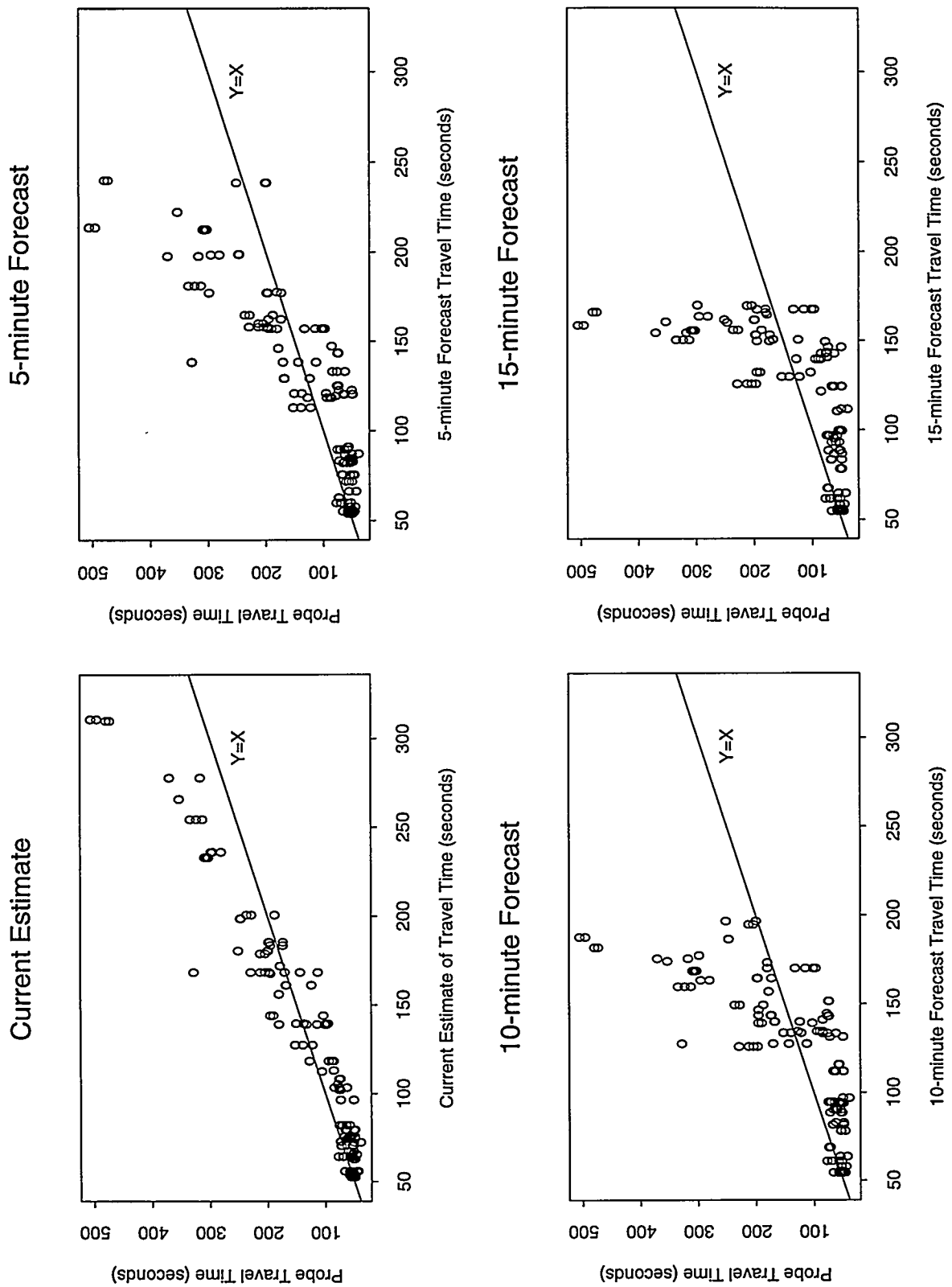

Figure 10: Probe Travel Times Plotted against Estimated and Forecast Travel Times: Link 9, July 19

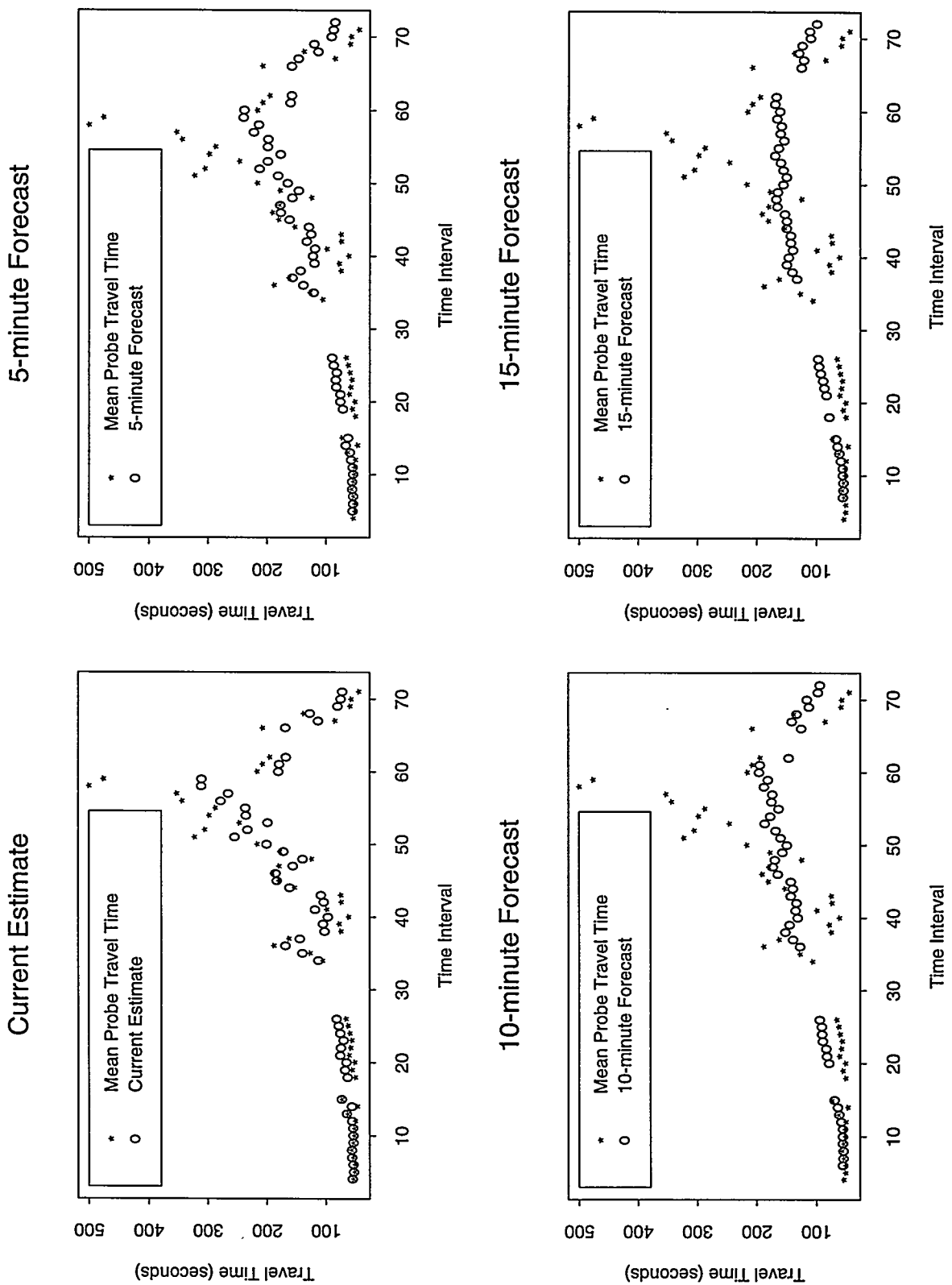

Figure 11: Five-Minute Mean Probe Travel Times and Probe-Only Estimates by Time Interval: Link 9, July 19

5.3 Detector Data Only

Volume and occupancy detectors are available on two of the study links, Links 7 and 11, which are discussed in this section. These detector-based estimates are compared with probe reported travel times and with estimates based on probe data only.

5.3.1 Link 11: Less Congested

Link 11 is a relatively short link (457 meters) on Dundee Road with a large discount retailer and an automobile dealer on the north side and a series of small stores on the south side. It is downstream from Link 9 which experiences substantial congestion but there are several reasons why Link 11 has relatively little congestion. First, much of the Link 9 congestion has turned off Dundee Road onto McHenry and Wheeling Roads. Second, there is a separate turning lane at the end of Link 11 relieving some of the traffic buildup. Third, the link is shorter than the queue on Link 9 during the maximum peak and therefore cannot have the excessive delays found on Link 9.

Figure 12 displays the travel times of probes on Link 11 (*), the detector-only estimates marked with a + sign and the estimates based only on probe data marked by the symbol o. For the current estimate as well as the three subsequent forecasts the detector-based estimates represent a reasonable approximation of the actual probe activity. On the plot of fifteen-minute forecast travel times it appears that the forecast travel times (40 to 60 seconds) are a good compromise between the travel times of those probe vehicles that had to stop at a red light (over 60 seconds) and those that did not (travel times of less than 40 seconds). Also there is little difference between the detector-only and the probe-only forecasts. The greatest differences occur for the current estimate but for each subsequent forecast the differences diminish.

5.3.2 Link 7: Congested

Link 7 is a southbound link with a right turn at the end of the link. At all times there is more traffic here than on Link 11, the other detectorized link. During the peak period there are major delays at this intersection in nearly all directions. As a consequence the detectors become saturated during most of the data-collection period and they provided relatively little useful information.

For the current estimates, the detector estimates (Figure 13) are around 60 seconds during the time intervals before the beginning of the peak period while most of the probes completed the link in over 100 seconds at this time. During the peak period the detector estimates are less useful. For a fuller discussion of this, see Berka *et al.* (1996).

The probe estimates and forecasts perform considerably better but due to their conservative nature they understate congested traffic conditions. This suggests the need for an adjustment in the algorithm, an important lesson learned in this evaluation process.

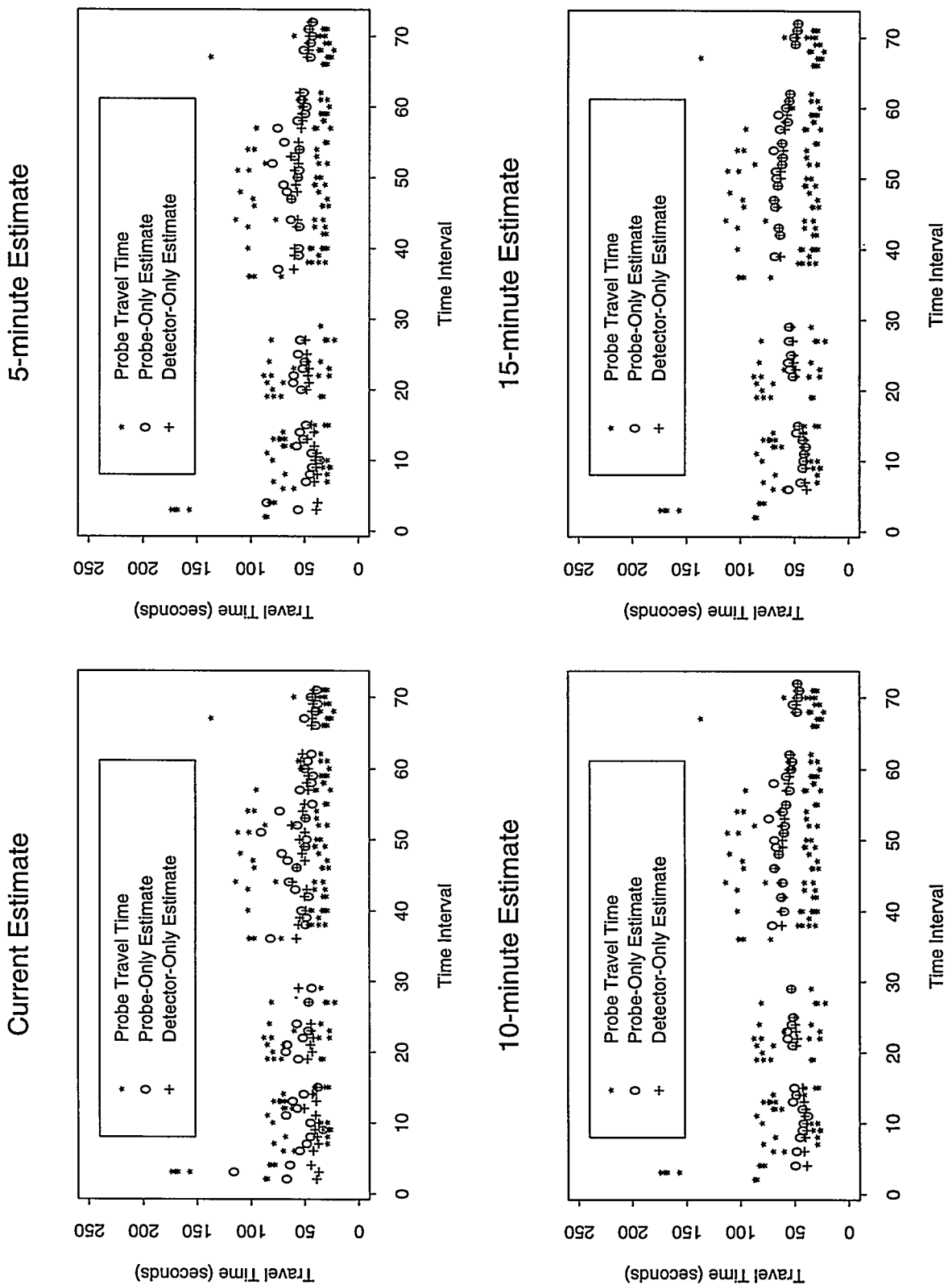
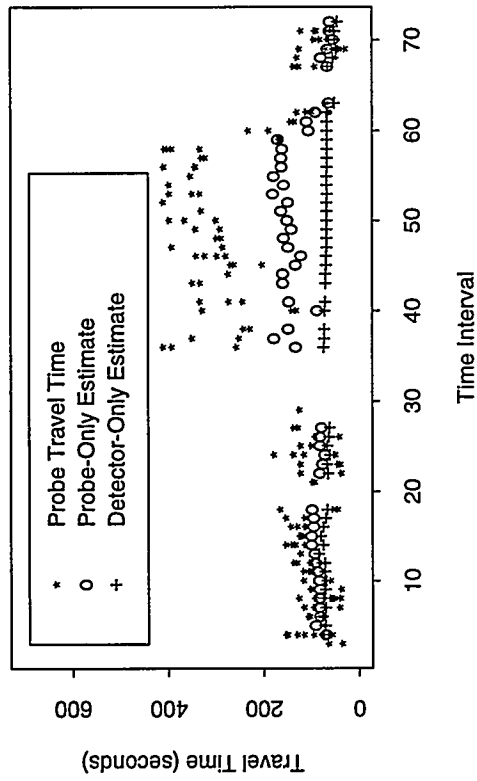
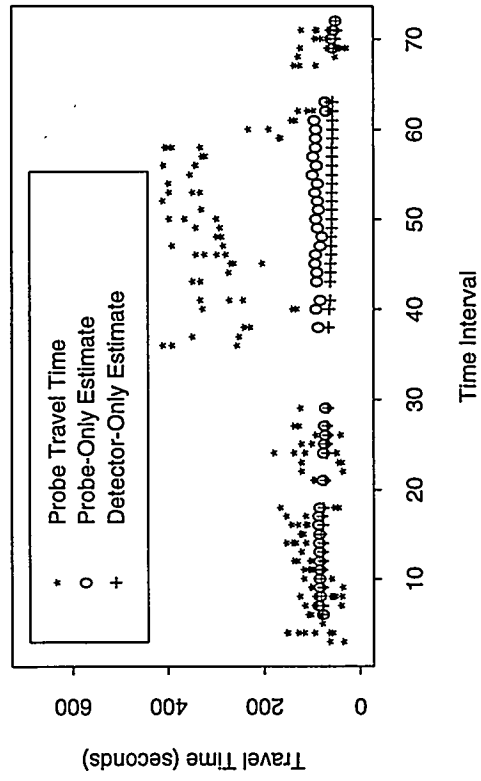

Figure 12: Individual Probe Travel Times and Detector-Only and Probe-Only Estimates: Link 11, July 17

5-minute Estimate



15-minute Estimate



Current Estimate

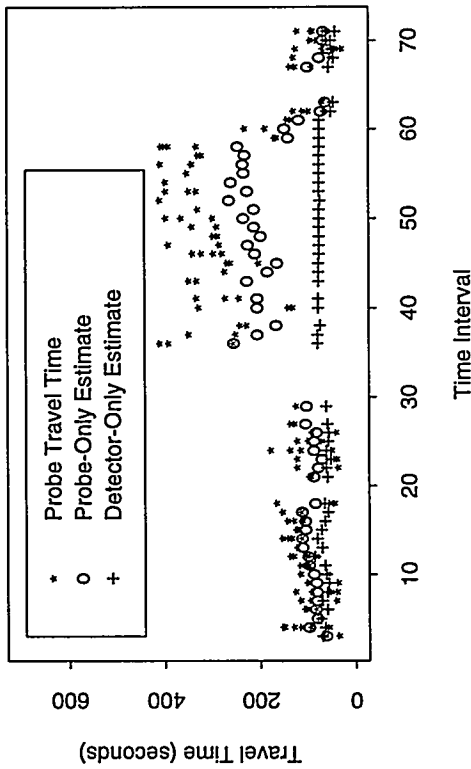

10-minute Estimate

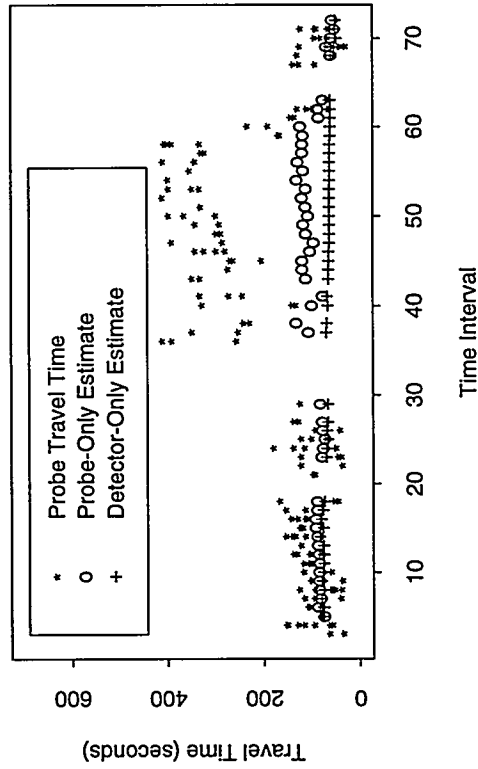

Figure 13: Individual Probe Travel Times and Detector-Only and Probe-Only Estimates: Link 7, July 18

5.4 Fused Probe and Detector Data

In this section we use fused data by combining reports from both probes and detectors. As a consequence several of the figures will resemble those seen previously. Again the analysis uses Links 7 and 11, the detectorized links.

5.4.1 Link 11: Less Congested

In the previous section it was evident that Link 11 had relatively little congestion and that both detector data and probe data yielded good estimates of travel time. Figure 14 shows actual probe travel times and the estimates based on fused data. As anticipated this figure is very similar to Figure 12, which shows the detector and probe estimates separately.

5.4.2 Link 7: Congested

Since the probe-only and the detector-only estimates varied substantially on Link 7, it is particularly interesting. Figure 15 displays the estimates based on fused data which look very much like a compromise between the probe-only and detector-only estimates (Figure 13). In the current estimates this compromise pulls the already conservative probe-only estimates downward and they are therefore even less representative of the actual travel times experienced. It is clear that from comparing Figures 13 and 15 that probe-only estimates are in this case superior to the fused-data estimates.

With the probe and detector data inputs used in this study to estimate TTPs, it is apparent that on congested links only probe data should be used and not fused (probe and detector) data. This fusion should only be performed during uncongested periods, but these periods are of minimal interest. They do not result in active transmission to the MNA; during uncongested periods the static profiles are adequate.

5-minute Forecast

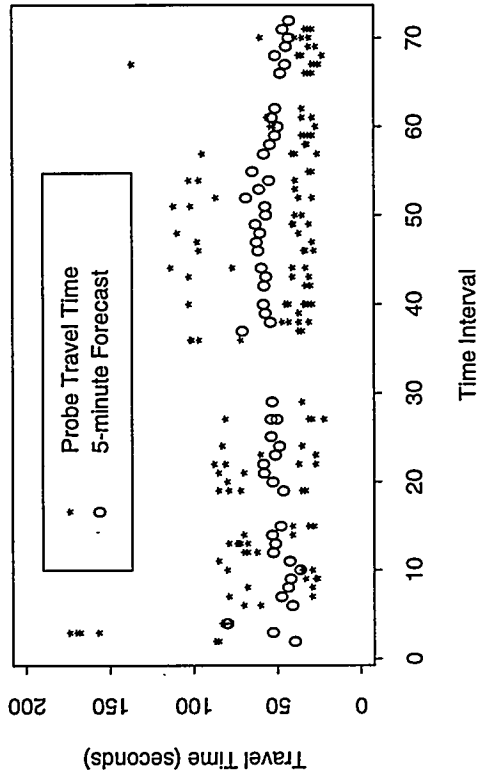

15-minute Forecast

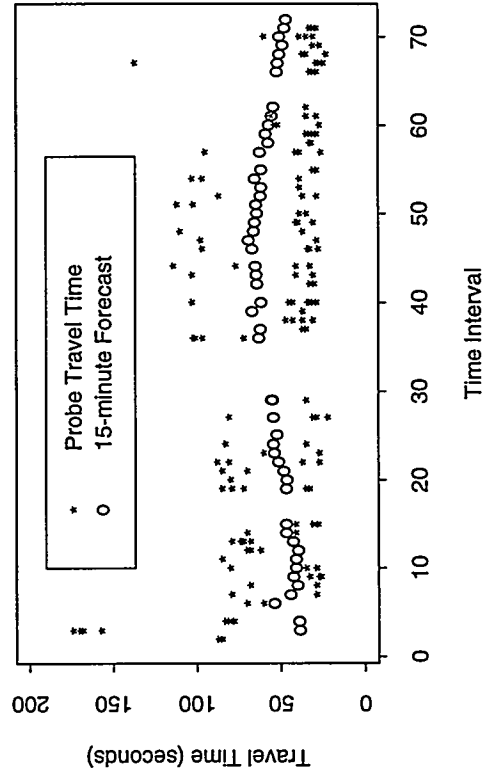

Current Estimate

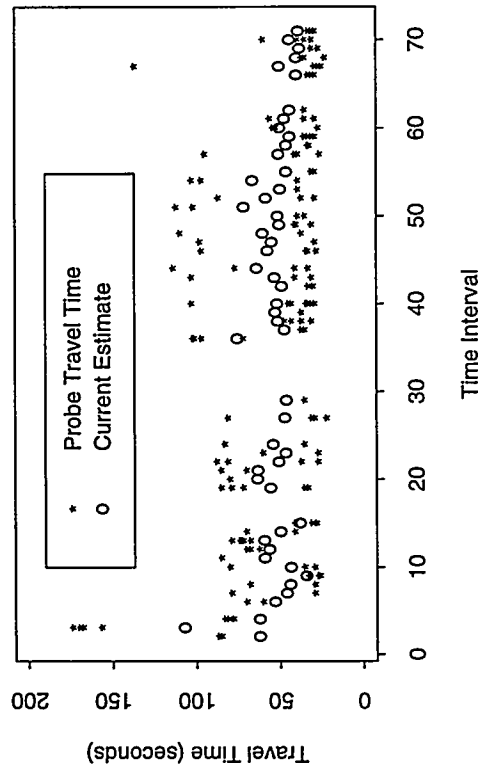

10-minute Forecast

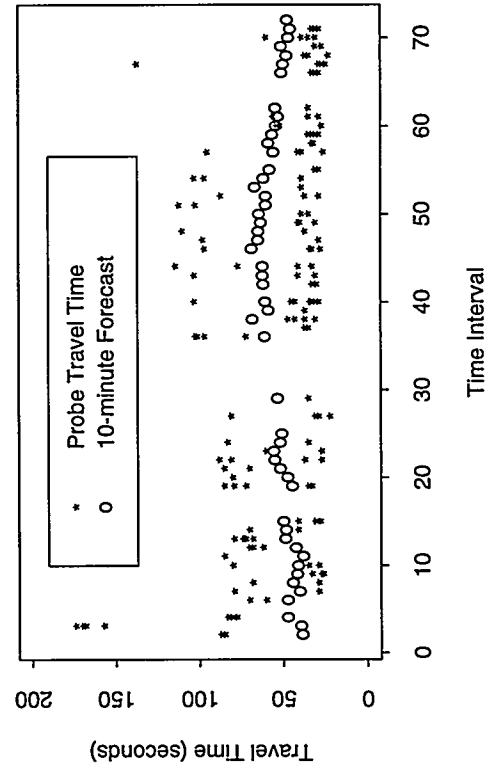

Figure 14: Individual Probe Travel Times and Estimates based on Fused Probe and Detector Data: Link 11, July 17

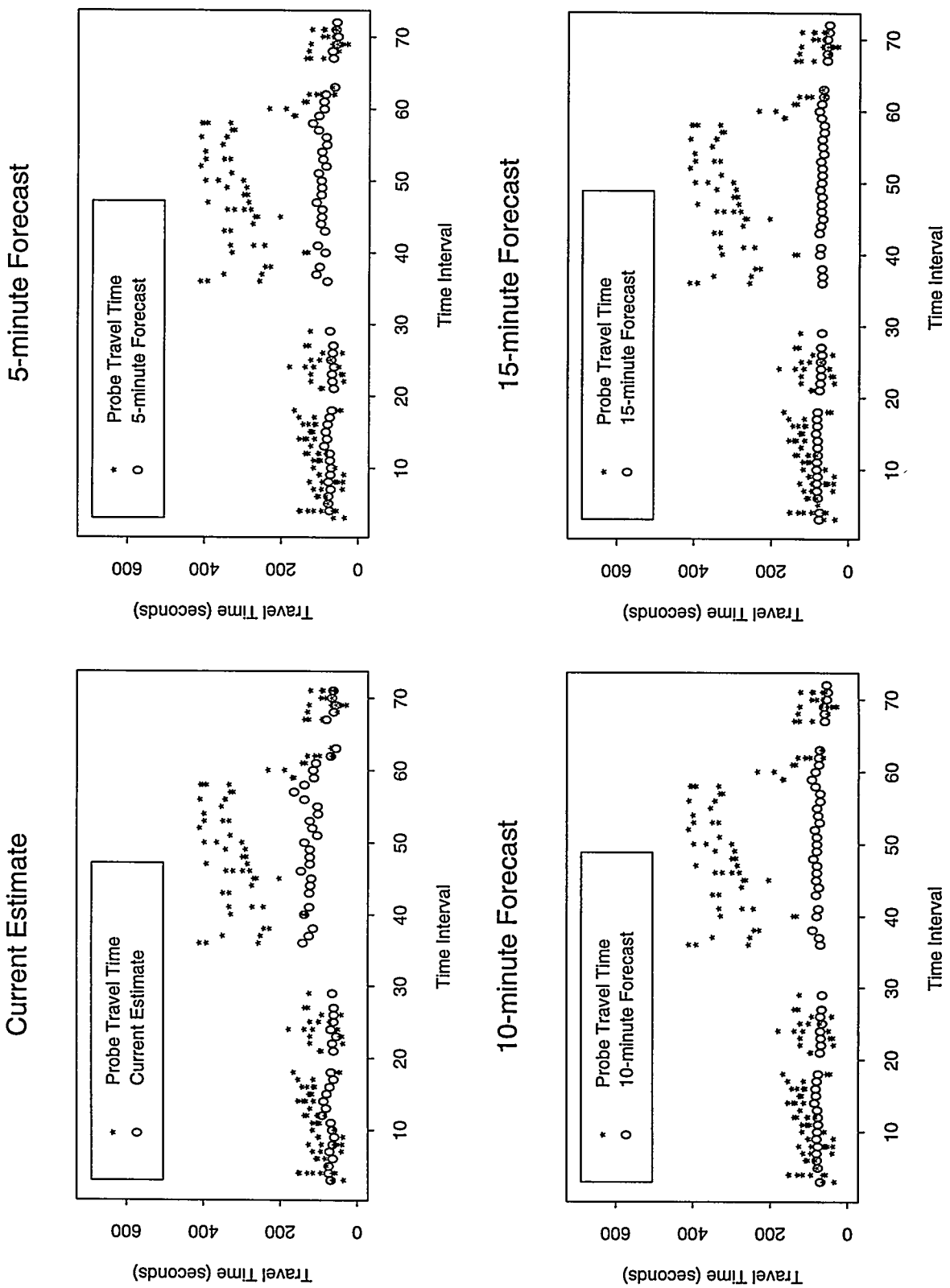

Figure 15: Individual Probe Travel Times and Estimates based on Fused Probe and Detector Data: Link 7, July 18

5.5 Probe Data Only at Varying Deployment Levels

In this section we will consider the current estimates and the five, ten and fifteen-minute forecasts of travel time with varying amounts of probe data input to the TTP algorithm. It is evident that a useful evaluation will consist of using only probe data in this section and not fusing these data with detector data. We originally intended to fuse probe data with detector data but in light of the findings in previous sections this seems unwise.

Starting with the current estimate only five-minute intervals with *at least four* probe reports are considered. We initially considered up to five probe reports per five-minute period but there were so few such periods that we substantially increased the sample by decreasing the number of probe reports to four. Those five-minute intervals with more than four reports have the excess probe reports eliminated in a random process. The estimate is made using the remaining four probe reports. In the next step one of the four probe reports is randomly deleted and all other five-minute intervals with exactly three probe reports are added. In this manner each subsequent step has a greater number of five-minute intervals with which to make a comparison between estimated and actual travel times.

We selected Link 7 for this analysis. It has the greatest congestion of any of the study links and even during the off-peak period is characterized by heavy traffic. The congested periods are far more interesting; during free-flow conditions we have already seen that both detectors and probes perform very well. Moreover, during these low-congestion periods very few updates would be sent to the MNA.

5.5.1 Current Travel-Time Estimates

We observed earlier that the current estimate was generally the most accurate of the four estimates (one “estimate” and three “forecasts”). We therefore start with these current estimates and examine them with initially one probe report per five-minute interval, then with two probes, then three and finally four probes per five-minute interval.

Figure 16 illustrates the current estimates using one to four probe reports and the actual probe travel times for the 72 five-minute intervals from 1:00 pm to 7:00 pm on July 18, 1995. It is obvious that the estimates, the \circ symbol, decrease in number as the number of probe reports per five-minute interval increases. While there are 59 five-minute intervals with at least one probe report there are only 51 with two probe reports, 29 with three and 17 with four (there are also 9 with at least five probe reports but this is too sparse to be included in this analysis).

Since we operated with a fixed number of vehicles throughout the day the frequency of multiple probe reports decreases as the study route travel time increases. This is logical but it results in very few five-minute intervals with at least four probe reports during the peak period. There are 24 five-minute periods during the 4:00 to 6:00 pm

peak period but only 9 with three reports and only 3 with four probe reports. By contrast there were 9 five-minute intervals during the two-hour period from 1:00 pm to 3:00 pm with four probe reports. As a consequence the amount of available data decreases as the problem becomes interesting.

During the first part of the day the estimates hover around one hundred seconds and do not deviate by more than +/- fifty seconds. The one-probe estimate dips down to approximately 50 seconds but the minimums are higher for the subsequent forecasts. Before the peak period there are several one-probe estimates near fifty seconds, only one for the two-probe estimate and the lowest three-probe estimate is even over sixty seconds. The high values before the peak period decline as the number of probes in the estimate increases but not as noticeably.

During the peak period the one-probe estimates range from under 150 seconds to just over 250 seconds. This is generally true for the two-probe estimate but the low values for the three-probe estimates drop out; all estimates are in excess of 200 seconds.

5.5.2 Five-Minute Forecasts

The same general pattern continues for the five-minute forecast. The forecasts for the early part of the day (Figure 17) fall into a slightly smaller range than exhibited for the current estimate. The most substantial changes are during the peak period when the forecasts drop by at least 50 seconds. Comparing the peak periods for the current estimate and the five-minute forecast (Figures 16 and 17) the estimates drop from approximately 250 seconds to 200 seconds.

Within Figure 17 there is relatively little difference. From time interval zero (1:00 pm) to interval number 60 (6:00 pm) the forecasts tend to move upward from approximately sixty seconds to 150 seconds. The major difference is that the number of estimates decreases as the number of probe reports increases from one to four.

5.5.3 Ten-Minute Forecasts

Figure 18 shows that the dispersion in the forecasts has declined (the vertical and horizontal axes are identical for Figures 16 through 19).

Visual inspection shows relatively little difference in the estimates from one probe to four probes per five-minute data-input interval. A subsequent section will examine actual values.

5.5.4 Fifteen-Minute Forecasts

For the last forecast we see the same pattern we have witnessed throughout this report, the forecasts become increasingly more conservative into the future. This is evident regardless how many probes are used (Figure 19). Because the dispersion in the estimates has declined, in this last set of estimates the change from one to four probes is very slight.

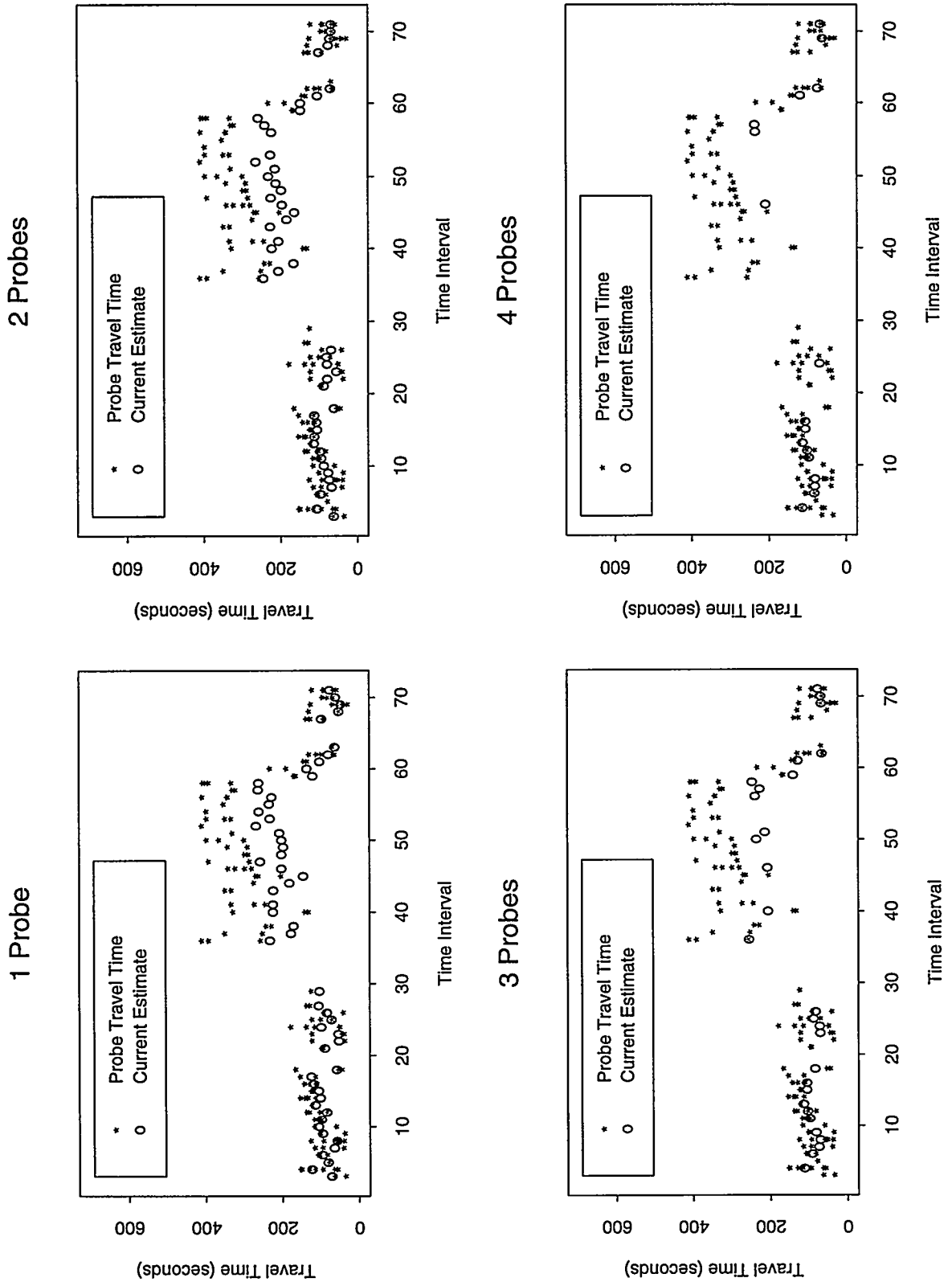

Figure 16: Individual Probe Travel Times and Current Estimates with Varying Numbers of Probe Reports: Link 7, July 18

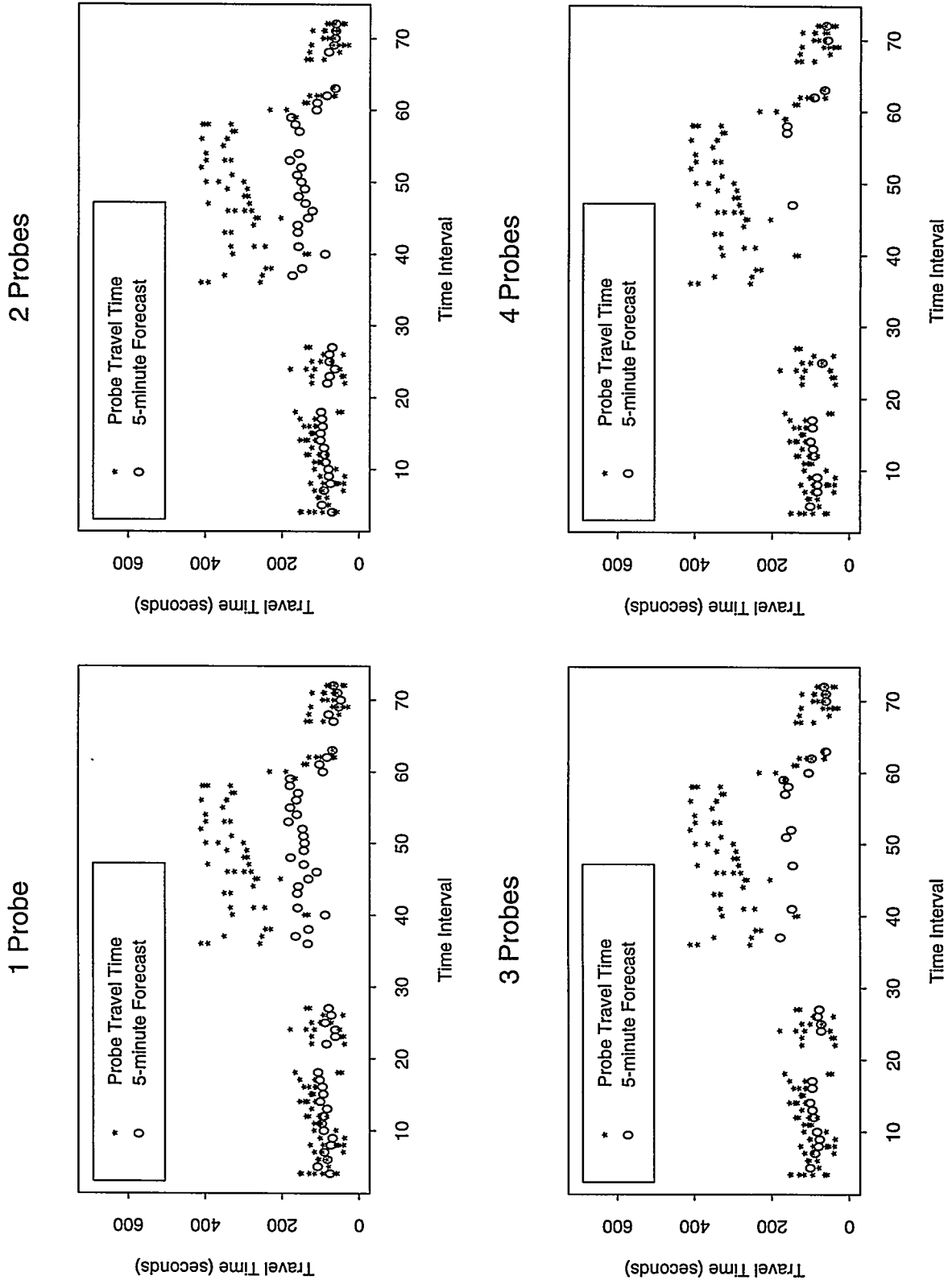

Figure 17: Individual Probe Travel Times and Five-Minute Forecasts with Varying Numbers of Probe Reports: Link 7, July 18

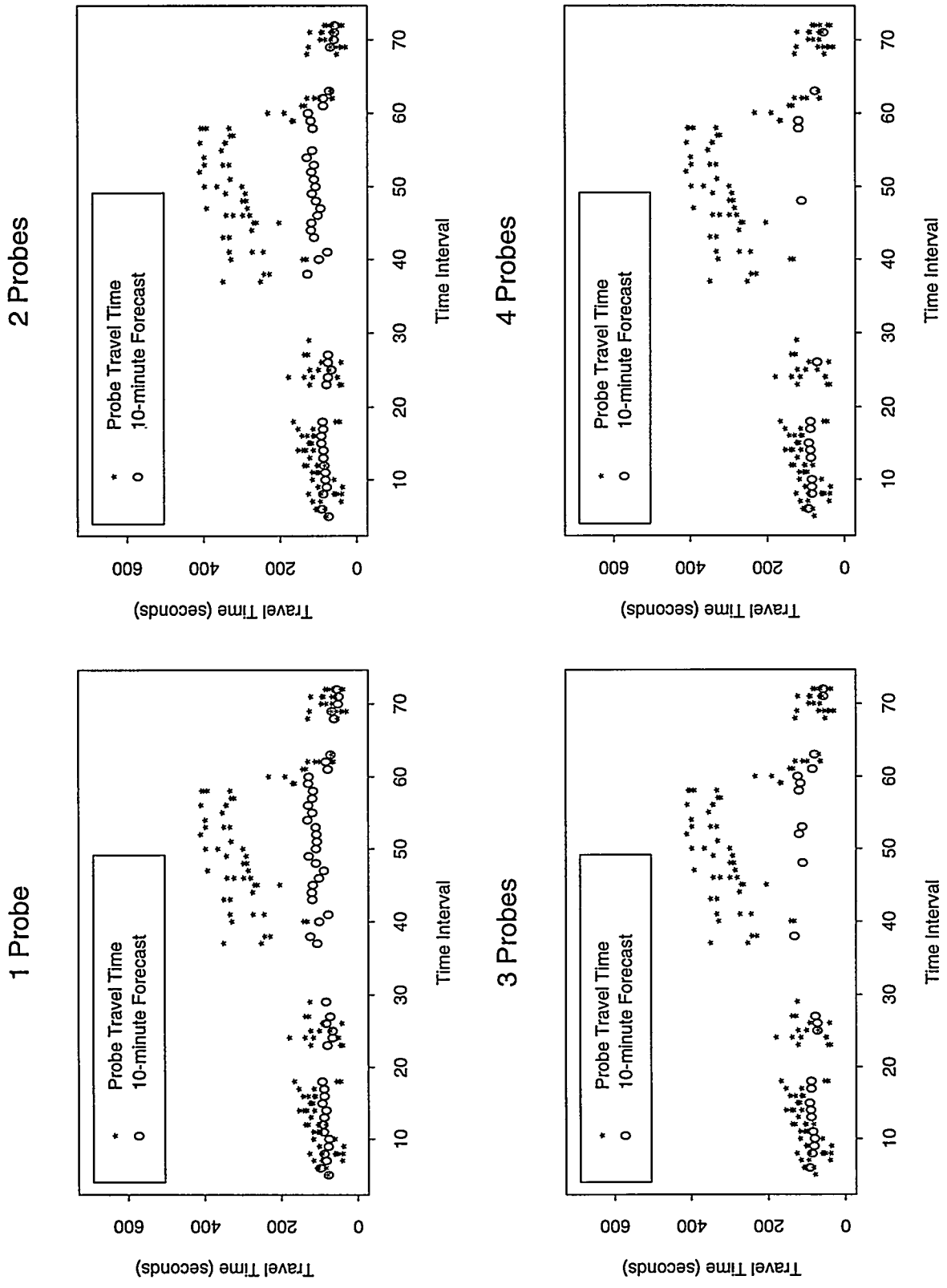

Figure 18: Individual Probe Travel Times and Ten-Minute Forecasts with Varying Numbers of Probe Reports: Link 7, July 18

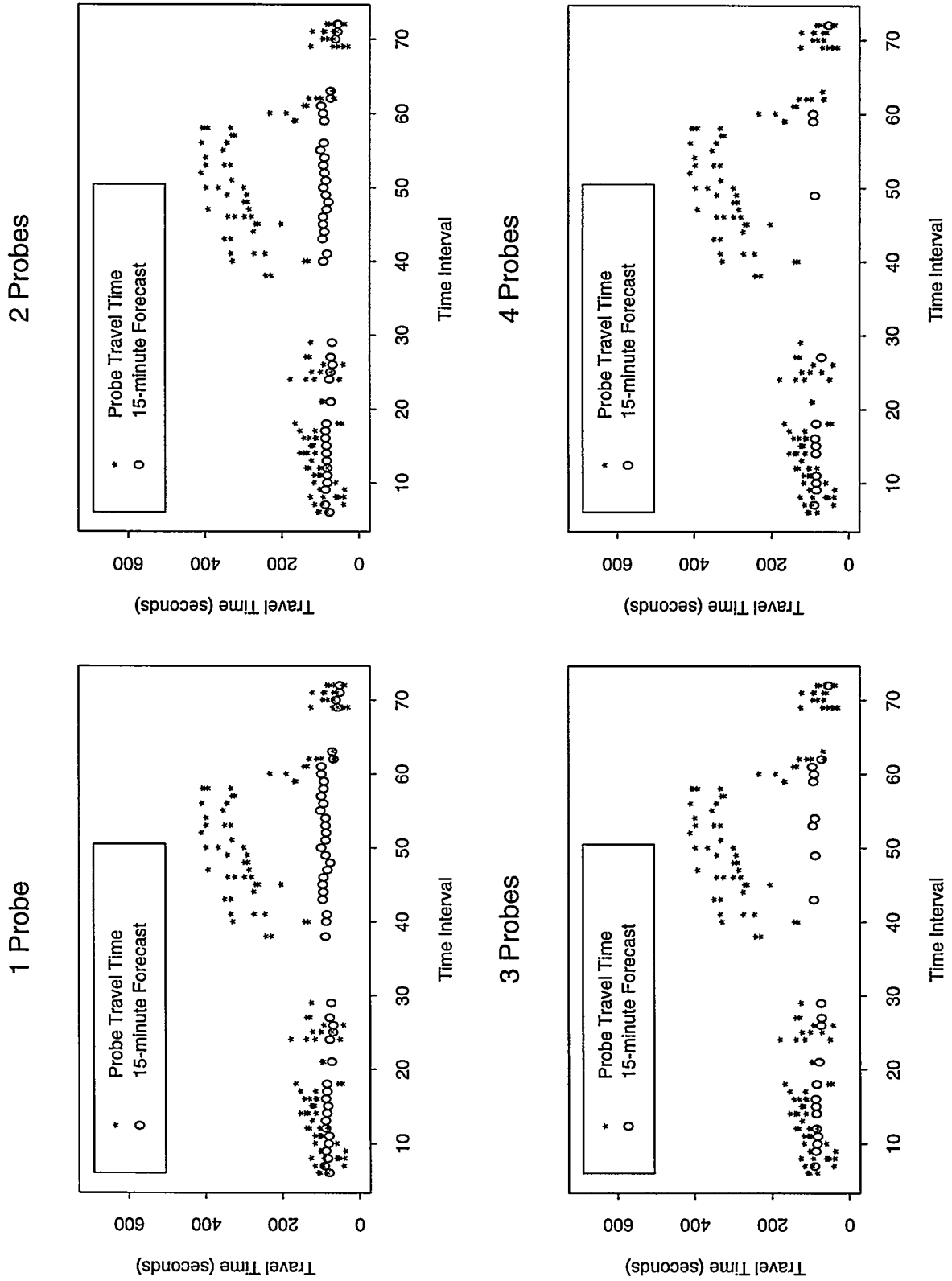

Figure 19: Individual Probe Travel Times and Fifteen-Minute Forecasts with Varying Numbers of Probe Reports: Link 7, July 18

5.5.5 Overview of Varying Number of Probe Reports

Another way to evaluate the performance of the TTP algorithm is to examine a table (Table 3) of the seventeen five-minute periods between 1:00 pm and 7:00 pm on July 18 with at least four probe-reported travel times on Link 7. This table reconfirms the earlier finding that the TTP algorithm is rather conservative and that the greatest change in travel-time estimates is for the current period as probe reports are added. By focusing on this column it is clear that in only a few cases there is a substantial change in the estimate after three probe reports have been included.

The first five-minute period (at 1:23:09 pm) started with a current estimate of 123 seconds which dropped to 106 seconds after the second probe report. The third probe report brought it up to 112 seconds and it did not change more than two seconds with the fourth and fifth probe reports. The greatest changes in the current estimate from three to four probes occurred at 1:33:01, 1:43:02, 5:48:25 and 6:08:14 but in all four cases the change was just under 10 seconds. For most of the other 5-minute periods the changes in estimates were only a few seconds.

The same pattern of small changes is more evident for the three forecasts. There are only minor changes after three probe reports have been included. Even during the peak period, when the driving times are high there is little change after the third probe report. All of the estimates between 4:00 pm and 6:00 pm are over three and a half minutes but the largest change in the forecasts is less than ten seconds. There are some periods where the estimates remain largely unchanged. This is true for the 2:08:01 pm and 2:18:00 pm periods.

The 15-minute estimates are the most conservative and therefore need the fewest probe reports. After three probe reports there are very few examples in which the changes are in excess of two seconds with the inclusion of an additional probe report, either from three to four or from four to five probe reports. If the algorithm were changed then it would likely be more sensitive to the number of probe reports but the present version seems to need no more than three probe reports.

Note that in reading across the table (from current estimate to 5, 10 and 15-minute forecasts), the forecast travel times decrease in all five-minute periods except for those beginning at 1:33:01 pm, 1:38:00 pm and 1:43:02 pm. During these time periods probe vehicles reported low travel times and the forecasts were higher to reflect more typical conditions.

Table 3: Travel-Time Estimates for 5-minute Periods with 4 or more Probe Reports:
Link 7, July 18

| Time | Current | 5-min | 10-min | 15-min | # Probes |
|----------|---------|--------|--------|--------|----------|
| 1: 23:09 | 123.43 | 106.62 | 96.88 | 91.37 | 1 |
| 1: 23:09 | 106.03 | 96.18 | 90.61 | 87.61 | 2 |
| 1: 23:09 | 112.03 | 99.78 | 92.77 | 88.91 | 3 |
| 1: 23:09 | 114.43 | 101.22 | 93.64 | 89.43 | 4 |
| 1: 23:09 | 113.23 | 100.50 | 93.20 | 89.17 | 5 |
| 1: 33:01 | 94.71 | 90.07 | 87.63 | 86.50 | 1 |
| 1: 33:01 | 95.91 | 90.79 | 88.06 | 86.76 | 2 |
| 1: 33:01 | 91.11 | 87.91 | 86.33 | 85.73 | 3 |
| 1: 33:01 | 82.86 | 82.96 | 83.36 | 83.94 | 4 |
| 1: 38:00 | 64.45 | 72.25 | 77.28 | 80.63 | 1 |
| 1: 38:00 | 66.85 | 73.69 | 78.14 | 81.15 | 2 |
| 1: 38:00 | 74.65 | 78.37 | 80.95 | 82.84 | 3 |
| 1: 38:00 | 81.55 | 82.51 | 83.43 | 84.33 | 4 |
| 1: 43:02 | 56.99 | 68.12 | 75.14 | 79.02 | 1 |
| 1: 43:02 | 73.19 | 77.84 | 80.97 | 82.52 | 2 |
| 1: 43:02 | 70.79 | 76.40 | 80.10 | 82.00 | 3 |
| 1: 43:02 | 80.69 | 82.34 | 83.67 | 84.14 | 4 |
| 1: 58:07 | 96.94 | 91.19 | 87.42 | 84.83 | 1 |
| 1: 58:07 | 94.54 | 89.75 | 86.56 | 84.31 | 2 |
| 1: 58:07 | 97.54 | 91.55 | 87.64 | 84.96 | 3 |
| 1: 58:07 | 97.09 | 91.28 | 87.48 | 84.86 | 4 |
| 2: 03:05 | 82.83 | 82.40 | 81.82 | 81.16 | 1 |
| 2: 03:05 | 97.23 | 91.04 | 87.00 | 84.27 | 2 |
| 2: 03:05 | 103.23 | 94.64 | 89.16 | 85.56 | 3 |
| 2: 03:05 | 100.83 | 93.20 | 88.30 | 85.04 | 4 |
| 2: 03:05 | 99.87 | 92.63 | 87.96 | 84.84 | 5 |
| 2: 08:01 | 113.11 | 100.24 | 92.21 | 87.06 | 1 |
| 2: 08:01 | 113.11 | 100.24 | 92.21 | 87.06 | 2 |
| 2: 08:01 | 114.31 | 100.96 | 92.64 | 87.32 | 3 |
| 2: 08:01 | 112.51 | 99.88 | 91.99 | 86.93 | 4 |
| 2: 08:01 | 111.43 | 99.23 | 91.60 | 86.70 | 5 |
| 2: 18:00 | 104.66 | 94.53 | 88.14 | 83.97 | 1 |
| 2: 18:00 | 104.66 | 94.53 | 88.14 | 83.97 | 2 |
| 2: 18:00 | 105.26 | 94.89 | 88.36 | 84.10 | 3 |
| 2: 18:00 | 104.96 | 94.71 | 88.25 | 84.04 | 4 |

| Time | Current | 5-min | 10-min | 15-min | # Probes |
|----------|---------|--------|--------|--------|----------|
| 2: 22:58 | 117.53 | 101.94 | 92.25 | 86.13 | 1 |
| 2: 22:58 | 107.33 | 95.82 | 88.58 | 83.93 | 2 |
| 2: 22:58 | 104.93 | 94.38 | 87.72 | 83.41 | 3 |
| 2: 22:58 | 106.28 | 95.19 | 88.20 | 83.70 | 4 |
| 3: 03:04 | 98.17 | 87.74 | 81.17 | 76.89 | 1 |
| 3: 03:04 | 78.97 | 76.22 | 74.26 | 72.75 | 2 |
| 3: 03:04 | 72.37 | 72.26 | 71.88 | 71.32 | 3 |
| 3: 03:04 | 68.77 | 70.10 | 70.58 | 70.54 | 4 |
| 3: 03:04 | 77.77 | 75.50 | 73.82 | 72.49 | 5 |
| 4: 53:01 | 200.89 | 142.52 | 107.60 | 86.55 | 1 |
| 4: 53:01 | 195.49 | 139.28 | 105.65 | 85.38 | 2 |
| 4: 53:01 | 205.69 | 145.40 | 109.33 | 87.58 | 3 |
| 4: 53:01 | 208.69 | 147.20 | 110.41 | 88.23 | 4 |
| 4: 53:01 | 209.89 | 147.92 | 110.84 | 88.49 | 5 |
| 5: 43:17 | 227.09 | 157.44 | 115.55 | 90.32 | 1 |
| 5: 43:17 | 223.49 | 155.28 | 114.25 | 89.54 | 2 |
| 5: 43:17 | 237.89 | 163.92 | 119.44 | 92.65 | 3 |
| 5: 43:17 | 235.49 | 162.48 | 118.57 | 92.13 | 4 |
| 5: 48:25 | 262.39 | 178.52 | 128.10 | 97.74 | 1 |
| 5: 48:25 | 240.79 | 165.56 | 120.32 | 93.08 | 2 |
| 5: 48:25 | 226.39 | 156.92 | 115.14 | 89.97 | 3 |
| 5: 48:25 | 235.99 | 162.68 | 118.59 | 92.04 | 4 |
| 5: 48:25 | 231.91 | 160.23 | 117.12 | 91.16 | 5 |
| 6: 08:14 | 101.79 | 81.76 | 69.64 | 62.27 | 1 |
| 6: 08:14 | 104.19 | 83.20 | 70.50 | 62.79 | 2 |
| 6: 08:14 | 127.59 | 97.24 | 78.93 | 67.84 | 3 |
| 6: 08:14 | 117.69 | 91.30 | 75.36 | 65.70 | 4 |
| 6: 13:02 | 79.49 | 68.28 | 61.45 | 57.26 | 1 |
| 6: 13:02 | 69.29 | 62.16 | 57.78 | 55.05 | 2 |
| 6: 13:02 | 65.69 | 60.00 | 56.48 | 54.28 | 3 |
| 6: 13:02 | 73.49 | 64.68 | 59.29 | 55.96 | 4 |
| 6: 13:02 | 71.09 | 63.24 | 58.43 | 55.44 | 5 |
| 6: 48:33 | 45.79 | 47.36 | 48.20 | 48.61 | 1 |
| 6: 48:33 | 70.39 | 62.12 | 57.06 | 53.92 | 2 |
| 6: 48:33 | 66.79 | 59.96 | 55.76 | 53.14 | 3 |
| 6: 48:33 | 61.39 | 56.72 | 53.82 | 51.98 | 4 |
| 6: 48:33 | 59.59 | 55.64 | 53.17 | 51.59 | 5 |
| 6: 58:37 | 74.99 | 64.68 | 58.39 | 54.52 | 1 |
| 6: 58:37 | 67.19 | 60.00 | 55.58 | 52.84 | 2 |
| 6: 58:37 | 75.59 | 65.04 | 58.61 | 54.65 | 3 |
| 6: 58:37 | 67.19 | 60.00 | 55.58 | 52.84 | 4 |
| 6: 58:37 | 64.79 | 58.56 | 54.72 | 52.32 | 5 |

6 Conclusion

This study has compared actual probe travel times with travel-time predictions from the travel-time prediction algorithm. The comparisons were performed on four links on our study route. Two links with volume-capacity detectors were selected for detailed examination. TTP estimates and probe reports were also compared on two links which did not have detectors. In the detectorized and non-detectorized links chosen for study one link was highly congested during the peak periods and the other had far less congestion. This provided a mix of probe and detector data under varying traffic conditions which allowed a good overview of the TTP algorithm.

Both detector and probe data performed well during the off-peak period. During the peak period the detectors quickly became saturated and yielded unreliable travel-time predictions. This was especially true for Link 7 which was congested outside the predefined 4:00 to 6:00 pm peak period.

The probe-based predictions were more accurate but during the peak periods they also substantially underestimated actual travel times. This reflects the decision (to use a conservative travel-time prediction) made in the development of the algorithm but this evaluation suggests that it be adjusted to reflect these underestimations. In a subsequent deployment this adjustment can be made and the algorithm can produce more accurate predictions.

The present algorithm, however, performs exceptionally well when there is a small number of outliers during a five-minute time-of-day interval. These aberrations are largely ignored by the TTP as they should be. This was particularly evident in a case on Link 2 in which two probes in the same five-minute interval had travel times over five hundred seconds while all of the probes in the previous and subsequent intervals had travel times of one hundred seconds or less. The TTP forecasts did not pursue these isolated probe reports, demonstrating the value of the existing algorithm in treating this case.

Lastly, the effect of varying the number of probe reports during the five-minute intervals was examined. The probe data during these five-minute intervals represents the input to the TTP process and one would logically expect better results with more probe reports. While this is generally true we are more interested in the optimal number of probe reports. All intervals with at least four probe reports per interval were examined. Probe reports were then randomly deleted to determine the effects of decreasing the number of probe reports. This examination suggests that in most instances three probe reports are adequate to provide reasonable estimates. Increasing the number of probe reports to more than three caused very little change in the resultant travel-time forecasts. This finding is in concert with the findings of the frequency of probe reports study (see Sen, 1996) which indicated that the standard error of the mean travel times tends to stabilize after about three reports; the variance of travel times remains moderately high with additional probe reports and does not approach zero.

References

Berka S. Condie, H. and Sheffey A. (1996) *ADVANCE Evaluation: Detector Travel Time Conversion and Fusion of Probe and Detector Data*, Urban Transportation Center, University of Illinois, Chicago.

Berka S., Tian X. and Tarko A. (1995) *Data Fusion Algorithm for ADVANCE Release 2.0*, ADVANCE Working Papers Series, Number 48, Urban Transportation Center, University of Illinois, Chicago.

Liu N. and Sen A. (1995) *Travel Time Prediction Algorithm for ADVANCE, Release 2.0*, ADVANCE Working Papers Series, Number 47, Urban Transportation Center, University of Illinois, Chicago.

Mathes M. and Sen A. (1995) *Static Estimates of Travel Times in ADVANCE: Release 2.0 SPU Algorithm Report and Detail Design Document (#8600)*, ADVANCE Working Papers Series, Number 49, Urban Transportation Center, University of Illinois, Chicago.

Sen A. (1996) *ADVANCE Evaluation: Frequency of Probe Reports*, Urban Transportation Center, University of Illinois, Chicago.

Sen A., Condie H., Sheffey A., Xian T. and Zhu X. (1996) *ADVANCE Evaluation: Base Data and Static Profile*, Urban Transportation Center, University of Illinois, Chicago.

Urban Transportation Center (1995) *Travel Time Prediction and Performance of Probe and Detector Data: Evaluation Test Plan*, University of Illinois, Chicago.

Urban Transportation Center (1995) *Detector Travel Time Conversion and Fusion of Probe and Detector Data: Evaluation Test Plan*, University of Illinois, Chicago.

Glossary

Cycle Failure - see Signal Cycle Failure

Detector - Inductive loop detectors are deployed in the study area. These units are buried underground, within the road surface, and work on the principle that the passage of a vehicle on the road surface above causes a change in the induction of the loop.

Incident Detection (ID) - The detection at the TIC of activities on the roadway that significantly reduce the capacity of the roadway from the expected capacity at a particular time. The detection may be based on input from probes, fixed detectors, anecdotal sources, and such other data as may be available.

Mobile Navigation Assistant (MNA) - An in-vehicle navigation system designed and built by Motorola that determines vehicle position, performs route planning based on current traffic information, and provides dynamic route guidance information to the driver.

Off-Peak - that portion of the day considered to have lighter traffic flow, defined in the experiment as 1:00 pm — 4:00 pm.

Peak - that portion of the day considered to have heavier traffic flow, defined in the study as 4:00 pm — 6:00 pm.

Probe Vehicle - A vehicle equipped with the ADVANCE Mobile Navigation Assistant. The probe vehicle automatically reports travel times to the ADVANCE Traffic Information Center as it traverses the test area.

RF - Radio Frequency, the means by which probe vehicles communicate with the TIC.

Signal Cycle Failure - this happens when a vehicle arrives at a signal-controlled intersection during the red phase and waits through the whole of the following green phase without proceeding through the intersection.

Static Profile (SP) - static information of the roadway link including day type, link ID and average travel times for a specific time period.

Traffic Information Center (TIC) - Consisting of the hardware, software, a centralized facility and operations personnel. It communicates to and from probes and external systems.

Traffic Related Functions (TRF) - Subsystem consisting of data fusion, vehicle dynamics, incident detection and travel time prediction algorithms.

Travel Time Prediction (TTP) - An algorithm used in the prediction at the TIC of future short term travel times on links to develop future adjustments to the static profiles.

APPENDIX E

ADVANCE

**Advanced Driver and Vehicle
Advisory Navigation Concept**

Traffic Related Functions
Evaluation Report (5 of 7)
Documents # 8460.00

CONTAINS:

| | |
|--|---------------------------------|
| Base Data and Static Profile Evaluation Report | -- Document # 8460-01.01 |
| Data Screening Evaluation Report | -- Document # 8460-02.02 |
| Quality of Probe Reports Evaluation Report | -- Document # 8460-03.01 |
| Travel Time Prediction and Performance of Probe and Detector Data Evaluation Report | -- Document # 8460-04.01 |
| • Detector Travel Time Conversion and Fusion of Probe and Detector Data Evaluation Report | -- Document # 8460-05.01 |
| Frequency of Probe Reports Evaluation Report | -- Document # 8460-06.01 |
| Relationships among Travel Times Evaluation Report | -- Document # 8460-07.02 |

Prepared by
University of Illinois-Chicago
Urban Transportation Center

DISCLAIMER

This report was prepared by a contractor for
Argonne National Laboratory
and is published as it was received.

ADVANCE Evaluation

Detector Travel Time Conversion and Fusion of Probe and Detector Data

Stanislaw Berka, Helen Condie and Aaron Sheffey

URBAN TRANSPORTATION CENTER
University of Illinois at Chicago
1033 West Van Buren Street
Suite 700 South
Chicago, Illinois 60607

June 1996

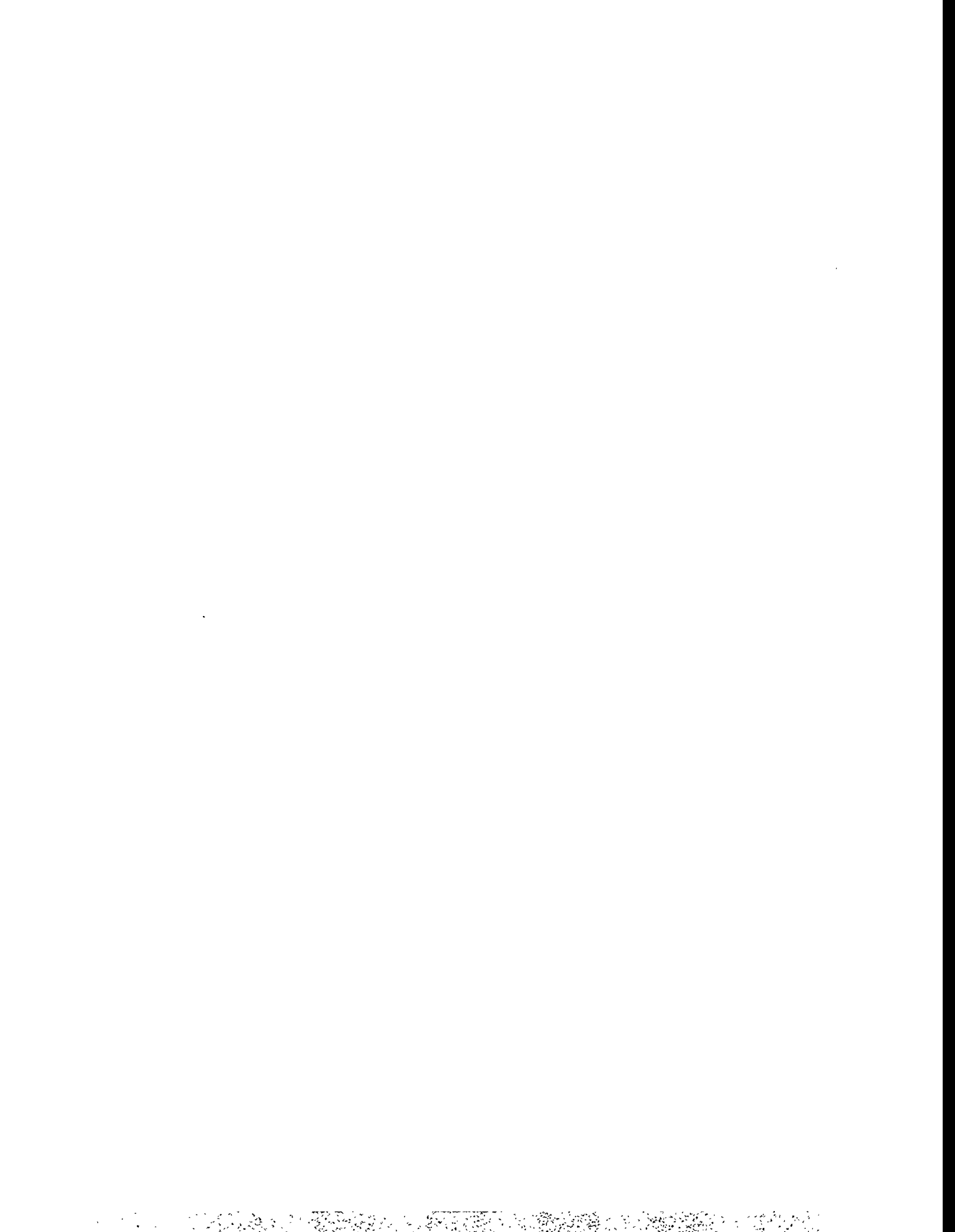

Executive Summary

This report concerns the evaluation of the conversion of detector data into travel-time estimates as well as the fusion of these estimates with probe reports to obtain travel-time estimates for specific links. These processes are called Detector Travel Time Conversion (DTTC) and Data Fusion (DF) respectively, and are parts of the Traffic Related Functions (TRF) subsystem of the ADVANCE project. Data from pavement loop detectors were collected and processed on-line to create travel-time estimates. These estimates were then fused with probe-vehicle reported travel times. The fused estimates provide travel-time data which would be used for dynamic route guidance.

Detectors record two traffic measures for each link: detector occupancy and vehicular volume. While applicable to other procedures, these measurements are not directly useful for route guidance. In the DTTC process, detector data were converted into travel times which could be fused with travel times recorded by probes. These DTTC-generated travel times were computed for five-minute intervals. These data, which are used in various ADVANCE evaluations, were reprocessed off-line into configurations matching those of the memory-card data, allowing for easy comparison and contrast. DTTC uses aggregated data, which are aggregated over all detectors within a given group by averaging occupancy and summing the volume. These data include two values, average occupancy and total volume, which are derived from paired detectors at parallel locations on a given link.

Probe data were also collected and then reformatted to retain only the information needed for this evaluation and only that data from the links under consideration. In addition, information manually collected by probe drivers concerning incidents was then appended to the data set. Finally, the data were reduced into a format chosen to facilitate analysis.

Once the data from both detectors and probes were assembled into usable formats, the DTTC algorithm was run. Then average probe travel times for each interval were developed for deployment levels of one, three and five; a deployment level refers to the number of probe reports randomly selected and utilized to compute the average travel times for a given link in that five-minute interval. This average was then fused with the estimate provided by DTTC. It is important to note that even for deployment levels lower than five, only intervals with five or more reports are used in this process, keeping the same number of intervals for all deployment levels. For instance, while only three probe reports are used to compute Deployment Level 3 averages, for each interval used in the evaluation there were still at least five reports for that link available. This equivalence is helpful in comparing the results of DTTC.

Based on the results of the evaluation, the estimates of the link travel times produced by DTTC and DF appear to be accurate except when overcongested conditions exist over long periods of time. During the overcongested period, the loop detectors do not provide information on changes in traffic conditions. It is conceivable that a more advanced semi-dynamic DTTC algorithm could be developed which would yield

reasonable estimates in this case, but it would require more data to be available for the calibration process than that which was available during the development of the TRF Data Fusion subcomponent of ADVANCE.

The comparison of the quality of the DTTC/DF estimates for various deployment levels suggests that the greatest improvement in using fused data, when compared to using DTTC output only, is visible for Deployment Level 3. However, for Deployment Level 1, the estimates are much better than those derived using DTTC output only, especially for those cases where the quality of the DTTC estimate is lower (as in the case of prolonged congestion).

Contents

| | |
|---|-----------|
| Executive Summary | i |
| 1 Introduction | 1 |
| 2 DTTC and the Data Fusion Algorithm | 2 |
| 2.1 Data Requirements | 2 |
| 2.2 Detector Travel Time Conversion Algorithm | 2 |
| 2.3 Data-Fusion Algorithm | 4 |
| 3 Probe Data Collection | 4 |
| 3.1 Study Routes | 4 |
| 3.2 Data-Collection Schedule | 5 |
| 3.3 Data Processing and Reduction | 7 |
| 4 Detector Data Collection | 7 |
| 4.1 Loop-Detector Location | 7 |
| 4.2 Data Processing and Data Reduction | 9 |
| 5 Evaluation Procedure | 10 |
| 6 Evaluation Results | 13 |
| 7 Results for DTTC: Detector Data Only | 14 |
| 7.1 Moderately-Congested Case | 14 |
| 7.2 Congested Case | 20 |
| 8 Results for DTTC Fused with Probe Data | 23 |
| 8.1 Moderately-Congested Case | 23 |
| 8.1.1 Deployment Level 1 | 23 |
| 8.1.2 Deployment Level 3 | 28 |
| 8.1.3 Deployment Level 5 | 28 |
| 8.1.4 Overall Analysis of Various Deployment Levels | 37 |
| 8.2 Congested Case | 38 |
| 8.2.1 Deployment Level 1 | 38 |
| 8.2.2 Deployment Level 3 | 41 |
| 8.2.3 Deployment Level 5 | 41 |
| 8.2.4 Overall Analysis of Various Deployment Levels | 46 |
| 9 Conclusions | 49 |

List of Figures

| | | |
|----|---|----|
| 1 | DTTC Conversion Model: Link 1 | 4 |
| 2 | Probe Data Collection: Long Route | 5 |
| 3 | Probe Data Collection: Short Route | 6 |
| 4 | Probe-Data Collection Route showing Detector Locations | 8 |
| 5 | Location of Loop Detectors Used in Data Collection | 9 |
| 6 | Flow Diagram of DTTC and DF Evaluation Procedures | 11 |
| 7 | Difference between Probe and Estimated Travel Time: Link 1, Off-Peak, Detector Data Only | 16 |
| 8 | Difference between Probe and Estimated Travel Time: Link 1, Peak, Detector Data Only | 17 |
| 9 | Difference between Probe and Estimated Travel Time: Link 11, Off- Peak, Detector Data Only | 18 |
| 10 | Difference between Probe and Estimated Travel Time: Link 11, Peak, Detector Data Only | 19 |
| 11 | Difference between Probe and Estimated Travel Time: Link 7, Off-Peak, Detector Data Only | 21 |
| 12 | Difference between Probe and Estimated Travel Time: Link 7, Peak, Detector Data Only | 22 |
| 13 | Difference between Probe and Estimated Travel Time: Link 1, Off-Peak, Deployment Level 1 | 24 |
| 14 | Difference between Probe and Estimated Travel Time: Link 1, Peak, Deployment Level 1 | 25 |
| 15 | Difference between Probe and Estimated Travel Time: Link 11, Off- Peak, Deployment Level 1 | 26 |
| 16 | Difference between Probe and Estimated Travel Time: Link 11, Peak, Deployment Level 1 | 27 |
| 17 | Difference between Probe and Estimated Travel Time: Link 1, Off-Peak, Deployment Level 3 | 29 |
| 18 | Difference between Probe and Estimated Travel Time: Link 1, Peak, Deployment Level 3 | 30 |
| 19 | Difference between Probe and Estimated Travel Time: Link 11, Off- Peak, Deployment Level 3 | 31 |
| 20 | Difference between Probe and Estimated Travel Time: Link 11, Peak, Deployment Level 3 | 32 |
| 21 | Difference between Probe and Estimated Travel Time: Link 1, Off-Peak, Deployment Level 5 | 33 |
| 22 | Difference between Probe and Estimated Travel Time: Link 1, Peak, Deployment Level 5 | 34 |
| 23 | Difference between Probe and Estimated Travel Time: Link 11, Off- Peak, Deployment Level 5 | 35 |

| | | |
|----|--|----|
| 24 | Difference between Probe and Estimated Travel Time: Link 11, Peak, Deployment Level 5 | 36 |
| 25 | Changes in Estimate Quality by Deployment Level, Moderately Congested Case | 37 |
| 26 | Difference between Probe and Estimated Travel Time: Link 7, Off-Peak, Deployment Level 1 | 39 |
| 27 | Difference between Probe and Estimated Travel Time: Link 7, Peak, Deployment Level 1 | 40 |
| 28 | Difference between Probe and Estimated Travel Time: Link 7, Off-Peak, Deployment Level 3 | 42 |
| 29 | Difference between Probe and Estimated Travel Time: Link 7, Peak, Deployment Level 3 | 43 |
| 30 | Difference between Probe and Estimated Travel Time: Link 7, Off-Peak, Deployment Level 5 | 44 |
| 31 | Difference between Probe and Estimated Travel Time: Link 7, Peak, Deployment Level 5 | 45 |
| 32 | Changes in Estimate Quality by Deployment Level, Off-Peak, Congested Case | 47 |
| 33 | Estimated Travel Time vs. Probe Travel Time: Link 7, Off-Peak, All Deployment Levels | 48 |

List of Tables

| | | |
|---|---|----|
| 1 | Parameter Values for Detector Data Conversion | 3 |
| 2 | MNA Reports by Link | 6 |
| 3 | Sample of Reduced Data Output | 10 |
| 4 | Input Conditions for DTTC and DF Simulation, as Specified in the Evaluation Test Plan | 12 |
| 5 | Standard Deviations of Probe Reports | 13 |
| 6 | Combination Inputs for DTTC and DF Simulations Selected for Evaluation | 14 |
| 7 | Summary Characteristics of Differences Between Travel-Time Estimates (Moderately-Congested Case) and Mean Probe Travel Times. | 38 |
| 8 | Summary Characteristics of Differences Between Travel-Time Estimates (Congested Case) and Mean Probe Travel Times. | 49 |

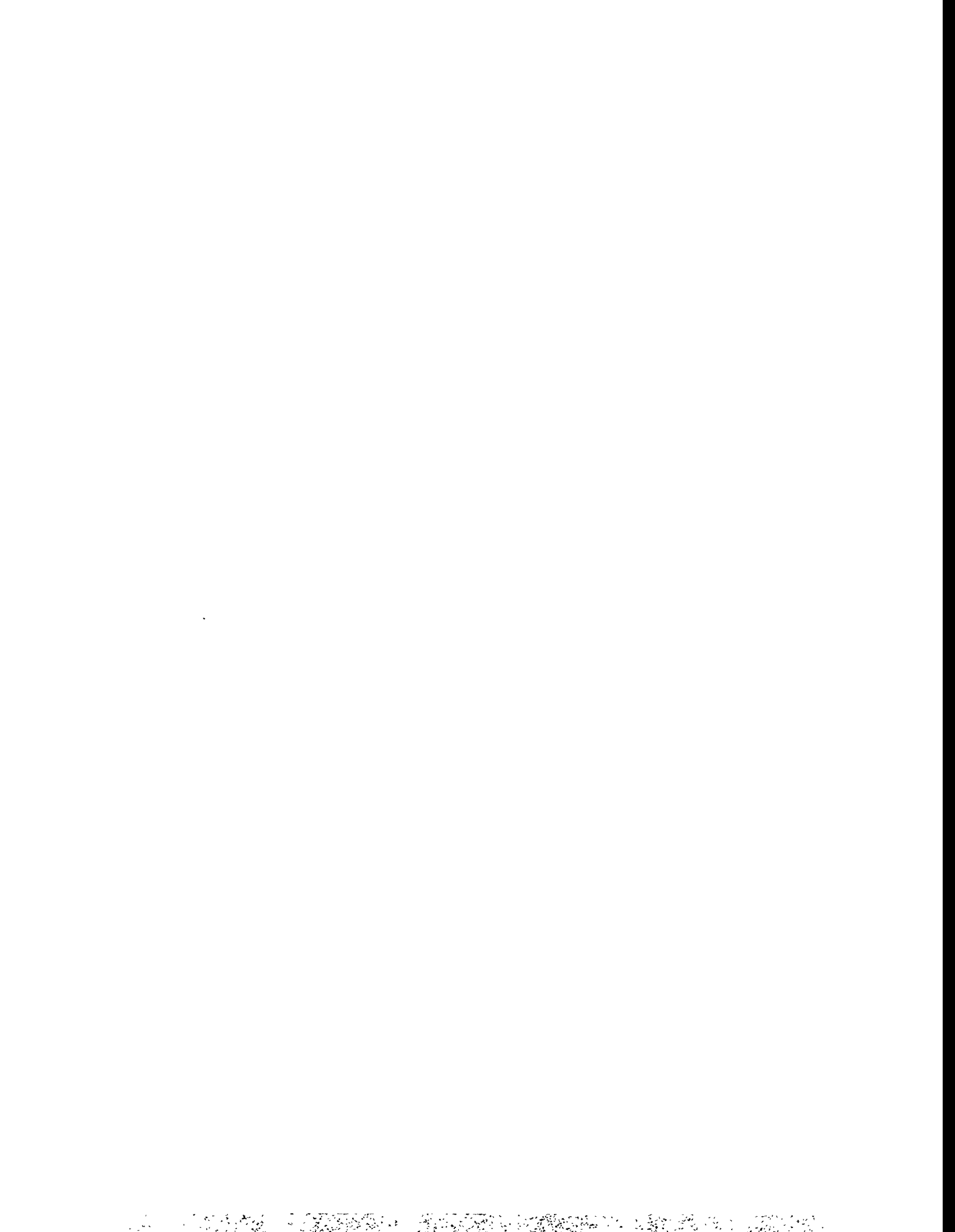

1 Introduction

This report concerns the evaluation of the conversion of detector data into travel-time estimates as well as the fusion of these estimates with probe reports to obtain travel-time estimates for specific links. These processes are called Detector Travel Time Conversion (DTTC) and Data Fusion (DF) respectively, and are parts of the Traffic Related Functions (TRF) subsystem of the ADVANCE project (see Berka, et al, 1995). Data from pavement loop detectors are collected by the Traffic Information Center (TIC), and are processed on-line to create the estimates. These estimates are then fused with travel times collected by the Mobile Navigation Assistant (MNA) within each probe vehicle. The MNA transmissions provide final travel-time data which would be used by the MNAs to construct alternate route choices. Another evaluation task (see Sööt and Condie, 1996) evaluates the accuracy of the probe-reported travel-time data.

For the evaluation of DTTC, we assume that the detector data are accurate. Since some errors occur, the evaluation results will account for these errors. In on-line ADVANCE operations, the data are first validated by another part of the TRF-DF module (for a description of data screening see Berka et al., 1996). For evaluation purposes, the data used are also filtered, except for the probe report data which are used as a source of the actual (average) travel times in assessing the accuracy of the estimates. These data are not filtered in order to avoid possible shortcomings of the filtering algorithm.

During the summer of 1995 approximately a dozen vehicles were driven four days a week over an eleven-week period. During this time almost 60,000 miles were driven to produce over 50,000 link reports within a confined study area. These reports provide information on at least three critical elements of travel: travel time, congested time and congested distance. Congested distance is measured in meters for each link and is the distance traversed by the probe vehicle at a speed of less than 10 meters per second (22.5mph). Congested time is measured in seconds and is the time during which the vehicle is stationary or traveling at a speed of less than two meters per second (4.4mph). This information is computed in the vehicle (also known as a probe) in its on-board MNA and is recorded in two different ways: in the vehicle (on a memory card) and in files at the Traffic Information Center (TIC) in Schaumburg, Illinois to which it is transmitted by radio frequency.

Data were collected on several study routes from June 5th to August 10th, Monday through Thursday. The original ADVANCE project design called for a massive probe deployment involving several thousand vehicles. This original vision was scaled back; this evaluation task uses data gathered from a targeted deployment of between 8 to 15 cars per day over a defined route. To simulate full deployment, the probes were sent more times over this route, thereby creating for each link a database of commensurate size to that envisioned in the original design. This data-collection exercise yielded 50,620 link travel-time reports at the TIC.

The route is located on Dundee Road and adjacent arterials, within the munic-

ipality of Wheeling, Illinois (north suburban Chicago). Dundee Road was selected because it carries a high volume of traffic and because each signalized intersection is demand-actuated by loop detectors (including turning lanes) and there are volume and occupancy detectors at several locations. Although Dundee Road extends for several miles within the ADVANCE study area, the number of potential places along Dundee Road where the necessary field tests could be performed was very limited. However, because Dundee Road is the only arterial within the ADVANCE test area with detectorized links feeding the data to TIC, these restrictions were accepted as part of the situation. The data-collection route also required a convenient location where vehicles could turn around safely and avoid being off the study route for a long period of time. As chosen, the route had a mix of link and intersection characteristics.

The first seven weeks of data collection (June 5—July 20) consisted of driving on set routes centered on Dundee Road. Data were collected, with one exception, from Monday to Thursday. For the DTTC evaluation, the data from the periods June 19—22 and July 17—20 were chosen; these two weeks contain the highest concentrations of MNA reports per link per time interval.

The report is organized as follows: the following section contains descriptions of the DTTC and DF algorithms. The next two sections are devoted to the probe and detector data, including further discussion of the data collection. The four subsequent sections describe the evaluation procedure and the results. The last section summarizes the results and draws conclusions about the DTTC and DF processes.

2 DTTC and the Data Fusion Algorithm

2.1 Data Requirements

Detectors record two traffic measures for each link: occupancy and volume. While applicable to other procedures, these measurements are not directly useful for MNA vehicle guidance. In the DTTC process, detector data are converted into travel times which can be fused with travel times recorded by probes. These DTTC travel times are computed for five-minute intervals.

The data-collection route had only three detectorized links. While detectors are also located along freeways, it was determined that arterial information would be the focus of this effort. At the vehicle density level described above, sufficient data were collected for the evaluation process. Sections 3 and 4 describe the collection of detector data and probe travel-time data, respectively.

2.2 Detector Travel Time Conversion Algorithm

The DTTC algorithm is copied here from Berka et al (1995) for completeness. The following list describes the algorithm by which link detector data are converted into travel-time estimates (t_d). In this protocol, the average loop detector occupancy (O_d)

over all available detector outputs for a given segment is converted into a travel time common to all links with that segment. The range of occupancies (O) for a detector is partitioned into intervals which are defined by parameters $O_{t,1}$ and $O_{t,2}$.

1. If the occupancy is lower than $O_{t,1}$, then $t_d = h_{11} + h_{12} \cdot O_d$, where: O_d = average occupancy over all detector outputs available for the segment, $O_{t,i}$ = break points in the travel time-detector data model, and h_{ij} = conversion parameter values.
2. If the occupancy is between $O_{t,1}$ and $O_{t,2}$, then $t_d = h_{21} + h_{22} \cdot O_d$.
3. If the occupancy is higher than $O_{t,2}$, then $t_d = h_{31}$.
4. If the travel time $t_d < t_{min}$, where $t_{min} = l/v_{max}$, then set $t_d = t_{min}$. If $t_d > t_{max}$, where $t_{max} = l/v_{min}$, then set $t_d = t_{max}$,

where:

- $O_{t,1}$ = 27% occupancy level;
- $O_{t,2}$ = 42% occupancy level;
- l = segment length (m);
- v_{max} and v_{min} = the upper and lower limits for travel speed (35 m/sec and 1 m/sec, respectively); and,
- t_{max} and t_{min} = the upper and lower bounds for link travel time.

Table 1 includes the parameter values required for converting arterial detector data into travel times for Links 1, 7 and 11. These values come from the calibration procedure, described in Berka and Tian (1994). An example of the conversion model can be seen in Figure 1.

Table 1: Parameter Values for Detector Data Conversion

| Link ID | ADVANCE Segment ID | h_{11} | h_{12} | h_{21} | h_{22} | h_{31} | σ_d |
|---|--------------------|----------|----------|----------|----------|----------|------------|
| 1 | 88cb2b | 59.73 | 2.53 | 136.10 | 0.00 | 123.56 | 39.99 |
| 7 | 88c9a8 | 70.49 | 1.62 | 110.58 | 0.13 | 116.09 | 38.42 |
| 11 | 8cae7 | 38.35 | 0.40 | 23.95 | 0.93 | 63.22 | 21.09 |
| [where σ_d = standard deviation of detector travel time (sec)] | | | | | | | |

[Note: the Link and ADVANCE Segment IDs are merely two systems used to designate identical links, and both are included for completeness.]

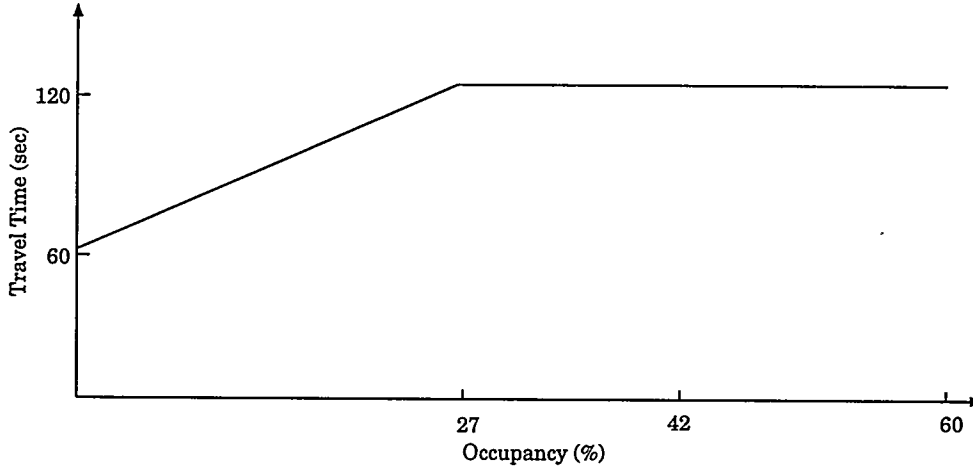

Figure 1: DTTC Conversion Model: Link 1

2.3 Data-Fusion Algorithm

Like the DTTC algorithm, the Data-Fusion Algorithm is copied here from Berka et al (1995) for completeness. Detector travel time t_d (converted from detector data) and mean probe travel time t_{pm} are fused together by the method of weighted averaging:

$$t_f = \frac{f_p \cdot \frac{N_p}{\sigma_p^2} \cdot t_{pm} + f_d \cdot \frac{W_d}{\sigma_d^2} \cdot t_d}{f_p \cdot \frac{N_p}{\sigma_p^2} + f_d \cdot \frac{W_d}{\sigma_d^2}}$$

where:

- t_f = fused travel time (sec);
- N_p = sum of weights of reasonable probe reports (-);
- t_{pm} = mean probe travel time (sec);
- σ_p = standard deviation of probe travel time (sec);
- W_d = weight assigned to detector travel time in data screening;
- t_d = travel time estimated from detector data (sec);
- σ_d = standard deviation of detector travel time (sec);
- f_d, f_p = fusion adjustment factors to control the contribution of each travel time source to the fused value.

3 Probe Data Collection

3.1 Study Routes

Two route configurations were used for the field data collection. The long route (Figure 2) consists of twelve links. The route was selected to be completed during a fifteen-minute period to provide the desired frequency of probe reports. During the off-peak

period the majority of the drivers completed this twelve-link route in ten to fourteen minutes.

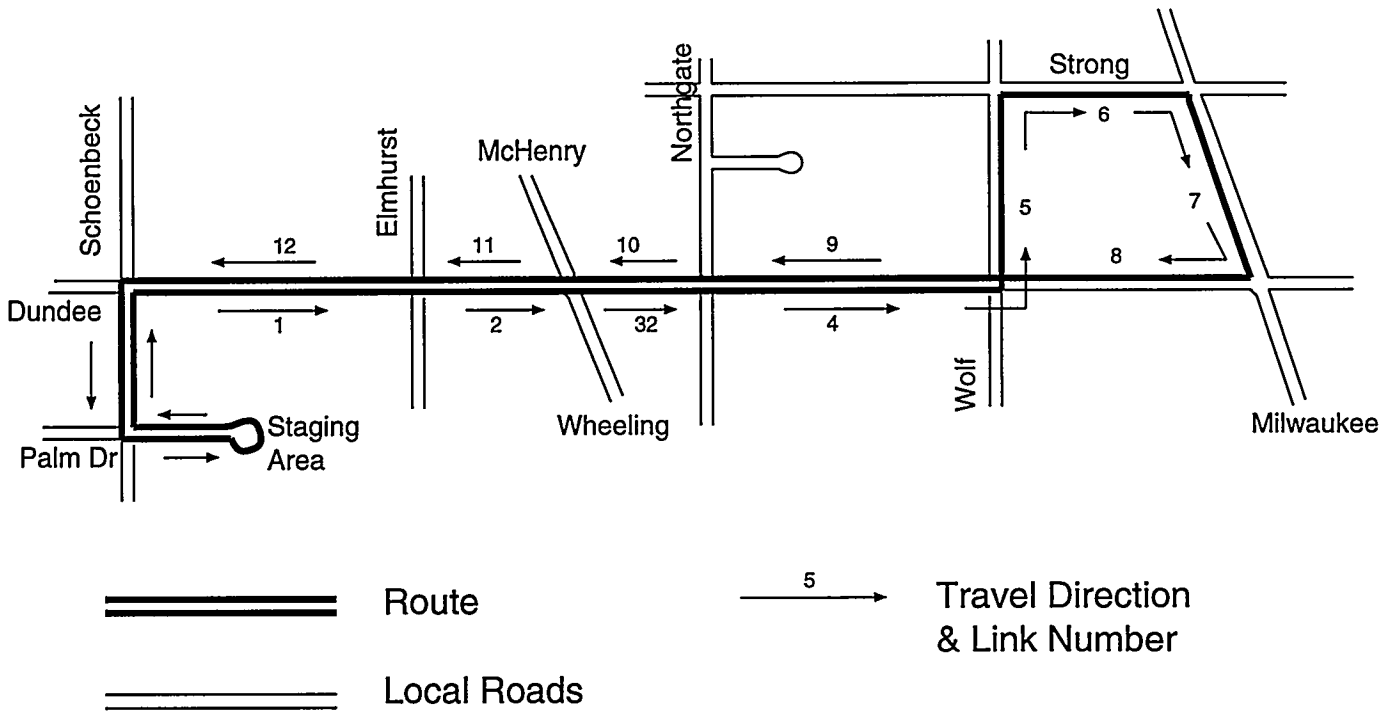

Figure 2: Probe Data Collection: Long Route

During the peak period this route proved to be too long to complete in fifteen minutes and a shorter alternative was used. This is shown in Figure 3. Even the short route could not always be completed in fifteen minutes but this happened infrequently.

The number of probe reports from each link on the two study routes is given in Table 2. In this evaluation of DTTC and DF we are concerned with Links 1, 7 and 11; it may be seen that Links 1 and 11, which feature in both the short and long routes, provide us with a greater number of probe reports than Link 7, which features in the long route only.

During the last three weeks of data-collection in the Dundee Road study area, the vehicles were used to test turning relationships. Unlike the earlier driving, in this case each driver was given a set of randomly drawn routes to be driven in sequence. Since the data-collection in the earlier part of the summer had gathered sufficient data, the turning data are not used in this evaluation of DTTC.

3.2 Data-Collection Schedule

At the beginning of each day of data collection, a twelve-noon briefing was held at the ADVANCE office in Schaumburg. At this time, the drivers were assigned vehicles and they left the office at approximately 12:30pm. Each driver used a designated

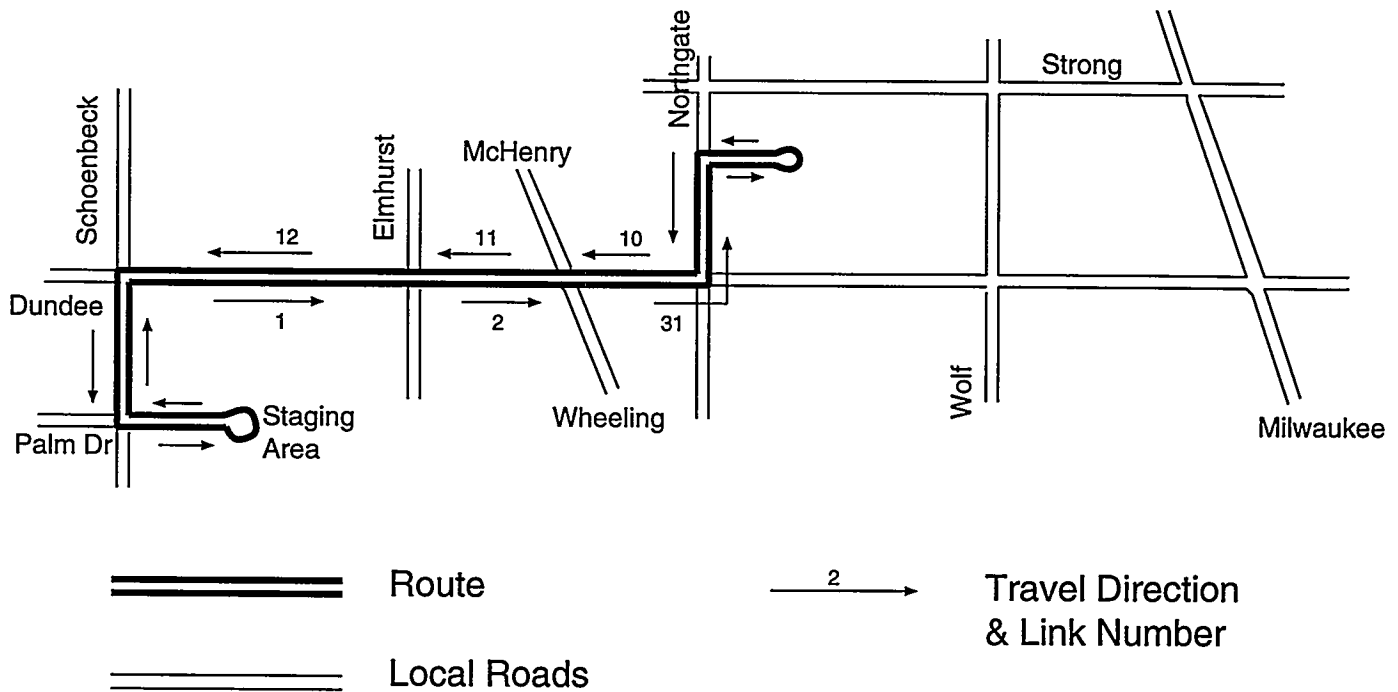

Figure 3: Probe Data Collection: Short Route

Table 2: MNA Reports by Link

| Link | Frequency | Percent | Link | Frequency | Percent |
|------|-----------|---------|-------|-----------|---------|
| 1 | 5481 | 10.8 | 7 | 2323 | 4.6 |
| 2 | 6298 | 12.4 | 8 | 2172 | 4.3 |
| 3* | 5886 | 11.6 * | 9 | 2462 | 4.9 |
| 4 | 2313 | 4.6 | 10 | 6066 | 12.0 |
| 5 | 2294 | 4.5 | 11 | 7826 | 15.5 |
| 6 | 2293 | 4.5 | 12 | 5206 | 10.3 |
| 31* | 3555 | 7.0 * | | | |
| 32* | 2331 | 4.6 * | | | |
| | | | Total | 50,620 | 100.0 |

* Link 3 consists of two links, 31 and 32. Link 31 is on the short route and includes a left turn at the end of the link. Link 32 is on the long route and has a through movement at the end of the link (no turn). For DTTC we are concerned with Links 1, 7 and 11.

route to drive to the study area. There were several different routes; this report is not concerned with the routes to and from the study area. Data were collected by probe vehicles driven in the study area between 1pm and 7pm, with breaks as described below.

On each day of data collection, a field manager was present at the staging area. The field manager ensured that vehicles were driving the study route at satisfactory headways and instructed drivers when to take breaks. The field manager also assisted with other problems which routinely occurred.

The drivers were given a ten-minute break from approximately 2:00pm to 2:10pm and another one from approximately 6:00pm to 6:10pm. Since each driver was dispatched by the field manager to the break area as they arrived at the staging area, each took his or her break at a slightly different time. During breaks each probe vehicle was inactive for more than ten minutes because time was lost both off-route and while the MNA warmed up. The longest break occurred from 3:30pm to 4:00pm. During the two-hour peak period from 4:00pm to 6:00pm, the drivers operated their vehicles without scheduled breaks.

3.3 Data Processing and Reduction

Data received from probe MNA reports were reformatted to retain only the information needed for this evaluation and only that data from those links on the routes shown in Figures 2 and 3. Information manually collected by probe-vehicle drivers concerning incidents was then appended to the data set. Finally, the data were reduced into a format chosen to facilitate analysis.

4 Detector Data Collection

4.1 Loop-Detector Location

Two types of in-ground loop detectors are present on selected intersection approaches on the Dundee Road study routes. Their locations are shown in Figure 4. These are parts of two Closed Loop Systems. System detectors (detectors A and B in Figure 5) are located 250-300 feet upstream of the intersection; approach detectors (C, D and E in Figure 5) are located just upstream of the stop line. While both types of detector measure traffic volume and occupancy, DTTC only uses information from the system detectors, A and B. The two detector groups are used to actuate traffic signals, allowing for coordinated green times and continuous traffic flows along Dundee Road. Because of the presence of other arterials leading into Dundee Road, detector data also help coordinate traffic flows among these other roads. Detectors are generally placed in parallel positions along a link, as seen in Figure 5.

Information is collected from system loop detectors for each Closed Loop System (type Econolite KMC-1000 controllers), which begin data transmission back to the

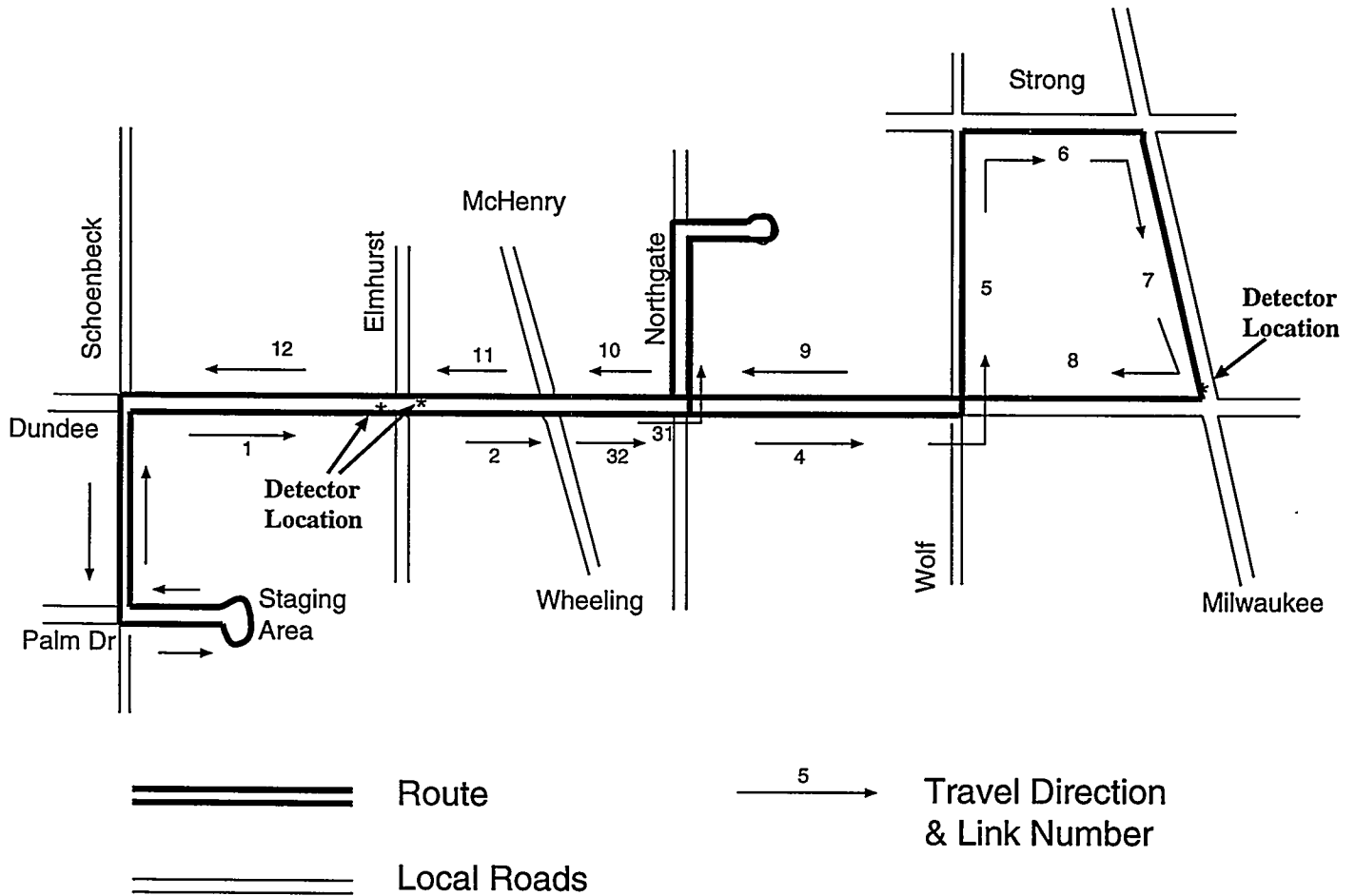

Figure 4: Probe-Data Collection Route showing Detector Locations

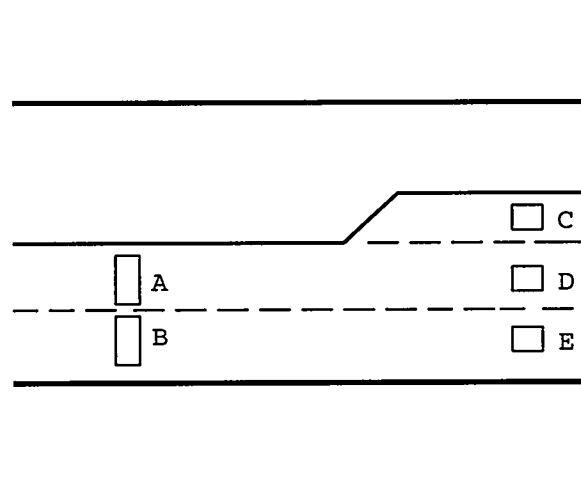

Figure 5: Location of Loop Detectors Used in Data Collection

Note: A through E represent in-ground detector locations, detectors A and B are used for DTTC

TIC. These data, along with information sent in from the MNAs in the probe vehicles [transmitted to the TIC using radio frequency (RF)], constitute part of the TIC's communications subsystem. These data are sent through the Illinois Department of Transportation's (IDOT) standard menu interface for loop-detector data and are transmitted by IDOT's Traffic Systems Center (TSC) communications software via modem to the TIC. Detector data are sent at five-minute intervals, containing the information which is discussed in Section 4.2. TSC has multiple data configurations, which can be varied depending on what types of data are being collected. As recorded by the TIC, these data have a dual nature, and are stored in both statically and dynamically-generated formats. Data collected in this fashion are used on-line for ADVANCE project tasks and are then archived.

4.2 Data Processing and Data Reduction

Unlike other types of data collection in the ADVANCE Project, detector data collection was completely dependent on an outside source: IDOT. Detector data collection is wholly conducted by IDOT, with information only sent to the TIC after collection and assimilation by a third party.

Detector data are sent in five-minute intervals to the TIC. These data are then processed on-line into usable configurations. Data for use in ADVANCE evaluations are then reprocessed off-line into configurations matching those of the MNA and memory-card data, which allows for easy comparison and contrast. There are two basic forms for detector data, detector-by-detector and aggregated. Detector-by-detector data contain

separate reports, each containing volume and occupancy, for each detector. Aggregated data are detector data aggregated over all detectors within a given group by averaging occupancy and summing the volume; this process creates a data set providing one report per five-minute interval. DTTC uses aggregated data, which includes two values [average occupancy (occ_{ag}) and total volume (vol_{ag})] derived from both detectors at parallel locations on a given link.

The data are first organized into a database. As part of this process, the data are reduced, eliminating links not within the route area under consideration. Data reduced in this fashion produce a data set similar in format to that shown in Table 3, taken from the output for August 1, 1995. Detector data are reduced to only include those detectorized links (1, 7 and 11) within the routes shown in Figure 4.

Table 3: Sample of Reduced Data Output

| Date m/d/yr | Time | Traffic Volume | Occupancy (%) | Link ID (hex) | Link ID | Detector Station Name |
|----------------|---------|----------------|------------------|---------------|---------|-----------------------------|
| 8 1 95 | 13 2 27 | 72 | 16 | "8cae7" | 11 | "DU_W_83" |
| 8 1 95 | 13 2 27 | 60 | 9 | "88c9a8" | 7 | "DU_S_MILWK" |
| 8 1 95 | 13 2 27 | 91 | 25 | "88cb2b" | 1 | "DU_E_83" |
| 8 1 95 | 13 2 27 | 64 | 25 | "88c9a8" | 7 | "DU_S_MILWK" |
| 8 1 95 | 13 2 27 | 83 | 19 | "88cb2b" | 1 | "DU_E_83" |
| 8 1 95 | 13 2 27 | 67 | 6 | "8cae7" | 11 | "DU_W_83" |

5 Evaluation Procedure

There are two distinct data assembly procedures for our analysis: that using detector data only and that using detector data and probe data. We compare both detector travel time conversions (the output of DTTC, using detector data only) and fused travel times (the output of the fusion of probe data and DTTC) with average probe travel times.

The evaluation procedure for analysis using fused detector data and probe data is depicted in full in Figure 6. For analysis using detector data only the output of DTTC (Step 5 on Figure 6) is compared with mean probe travel time; data fusion is not performed.

Data for DTTC (i.e., detector data) are divided into five-minute intervals so that there is exactly one detector report per interval. Five-minute intervals are used because detectors only transmit data in five-minute intervals. Data for use in analysis using both detector and probe data are also assembled into five-minute intervals; in this case, an interval is only created when at least five probe reports for the same interval are available for the same link (see following).

Data Used for Evaluation of DTTC and DF

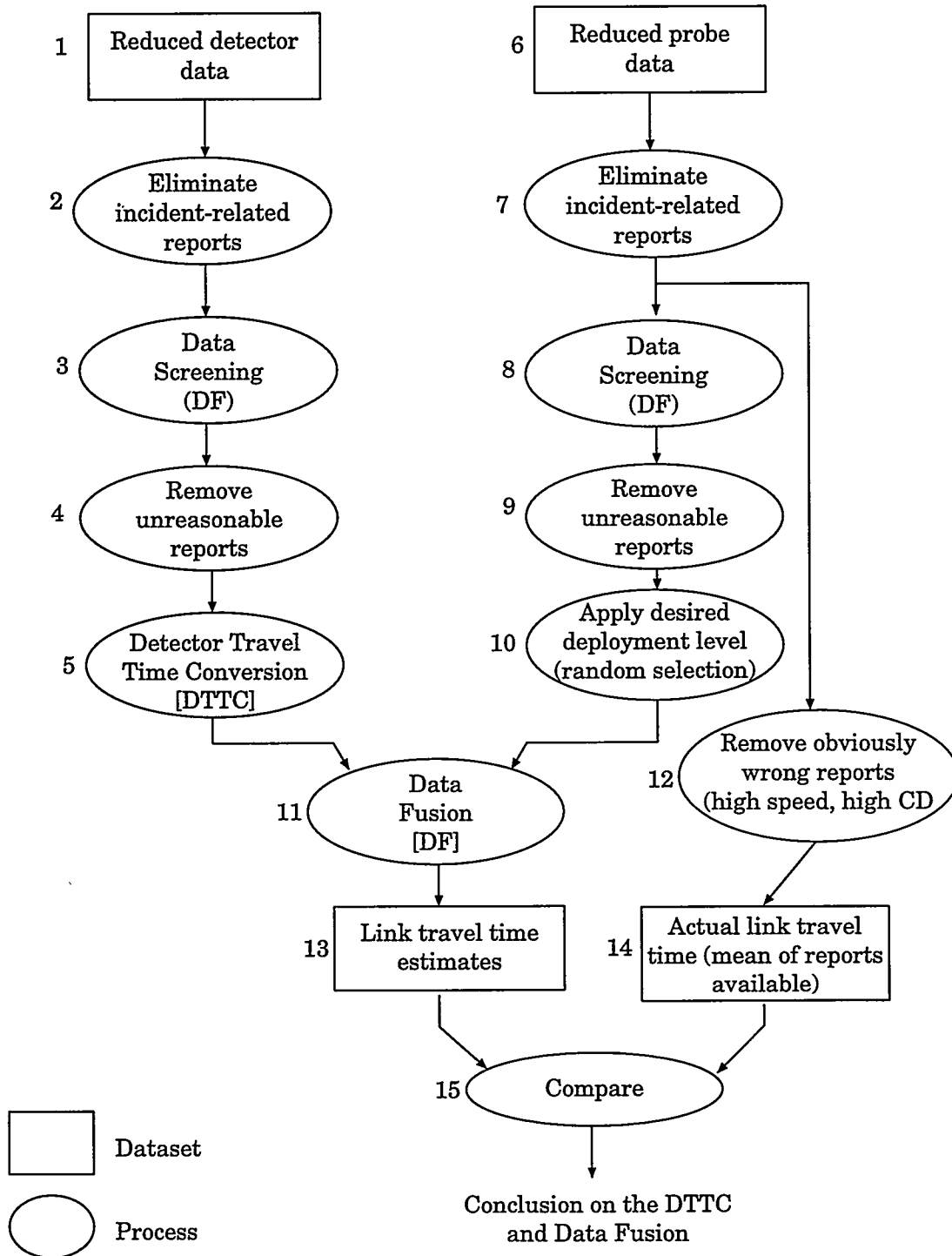

Figure 6: Flow Diagram of DTTC and DF Evaluation Procedures

Three steps are performed in parallel for both detector and probe data, including the elimination of incident-related reports, data screening as developed for the TRF Data Fusion (DF) subcomponent, and the elimination of reports determined by the data-screening algorithm to be unreasonable. These three steps describe the two threads in Figure 6 (2-3-4 and 7-8-9).

In the DTTC procedure, average volume and occupancy are computed using detector data as assigned to each interval. For analysis using fused detector and probe data, an additional step (Step 10 on the flow chart) is performed on probe data. Average probe travel times for each interval are developed for deployment levels of 1, 3 and 5; a deployment level refers to the number of probe reports randomly selected and utilized to compute the average values for a given link in that five-minute interval (see Section 6). It is important to note that even for deployment levels lower than 5, only intervals with five or more reports are used in this process, keeping the number of intervals the same for all deployment levels. For instance, while only three probe reports are used to compute Deployment Level 3 averages, there are still at least five reports available for that link for that time period. This equivalence is helpful in comparing the results for different deployment levels. These interval data are then used as the inputs for the data fusion procedure.

Seven deployment levels are suggested by the Evaluation Test Plan (ETP), as specified by Table 4; deployment levels used in our analysis are described in detail in the next section. While the ETP suggests analyses for the evening period (6pm–8pm) and for those links controlled by stop signs and for approaches to major-minor priority links, no data are available for these conditions (marked with square braces in Table 4). Evaluation is therefore not possible for these additional cases.

Table 4: Input Conditions for DTTC and DF Simulation, as Specified in the Evaluation Test Plan

| Probe Deployment Level (observ/inter) | Time Period | Link Class |
|---------------------------------------|-------------|-----------------------|
| 0 | 1pm-4pm | unopposed, signal |
| 1 | 4pm-6pm | [opposed, stop sign] |
| 2 | [6pm-8pm] | [unopposed, priority] |
| 3 | | |
| 4 | | |
| 5 | | |
| +5 | | |

The detector data are converted into link travel-time estimates using the TRF-DTTC algorithm (see Section 2.2). For analysis using probe and detector data, the travel-time estimates which are the output of the DTTC procedure are fused with probe reports, simulating the desired levels of probe deployment by randomly filtering the

probe reports for the interval considered, as noted above. The data fusion algorithm is described in Section 2.3. Standard deviations used in the fusion process are presented in Tables 1 and 5 for detector-based, travel-time estimates and probe reports, respectively. Values in Table 5 are obtained from the output of the Static Profile Update (Sen et al., 1996).

Table 5: Standard Deviations of Probe Reports

| | Link | Data from Period: June 19-22 | Data from Period: July 17-20 |
|----------|------|---------------------------------|---------------------------------|
| Off-Peak | 1 | 41.00 | 24.93 |
| | 7 | 79.18 | 46.92 |
| | 11 | 48.45 | 83.11 |
| Peak | 1 | 38.74 | 26.34 |
| | 7 | 447.25 | 133.41 |
| | 11 | 54.24 | 21.31 |

Using all available probe reports for the same time interval as a reference point, the estimates are assessed for accuracy (Step 14 in Figure 6). Probe reports used in this step were processed to eliminate incorrect reports. The deleted reports included those which had excessively high or low travel times which could not be correct.

6 Evaluation Results

The following sections present the results of the evaluation obtained using the procedures described in the previous section. The results for different time-of-day periods, various probe-deployment levels (including deployment level 0, i.e., detector data only) and links are presented graphically in Figures 7 through 24 and 26 through 31. The results of the analysis are presented for two cases; the moderately-congested case refers to Links 1 and 11 and the congested case refers to Link 7. Each of the twenty-four figures follows the same format, with a scattergram at the top of the page and a histogram below. The scattergrams reflect the five-minute data, representing five-minute intervals. The mean probe travel times for the five-minute intervals are on the y-axis and the travel time estimates generated by the DTTC and DF are on the x-axis. The line reflecting equal values of x and y is drawn to help assess how closely the estimates mimic the average travel time. Ideally, all circles would be concentrated along this line.

The histogram in each figure shows the frequency distribution of the difference between the estimated travel time and the probe reported travel time for each five-minute interval. The height of one bar represents the number of reports for which the difference between the probe and estimated travel time is within a narrow range as defined by the x-axis. An ideal procedure would be represented by a few high bars

concentrated around zero.

Out of all the possible simulations of the DTTC and DF defined by the selection of one entry from each input condition in Table 4, only the scenarios presented in Table 6 are analyzed. Used throughout the report, the term *vehicle deployment level* can be explained as follows: Deployment Level N means that for each five-minute interval analyzed, exactly N probe reports are used as input to the DF process. Deployment Level 0 is used to denote the case when the travel-time estimates are based on the DTTC output only, that is, no probe reports are fused with DTTC output. A desired deployment level is obtained within the evaluation procedure by selecting all intervals with at least five (5) probe reports, out of which n reports are *randomly selected*. The exception is Deployment Level 0 where all intervals with any number of probe reports are used for the analysis (although the probe reports themselves are not used in the process).

Table 6: Combination Inputs for DTTC and DF Simulations Selected for Evaluation

| Time Period | Deployment Level* | Corresponding Figure # (for Links 1, 11 and 7) |
|---------------------|-------------------|---|
| Off-Peak (1-4pm) | 0 (detector only) | 7, 9, 11 |
| | 1 | 13,15,26 |
| | 3 | 17,19,28 |
| | 5 | 21,23,30 |
| Peak (4-6pm) | 0 (detector only) | 8, 10,12, |
| | 1 | 14,16,27 |
| | 3 | 18,20,29 |
| | 5 | 22,24,31 |

7 Results for DTTC: Detector Data Only

The evaluation results presented in this section are divided into two groups, moderately-congested links (Links 1 and 11) and congested links (Link 7). Data analyzed in this section were assembled using the procedure described above; that is, there is only one detector report per five-minute interval. Travel-time estimates based on these detector data are compared with probe data travel time averages for accuracy.

7.1 Moderately-Congested Case

Results for this case (Links 1 and 11) are presented in Figures 7 through 10. The detector occupancy used to estimate the travel times are rounded in the detector controller to the nearest integer number and are then transferred in this form to TIC. Integer values converted by a conversion model like the one in Figure 1 give discrete

values as shown in Figures 7 through 10. Generally, the scattergrams in these four figures are similar. A visual analysis of the quality of the DTTC estimates, based on the histograms in Figures 7 through 10, shows that the estimate typically differs from the actual probe travel time by less than 50 seconds.

While Link 1 during the off-peak and peak periods (scattergrams on the upper half of Figures 7 and 8) has the same range of mean travel times, the estimated travel times for the peak period are lower. Several of the estimates reach 100 seconds for the off-peak period but only one estimate exceeds 85 seconds for the peak period. This fact, while counterintuitive, can be explained. Link 1 is not saturated, either during the peak or off-peak periods, so the travel time is about the same for both cases. However, during the off-peak period (1-4pm) there is more east-bound traffic (Link 1 is east-bound) than during the peak period, when the majority of the traffic is west-bound, outward from Chicago. As a result, Link 1's occupancy and the resulting travel-time estimate for the off-peak period are higher than those for the peak period.

The explanation given above can be verified by using a west-bound example of Link 11. If the explanation is true, we would expect the opposite situation than for Link 1; that is, we would expect the estimated travel time to be higher for the peak period. Indeed, the mean travel times for Link 11 for both off-peak and peak periods lie in approximately the same range, but now the peak estimated travel time is slightly higher. Several of the peak estimates exceed 50 seconds (top half of Figure 10) while only one off-peak estimate exceeds 50 seconds (top half of Figure 9). The higher range of travel-time estimates for Link 11 in the peak period follows the more intuitive pattern of higher travel times during the peak period, the principal reason being that Link 11 is west-bound and carries the afternoon peak traffic from Chicago and its inner suburbs to the outlying suburbs.

The lower occupancy and corresponding travel-time estimates for the peak period on Link 1 (compared to the off-peak estimates) have a further explanation. The traffic signal at the downstream end of Link 1, like most signals in this area, is demand-actuated (dynamically adjusted to adapt to the changing traffic conditions). Roughly speaking, the street with the heavier traffic gets the longer green time. Because the traffic on Dundee Road (and Elmhurst, its cross-street) is heavier during the peak period than during the off-peak period, it gets more green time during the former than the latter. The occupancy depends not so much on the traffic volumes themselves as on the ratio of volume to capacity of the approach, this capacity being an increasing function of green time. For this reason, even if the volume on Link 1 is slightly higher during the peak period than off-peak, the volume-to-capacity ratio will be lower. Therefore, the travel-time estimate based on the corresponding occupancy figure derived from the detectors will also be lower, as seen on upper parts of Figures 7 and 8. This relationship points to the quality of the DTTC estimates. On Link 11, the green time is higher during the peak period (for the same reason as for Link 1), but the volume is significantly higher during the peak period.

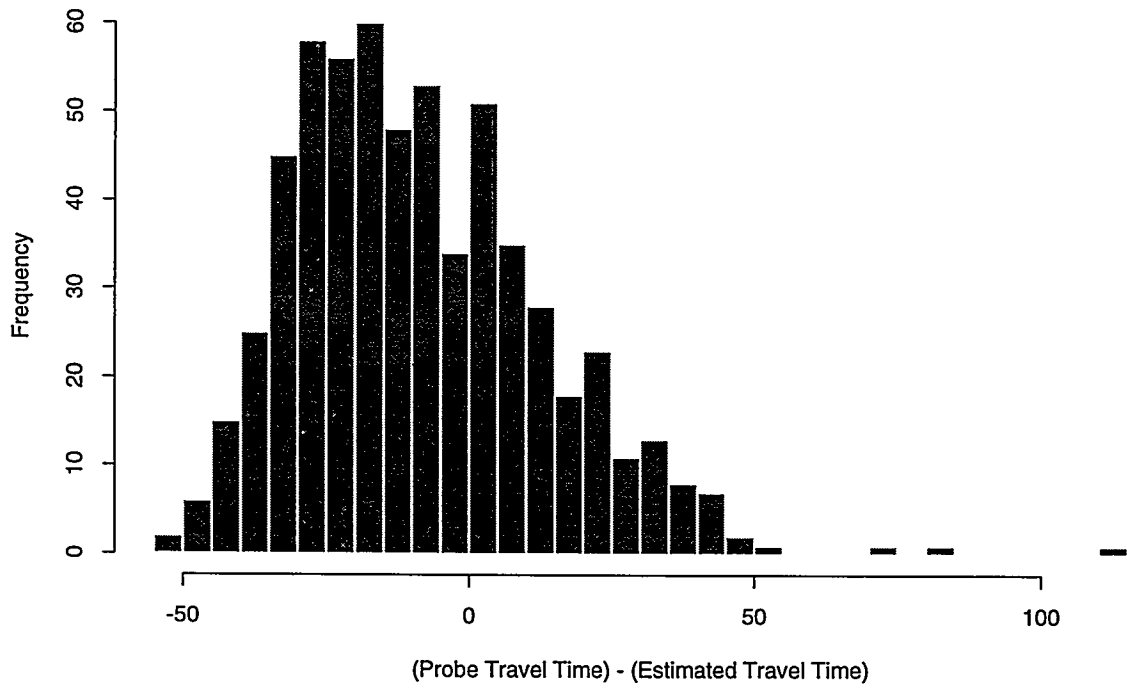
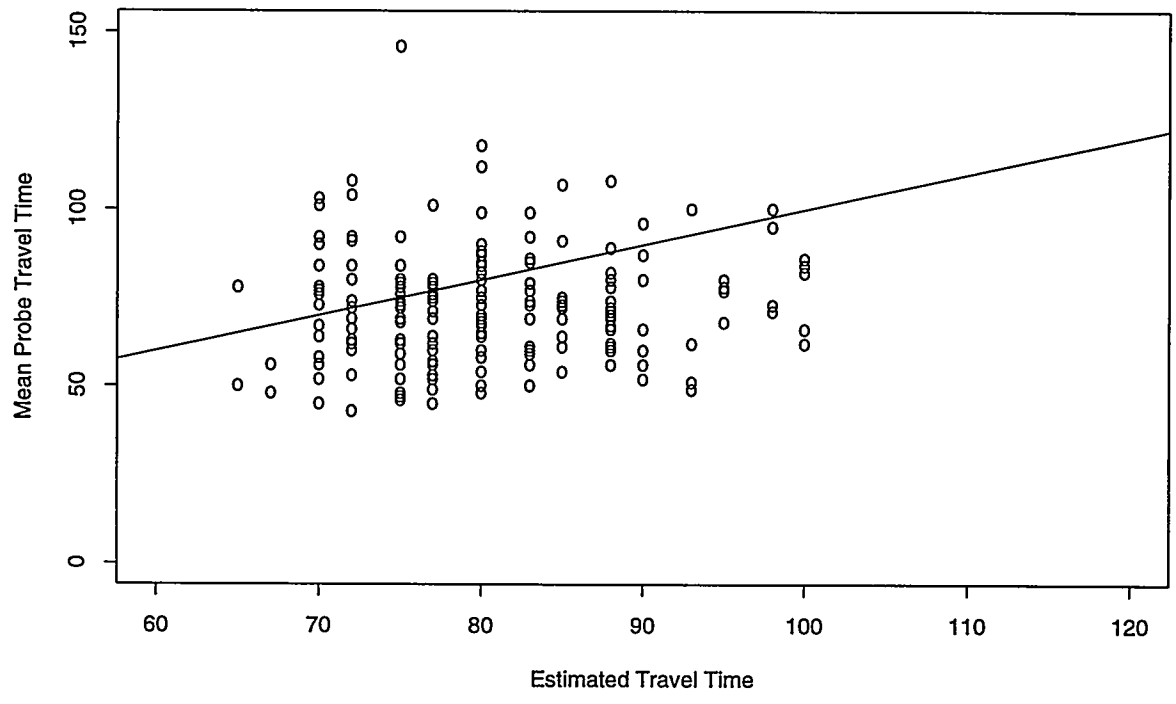

Figure 7: Difference between Probe and Estimated Travel Time: Link 1, Off-Peak, Detector Data Only

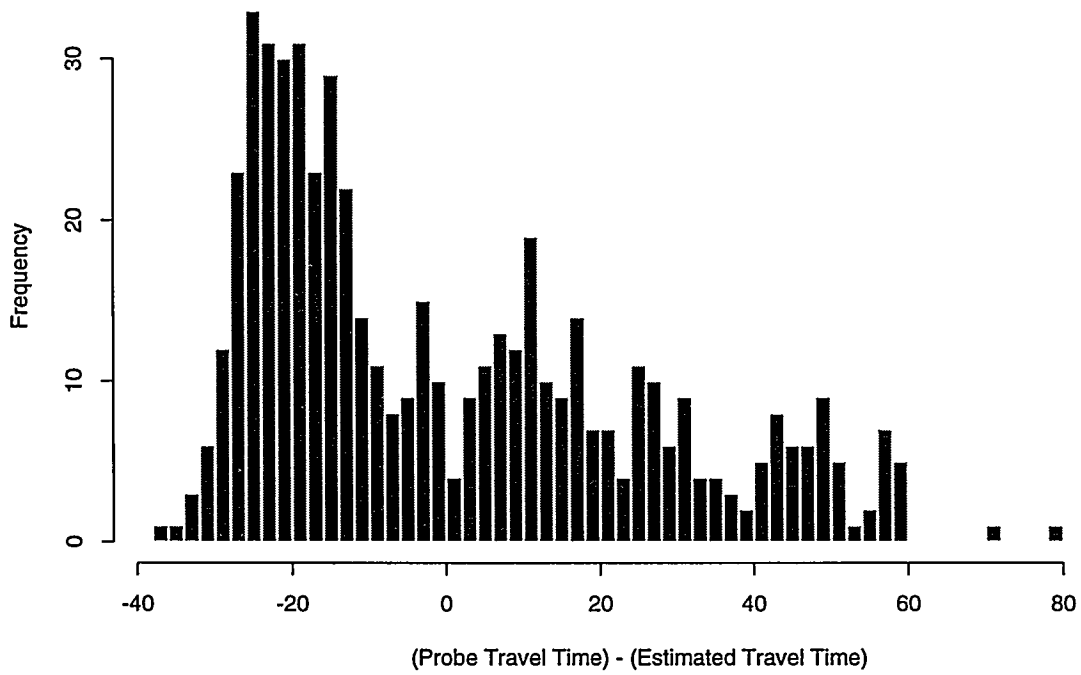
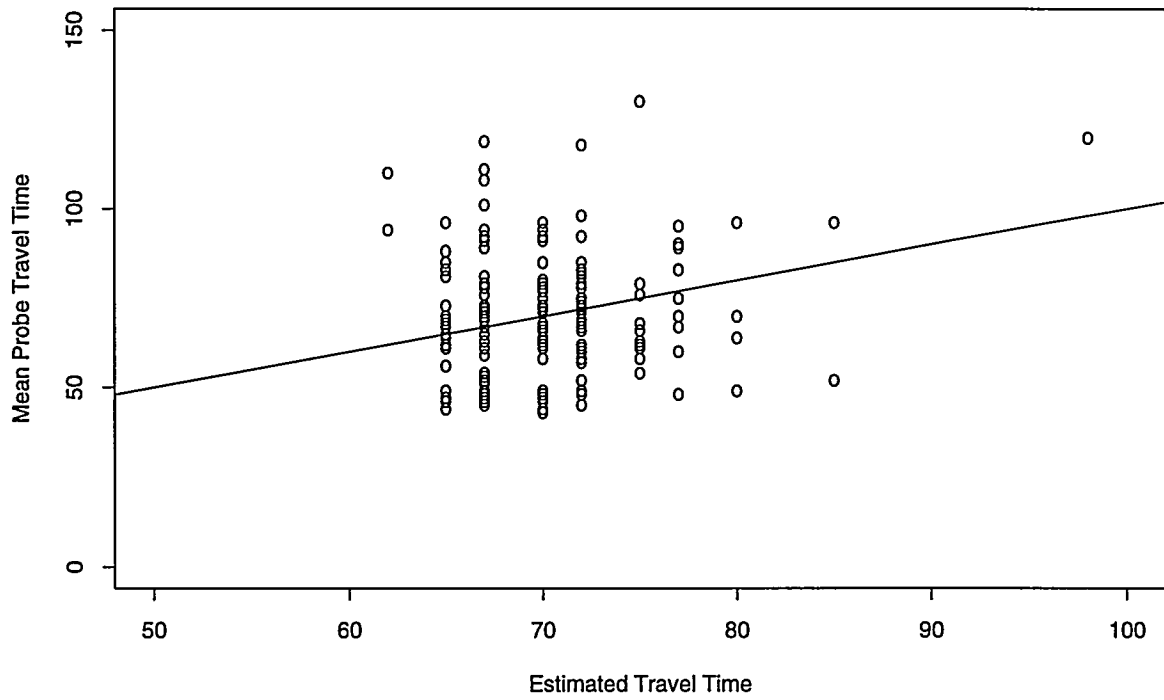

Figure 8: Difference between Probe and Estimated Travel Time: Link 1, Peak, Detector Data Only

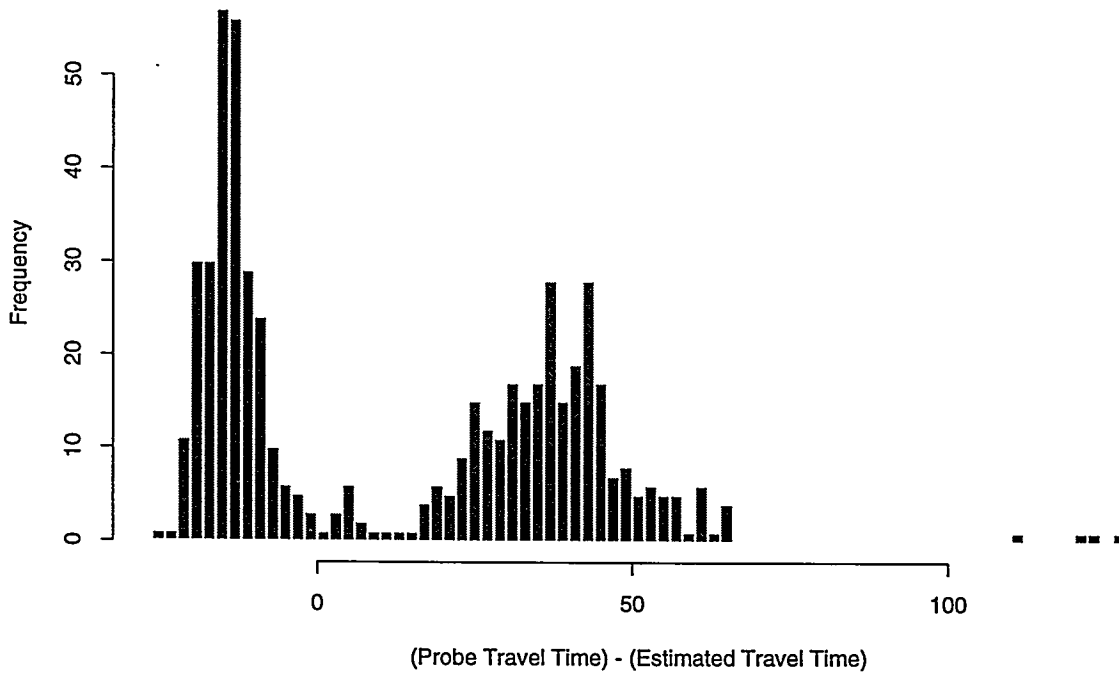
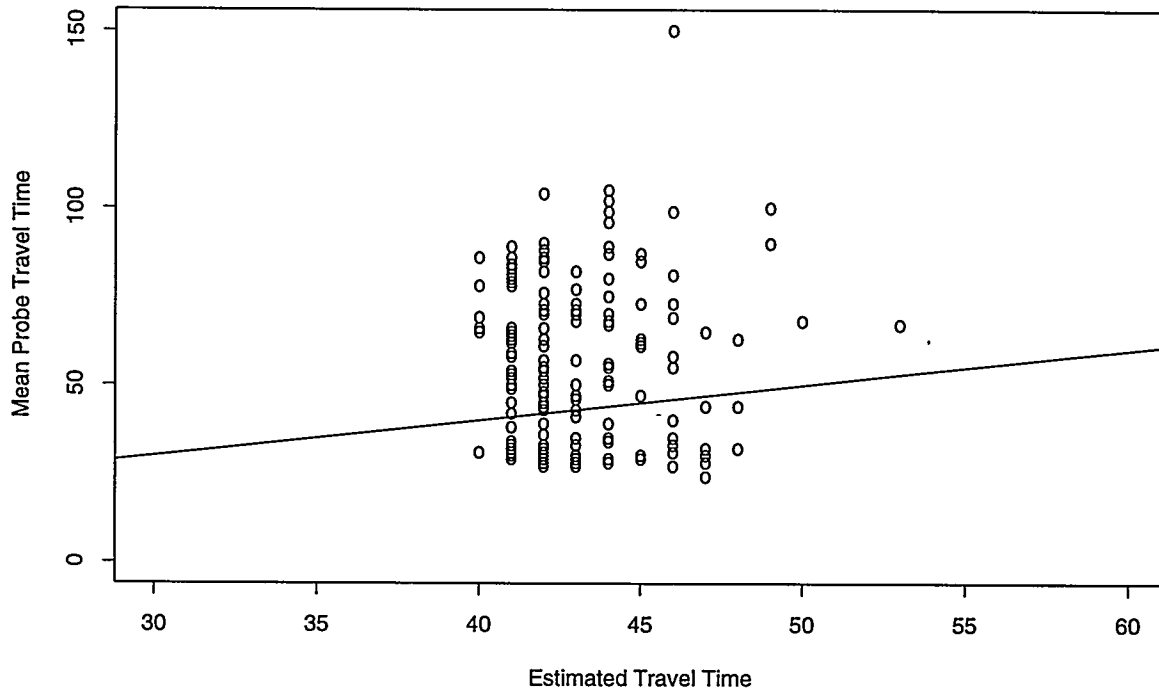

Figure 9: Difference between Probe and Estimated Travel Time: Link 11, Off-Peak, Detector Data Only

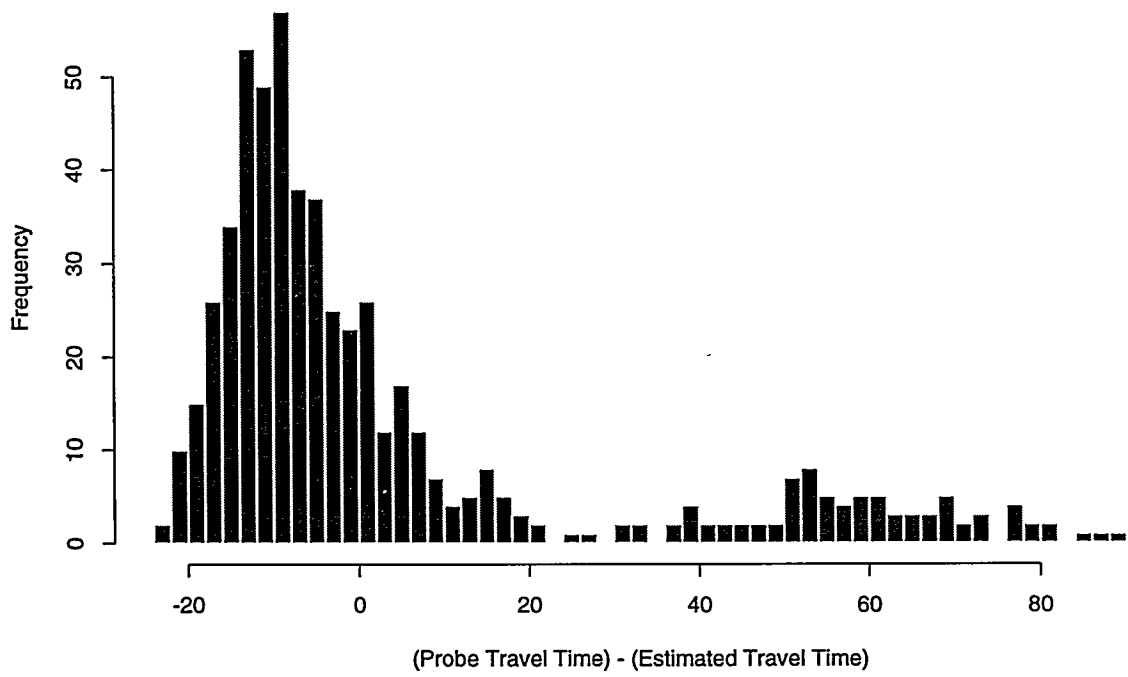
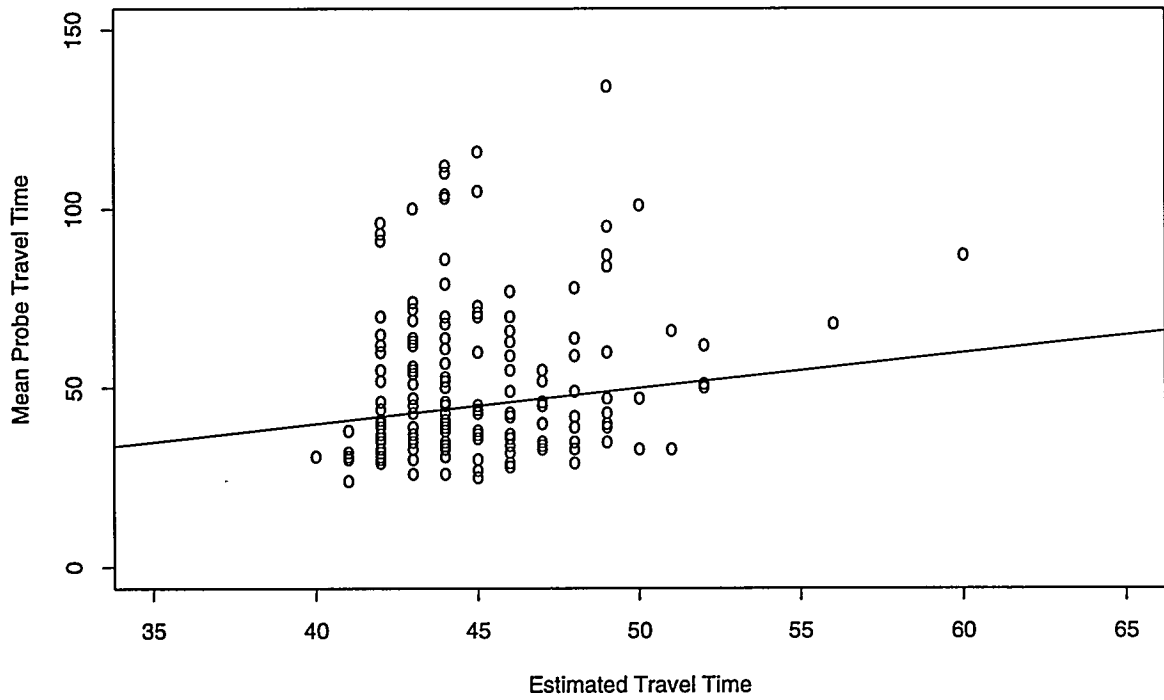

Figure 10: Difference between Probe and Estimated Travel Time: Link 11, Peak, Detector Data Only

7.2 Congested Case

This section discusses the results for the congested case (Link 7), for both the off-peak (Figure 11) and peak periods (Figure 12).

On both scattergrams we observe two distinct groups of points. The first group consists of observations located along the line $x = y$, which for the off-peak period includes the majority of the observations. For the first group of points actual and estimated travel times roughly correspond. The second group of points is substantially different: the mean travel times are much higher than the corresponding estimates; these points are grouped together in a vertical line. Overall, while evidencing less correspondence between the probe averages and the DTTC estimates than those in the off-peak scattergram, the points plotted in the peak scattergram still show correspondence between the averages and the estimates. Therefore, the quality of estimates from the first group of points for both periods is still quite good even though its quality is slightly lower than that of the off-peak estimates for Link 1.

The peak-period case for Link 7 can be explained by the fact that during the peak period the approach of Link 7 is highly congested with the queue frequently spilling back into the upstream link. Importantly, the queue for most of the 4-6pm period is much longer than the loop-detector setback (about 300 feet). Thus, the occupancy measured by the detector is more or less constant as long as over-congestion persists. This deduction is valid assuming that the green and red times do not change, a condition satisfied by Link 7 during the peak period. Therefore, the travel time estimated by DTTC based on the detector occupancy is the same during most of the peak period (the vertical line of points in Figure 12), while the queue and the corresponding mean probe travel times first increase as a result of extreme congestion (where demand volume is higher than the capacity of the approach), and then decrease at the end of the peak period.

A conclusion drawn from this discussion is that the DTTC algorithm functions well if the queue length on a link does not significantly exceed the loop-detector setback for long periods of time. In other words, as long as the loop detector provides actual information on traffic conditions, DTTC provides accurate travel-time estimates. Except for the case when the queue length on a link significantly exceeds the setback of the loop detector for a long period, the range of differences between the probe and estimated travel times described in the previous two sections is actually not as great as the range of actual individual link travel times. These times may differ among themselves by the same range due to the vehicle arriving during a red or green light, with the variation reaching as much as 60 seconds. Assuming a signal cycle length of 120-150 seconds where the red time equals 50% of the cycle length, the difference in travel time between the vehicle that passed through the intersection just before the signal turned red and the travel time for the first vehicle which stopped on red may be up to 60 seconds.

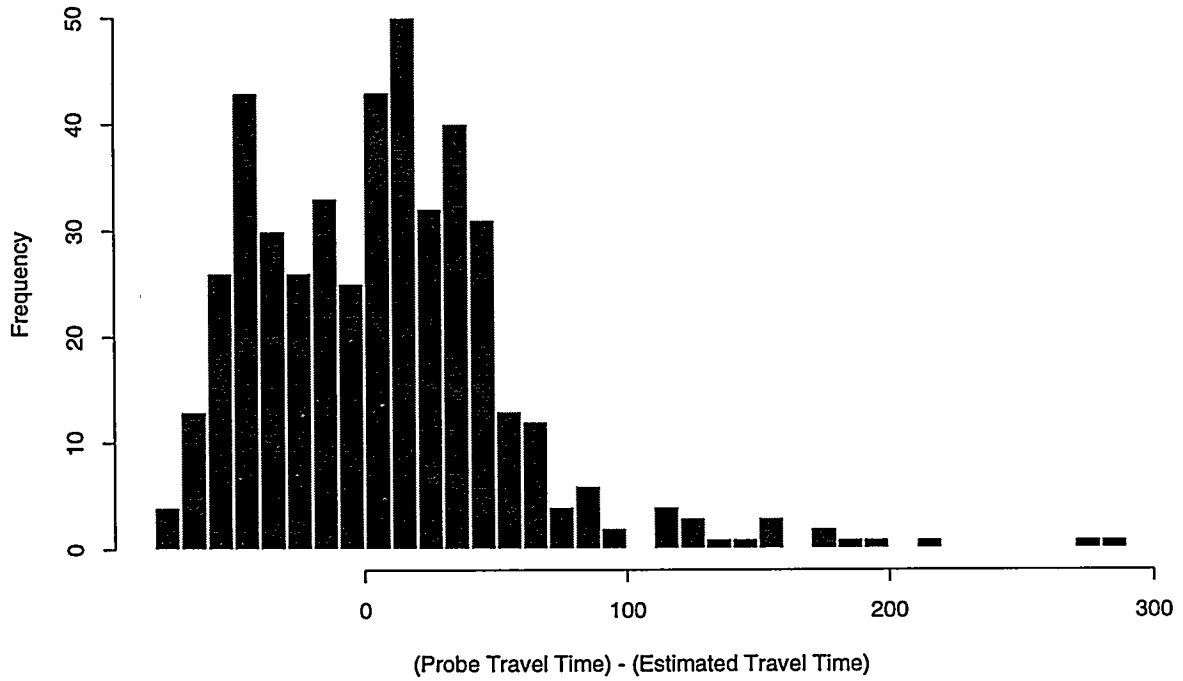
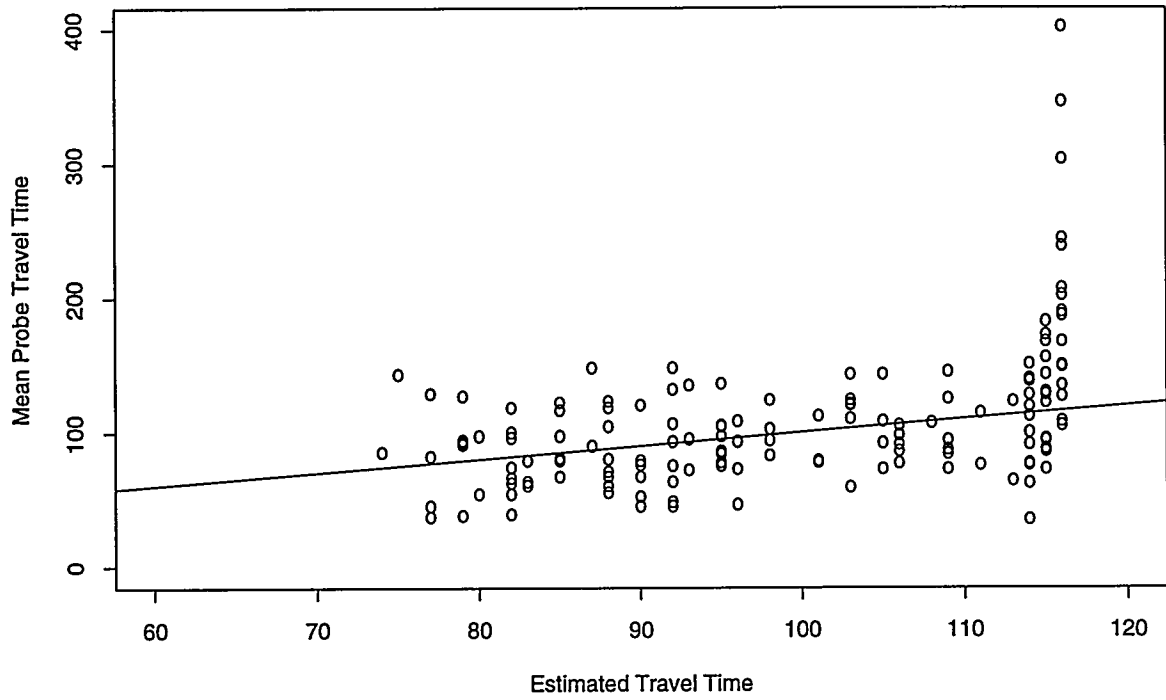

Figure 11: Difference between Probe and Estimated Travel Time: Link 7, Off-Peak, Detector Data Only

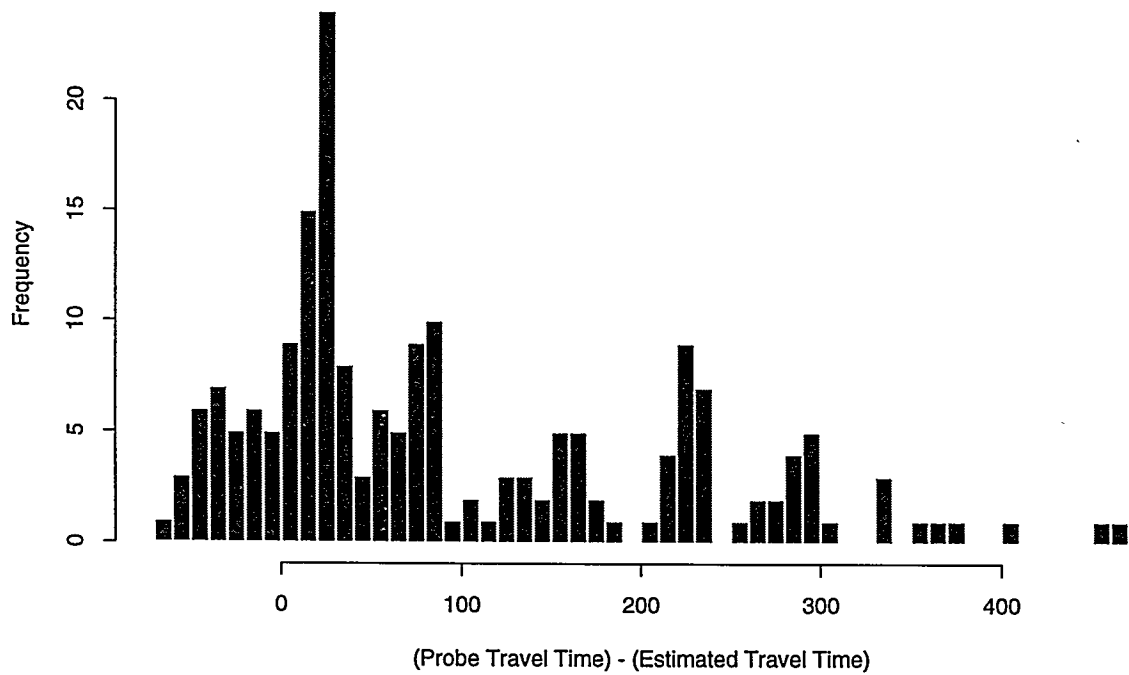
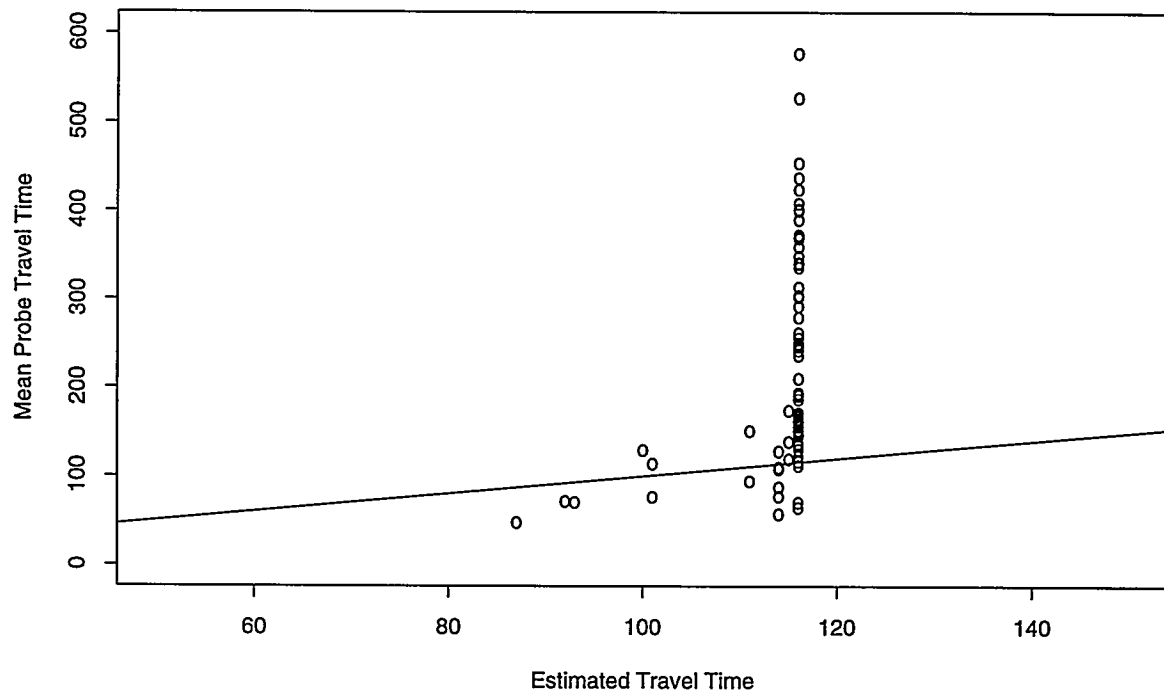

Figure 12: Difference between Probe and Estimated Travel Time: Link 7, Peak, Detector Data Only

8 Results for DTTC Fused with Probe Data

As before, these results are presented separately for the moderately-congested links, Links 1 and 11 and for the congested conditions of Link 7. While in the previous section all intervals with any number of reports were used for the analysis, in this and the following sections only those intervals with at least five reports per five-minute interval are analyzed. As noted earlier, this restriction is applied to facilitate comparisons among different deployment levels when probe data are used. Because not all possible five-minute intervals contain the minimum number (five) of probe reports to fulfill this requirement, the total number of intervals under consideration is decreased and is therefore substantially lower than in those cases using detector data only. The probe reported travel-time averages used for comparison with the DTTC travel-time estimates are always based on all probe reports available for the considered time interval. Therefore, while analysis using fused detector and probe-report data may examine fewer intervals, the probe report means to which they are compared always contain all probe reports for that time interval.

8.1 Moderately-Congested Case

8.1.1 Deployment Level 1

This discussion is based on Figures 13 and 14 for Link 1 and Figures 15 and 16 for Link 11. For Link 1 the difference between the probe and estimated travel times is typically less than 50 seconds, as in the case of DTTC without probe reports (Figures 7 and 9). The scattergrams for both cases (detector data only and fused probe and detector data) look similar. However, the histograms suggest that in some five-minute intervals the estimate derived without using probe data is better than that which includes probe data. For example, in the case using detector data only in the off-peak period, there are only four estimated travel times which differ from the probe travel time by more than 50 seconds (lower half of Figure 7), while there are seven such reports for the off-peak period using DTTC fused with probe data (lower half of Figure 13). While this observation is counterintuitive, it is not surprising. Consider the following example of the data for Link 1: the detector-based estimate is 82 seconds. For the same interval, there are five reports available (118, 63, 76, 72 and 56 seconds), and the mean travel time of these reports is 77 seconds. Assume that the one probe report that we randomly selected for the fusion process is the 118-second report. When this report is fused with the DTTC estimate of 82 seconds using weights appropriate for Link 1, we get a fused estimate of 112 seconds. This estimate is 35 seconds away from the probe mean travel time, compared to the DTTC estimate using detector data only which is only five seconds off the probe mean travel time. As this example shows, due to the random selection of probe reports for the fusion procedure, the addition of probe data to the DTTC estimate might not necessarily increase accuracy.

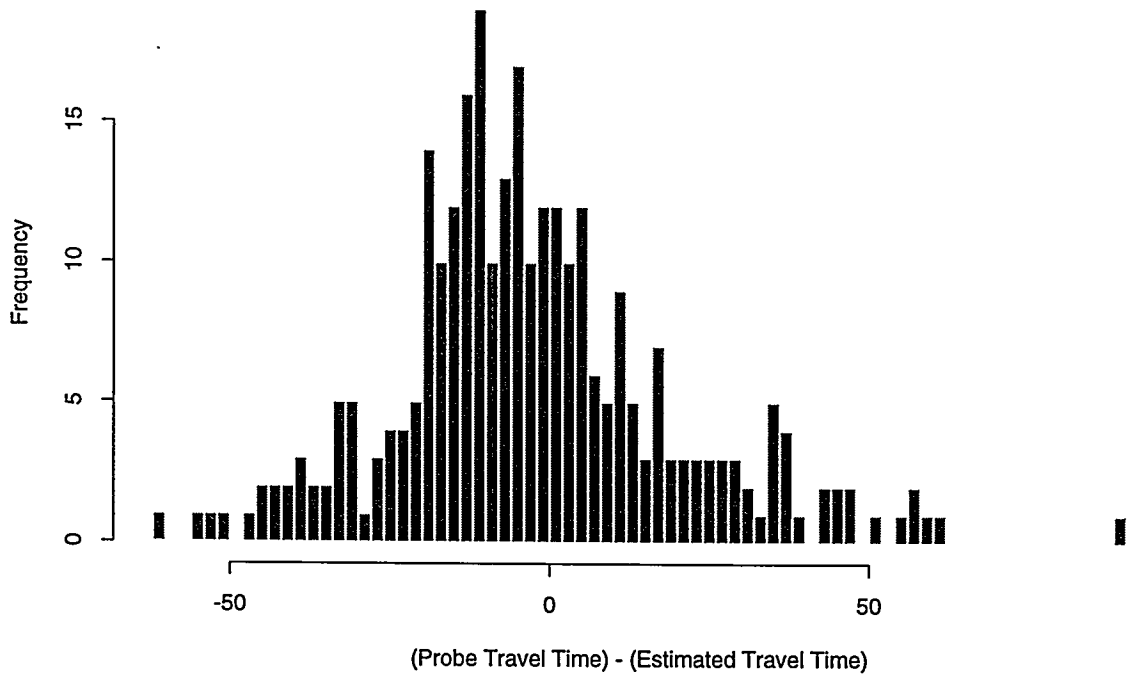
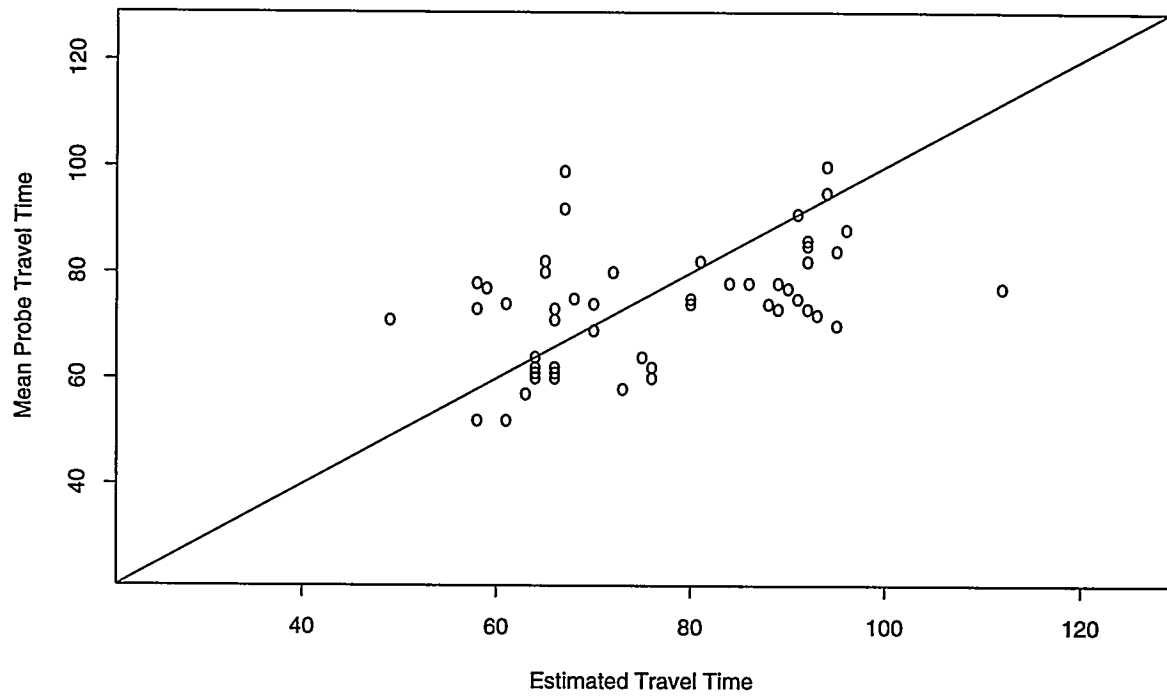

Figure 13: Difference between Probe and Estimated Travel Time: Link 1, Off-Peak, Deployment Level 1

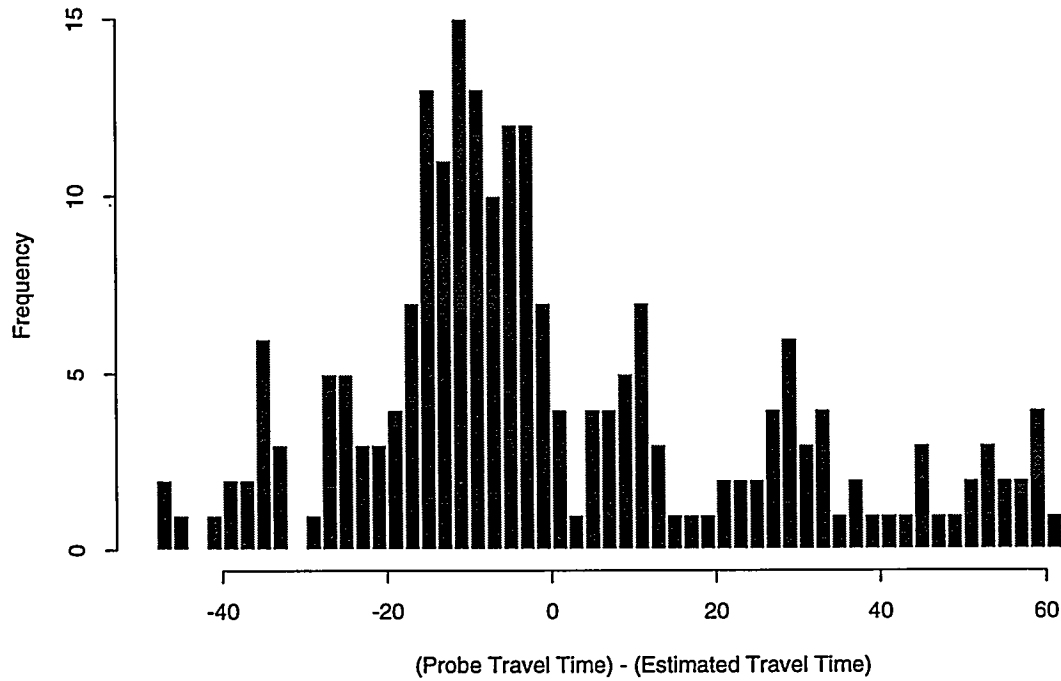
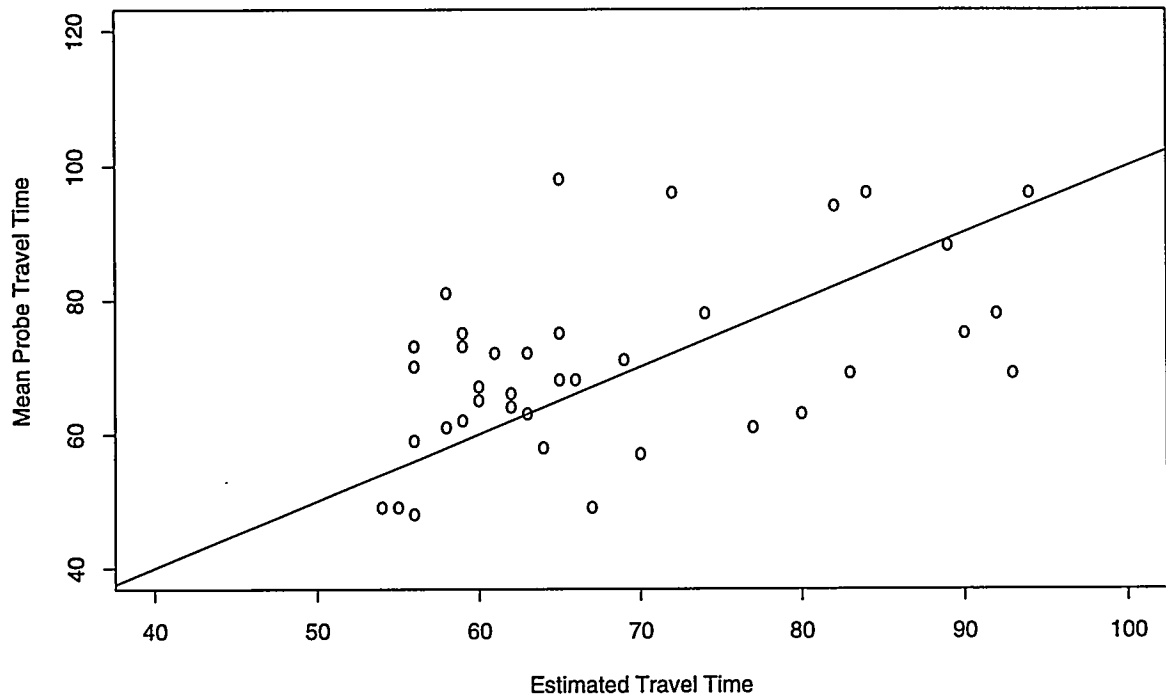

Figure 14: Difference between Probe and Estimated Travel Time: Link 1, Peak, Deployment Level 1

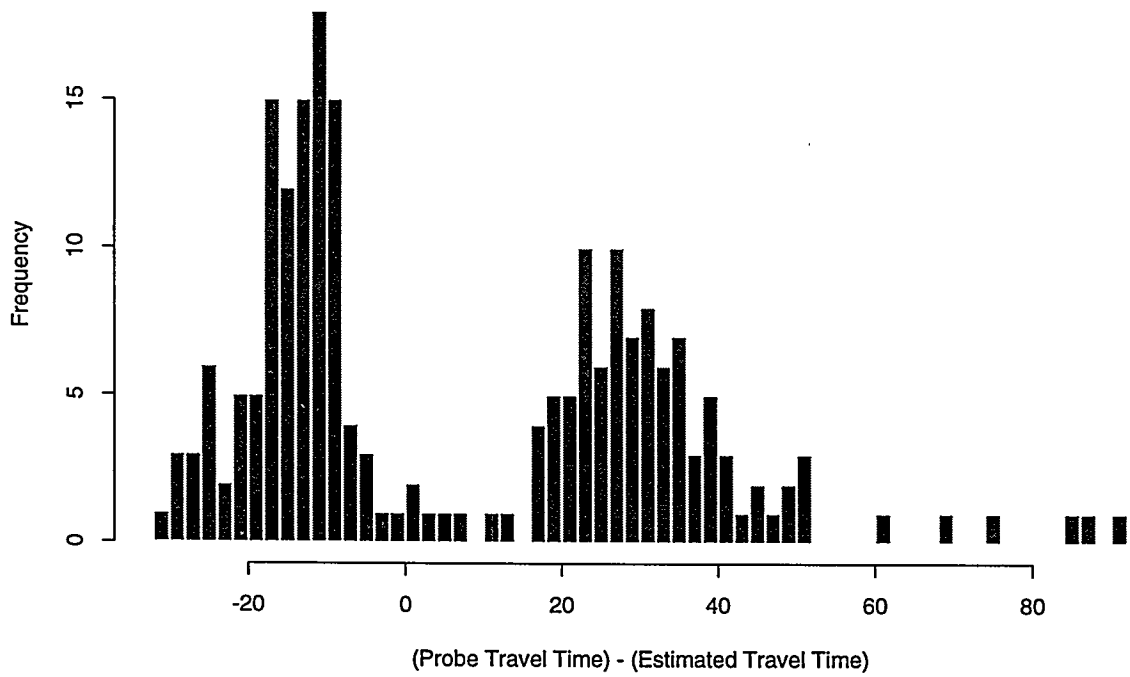
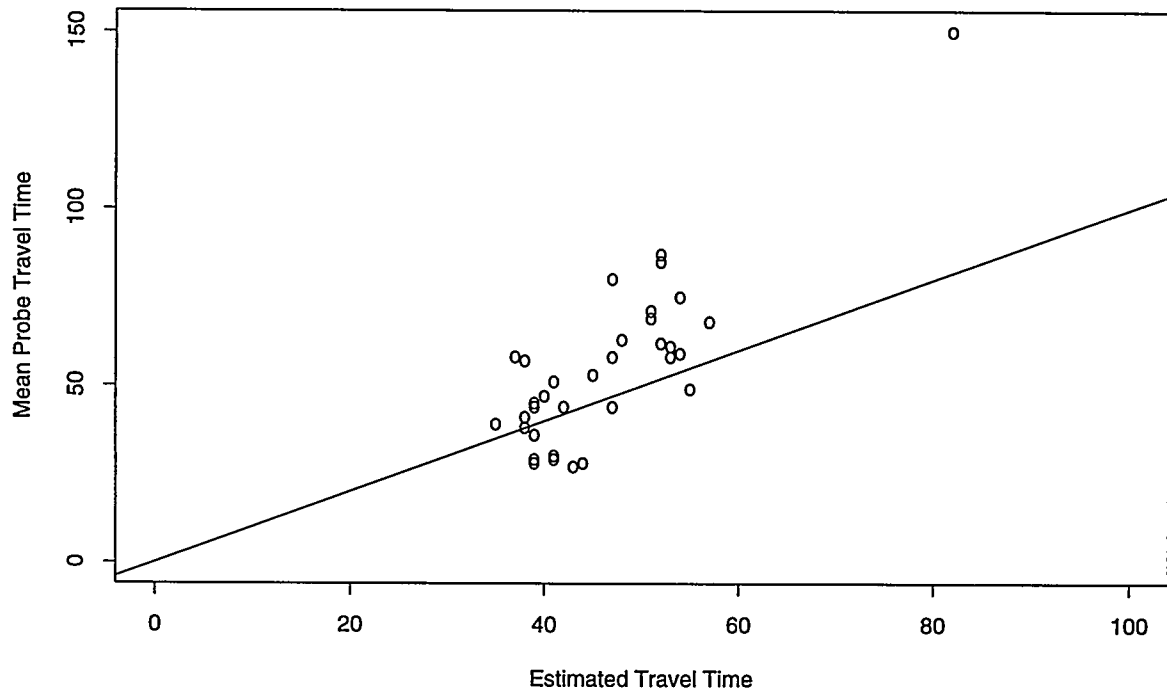

Figure 15: Difference between Probe and Estimated Travel Time: Link 11, Off-Peak, Deployment Level 1

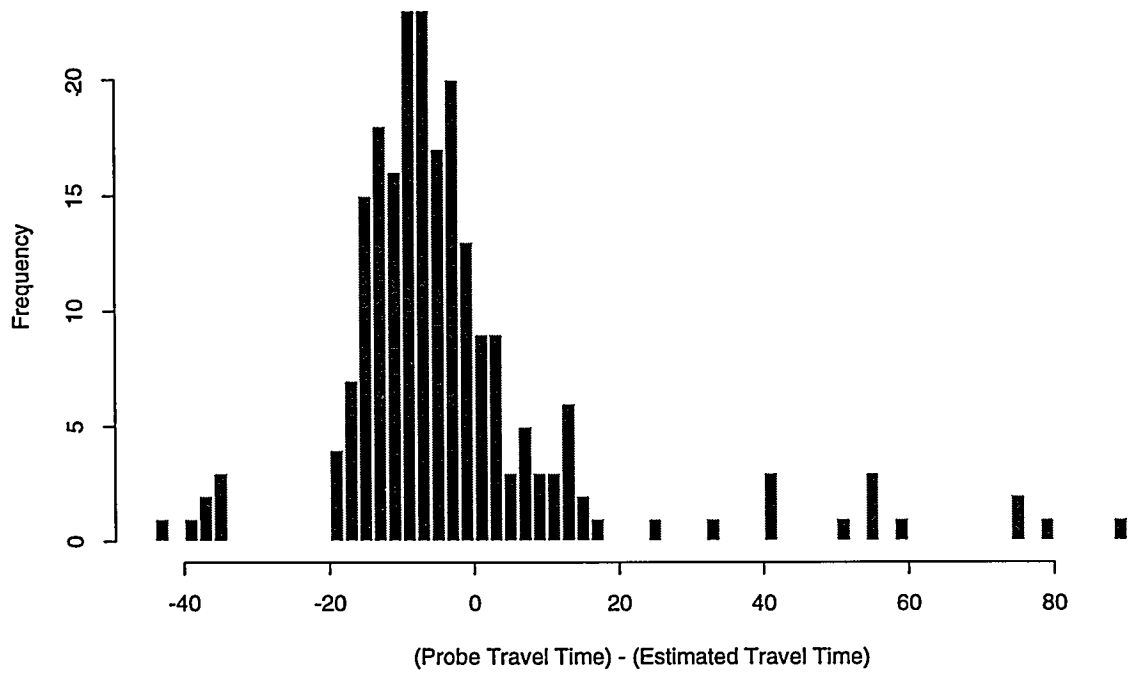
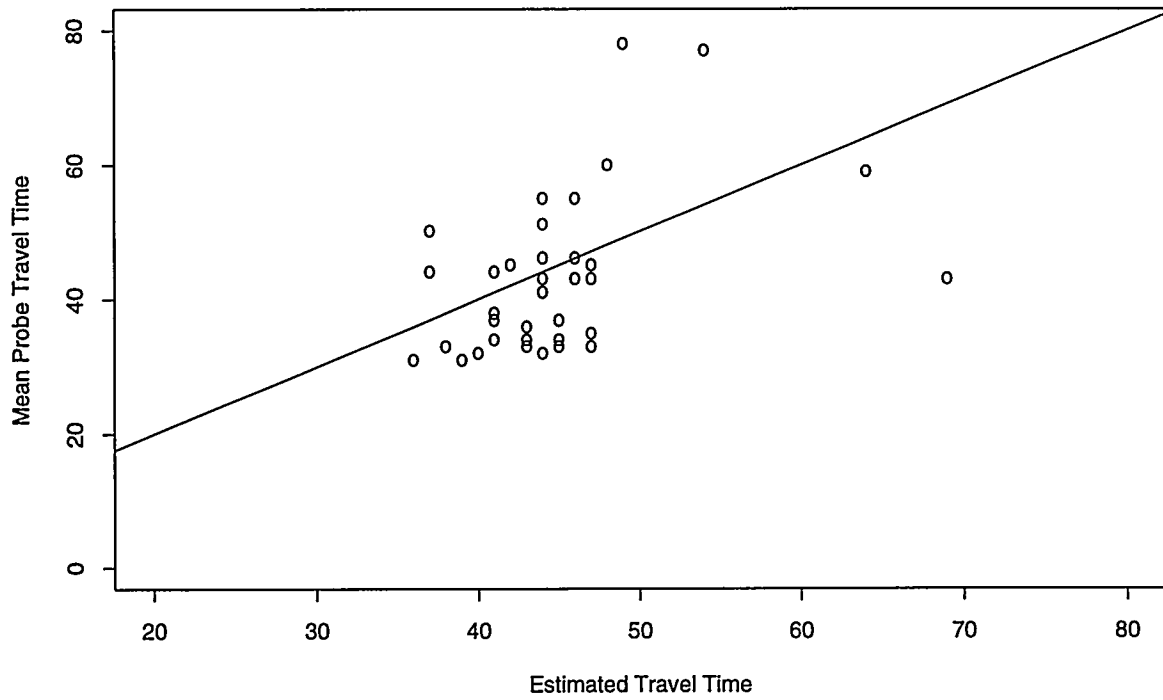

Figure 16: Difference between Probe and Estimated Travel Time: Link 11, Peak, Deployment Level 1

This discussion suggests that a single probe report may not be enough to improve the quality of the estimate: when only one report is used, it could be an outlier like the above 118-second report. Therefore, using more than one report would reduce the inaccuracies caused by the randomly-selected outliers. This observation is important, as the average number of probe reports per interval, even with the full deployment of 5000 probe vehicles traveling over the ADVANCE test area, was estimated to be 1.4 reports per 5-minute interval (see Hicks et al, 1992). However, it can be shown that fusing probe and detector data will, on average, yield more accurate reports. The above example is included merely to point out the possibility for inaccuracies; it is not to be taken as the predominant result of data fusion.

8.1.2 Deployment Level 3

Results for Deployment Level 3 are depicted in Figures 17, 18, 19 and 20. Several observations can be made based on these figures. First, the quality of the estimates is superior to those produced at Deployment Level 1. From the visual comparison of scattergrams in Figures 13, 14, 15 and 16 (Deployment Level 1) with 17, 18, 19 and 20 (Deployment Level 3), it can be seen that the plotted points are grouped more closely around the line of equal x and y values in the group of figures for the Deployment Level 3 case. The $x = y$ line itself represents the optimal relationship, where the mean probe and estimated travel times are identical. The second observation is that the difference between probe mean travel times and estimated travel times at this deployment level is generally less than 40 seconds (lower half of Figures 17, 18, 19 and 20); at lower deployment levels the difference often exceeds 50 seconds. The lower differences between travel time estimates and actual travel times indicate that as the number of probe reports increases, the travel-time estimates become more accurate. This observation also indicates that the increased correspondence is not compromised by whether the period being studied is peak or off-peak.

8.1.3 Deployment Level 5

While Figures 21, 22, 23, and 24 for Deployment Level 5 indicate a marginal increase in the quality of estimates in relation to probe reports, this marginal improvement is much smaller than the improvement between Deployment Levels 1 and 3. Where the upper range of the value of (probe travel time) - (estimated travel time) between Deployment Levels 1 and 3 dropped by 10 seconds to a level of about 40 seconds, the value of (probe travel time) - (estimated travel time) between Levels 3 and 5 only decreases by 5 seconds, to a level of about 35 seconds. These changes can be seen in Figures 21 and 22 for Link 1, and Figures 23 and 24 for Link 11. At this deployment level, an increase in deployment still appears to improve the overall estimate quality.

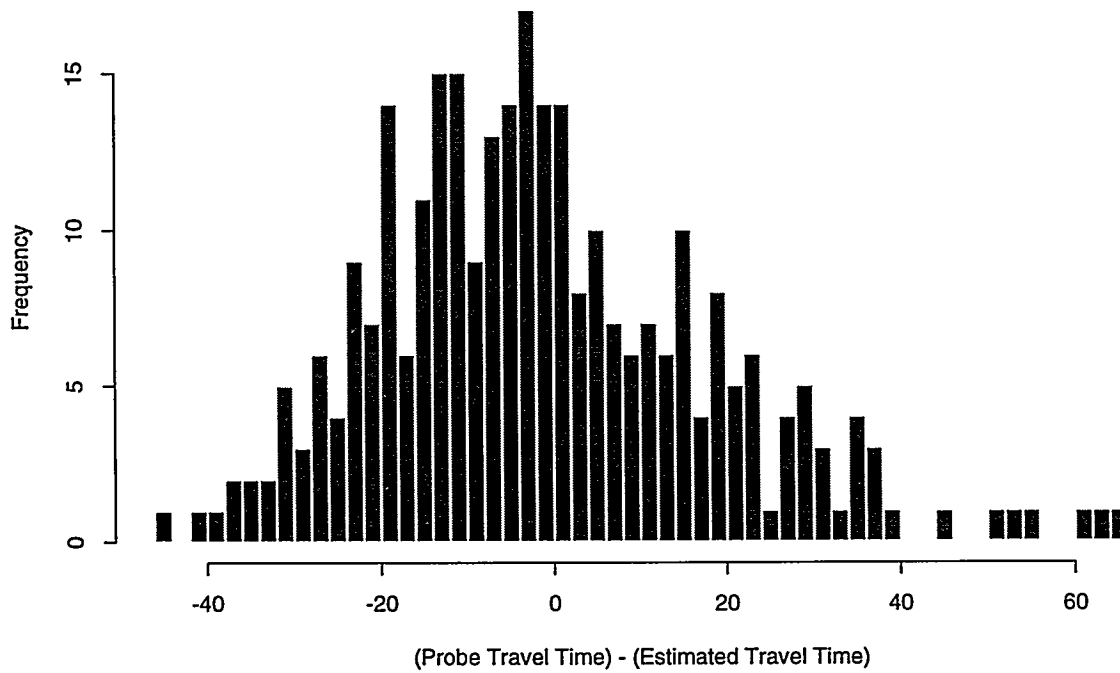
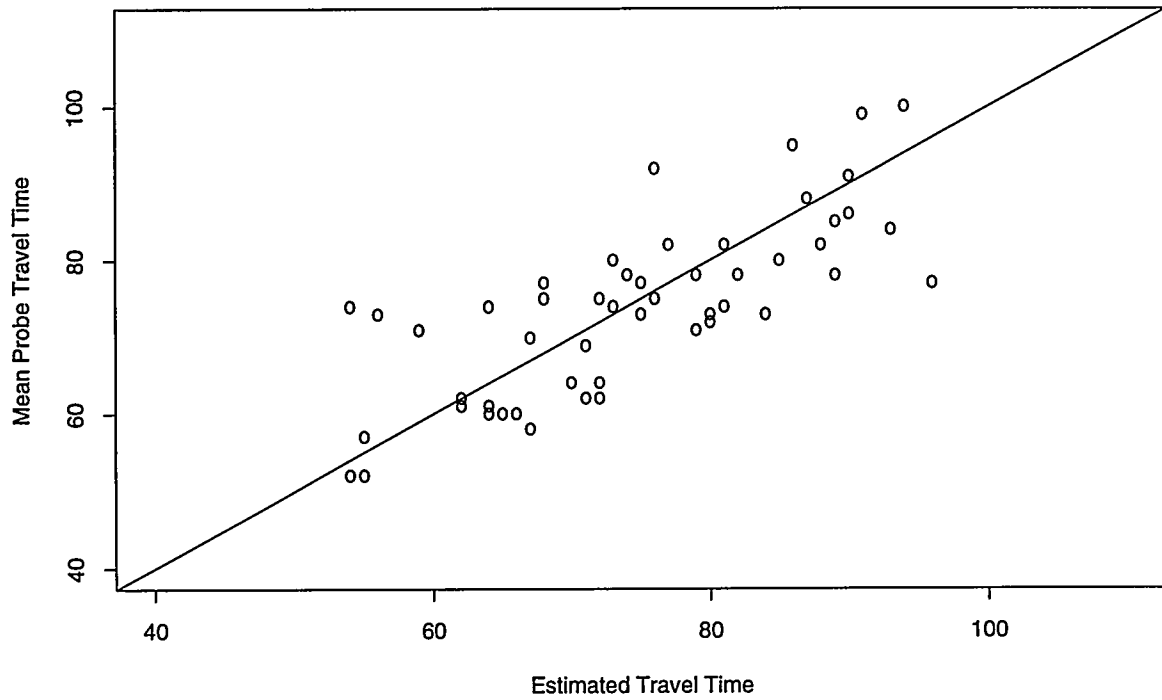

Figure 17: Difference between Probe and Estimated Travel Time: Link 1, Off-Peak, Deployment Level 3

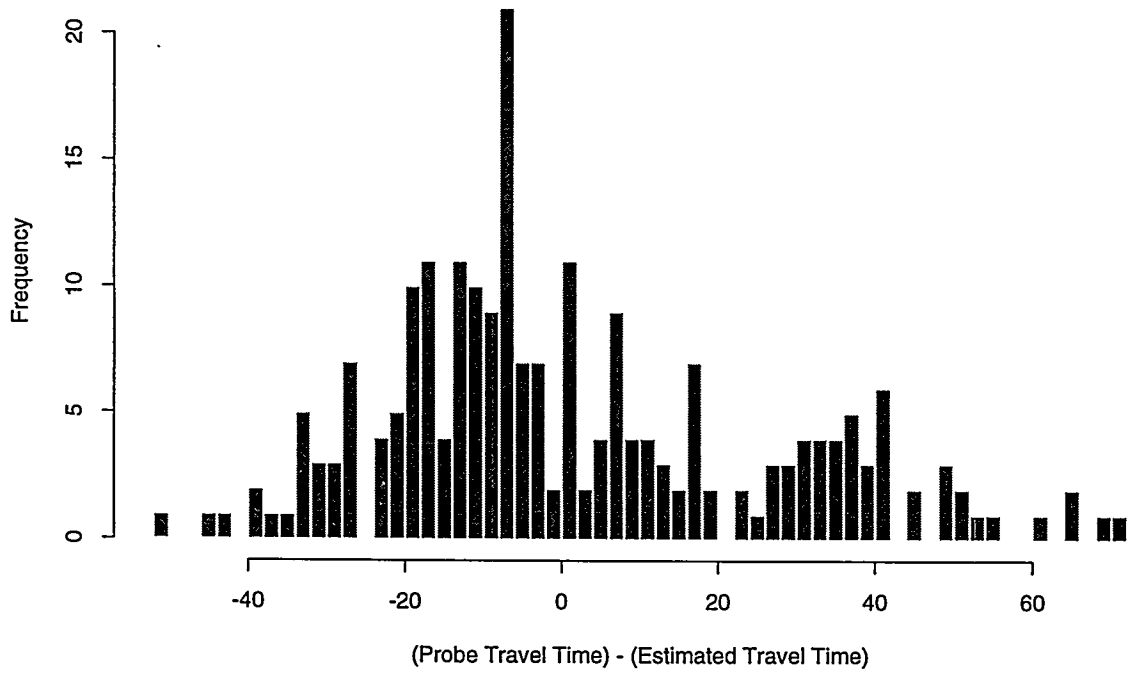
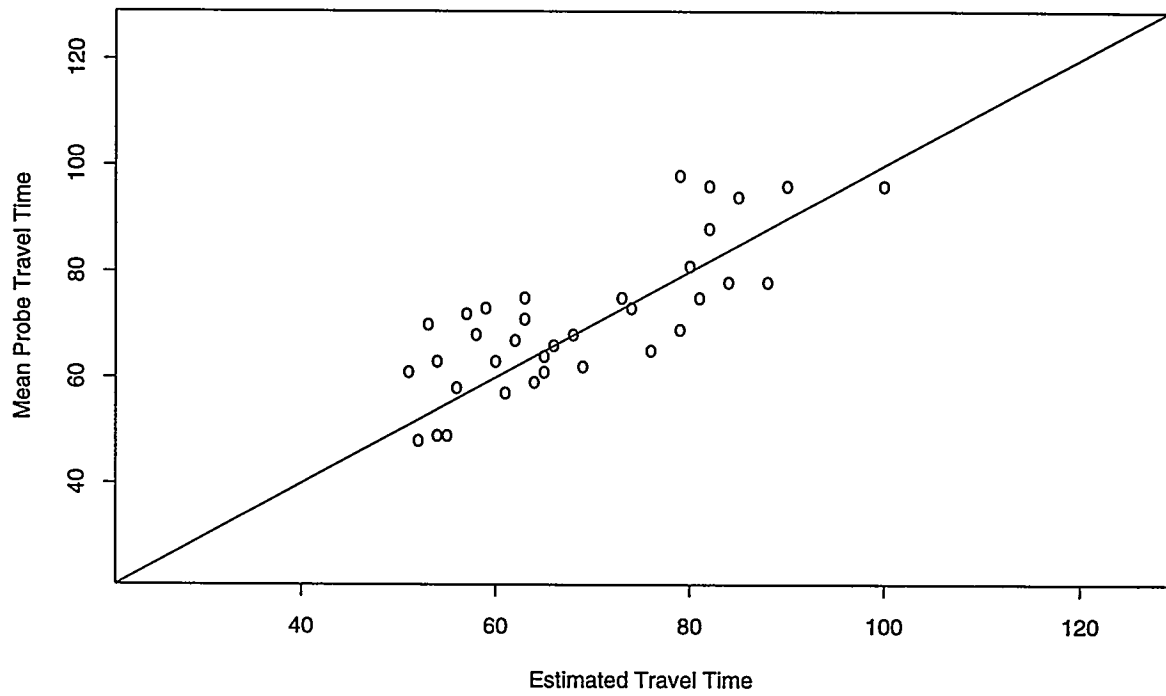

Figure 18: Difference between Probe and Estimated Travel Time: Link 1, Peak, Deployment Level 3

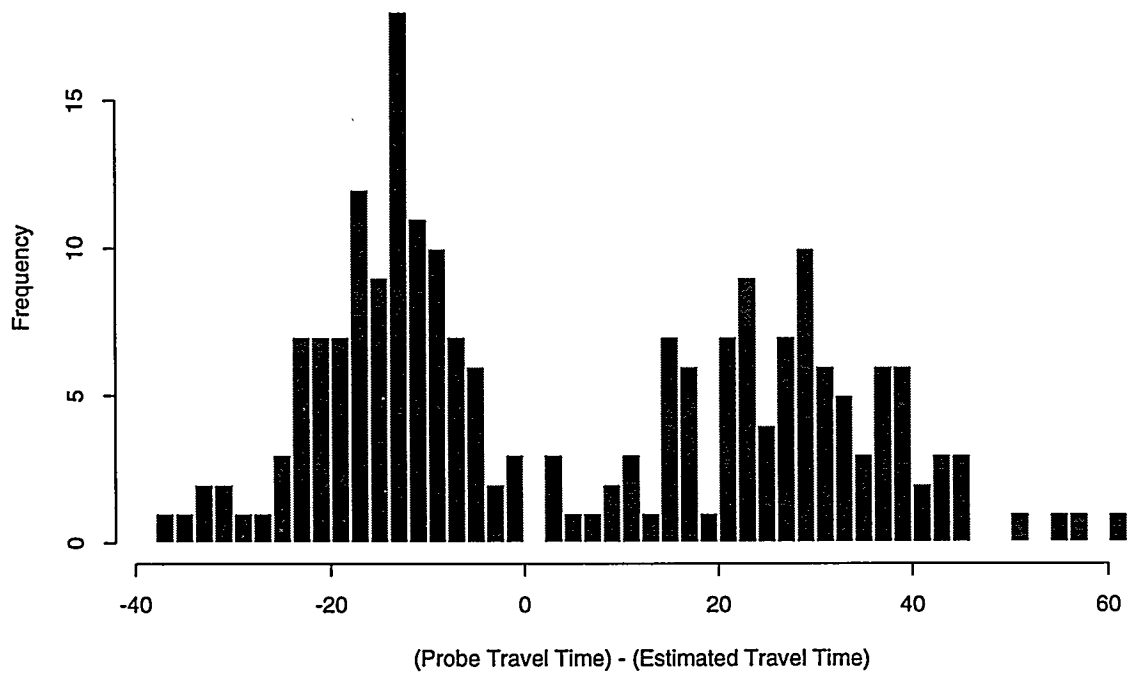
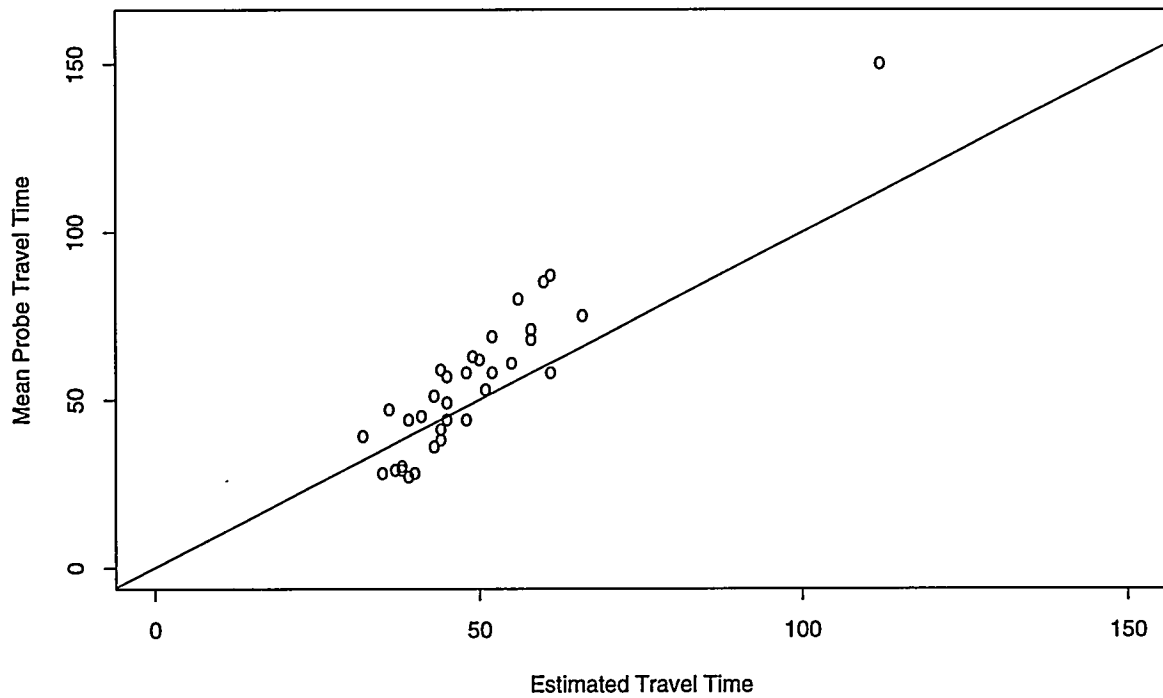

Figure 19: Difference between Probe and Estimated Travel Time: Link 11, Off-Peak, Deployment Level 3

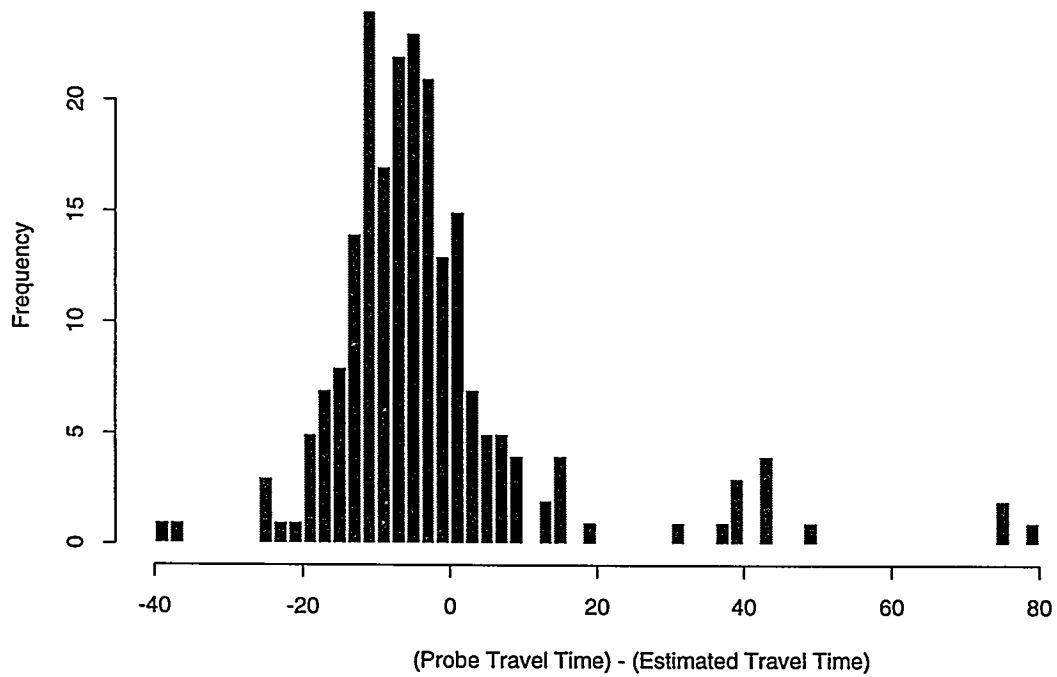
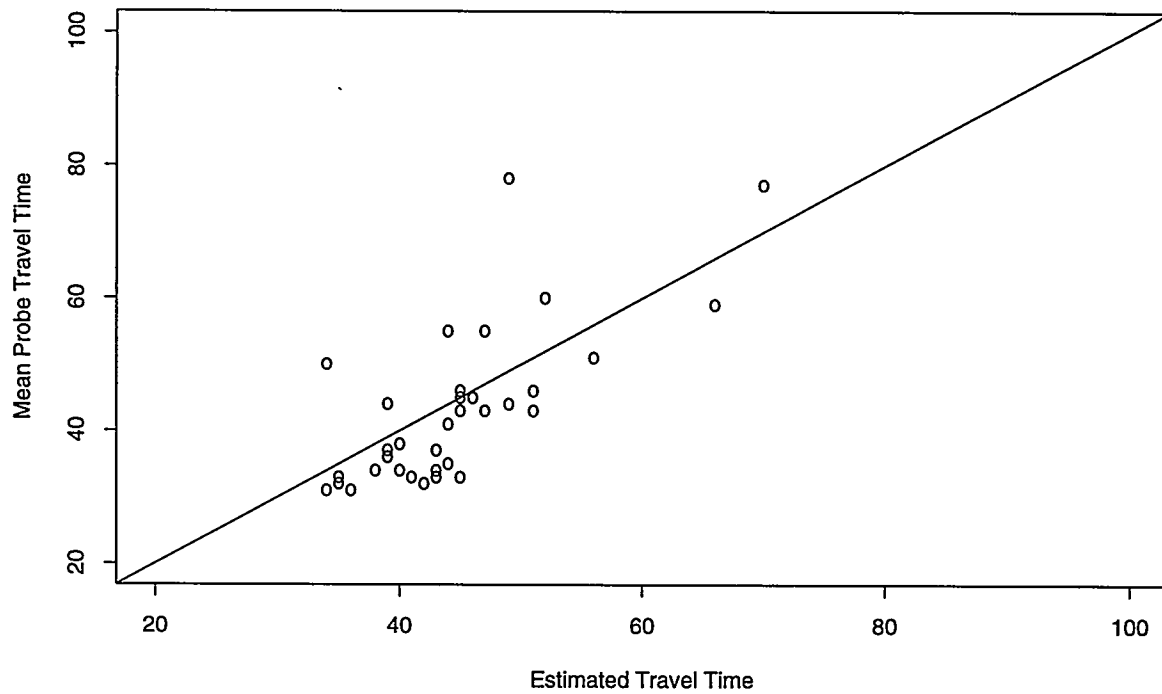

Figure 20: Difference between Probe and Estimated Travel Time: Link 11, Peak, Deployment Level 3

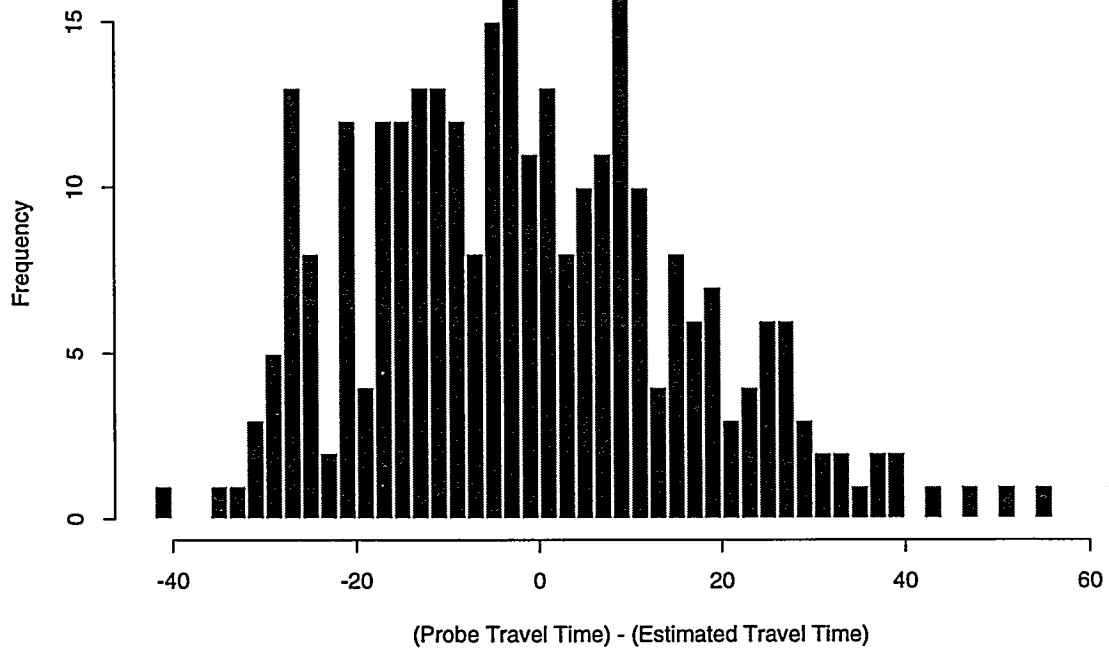
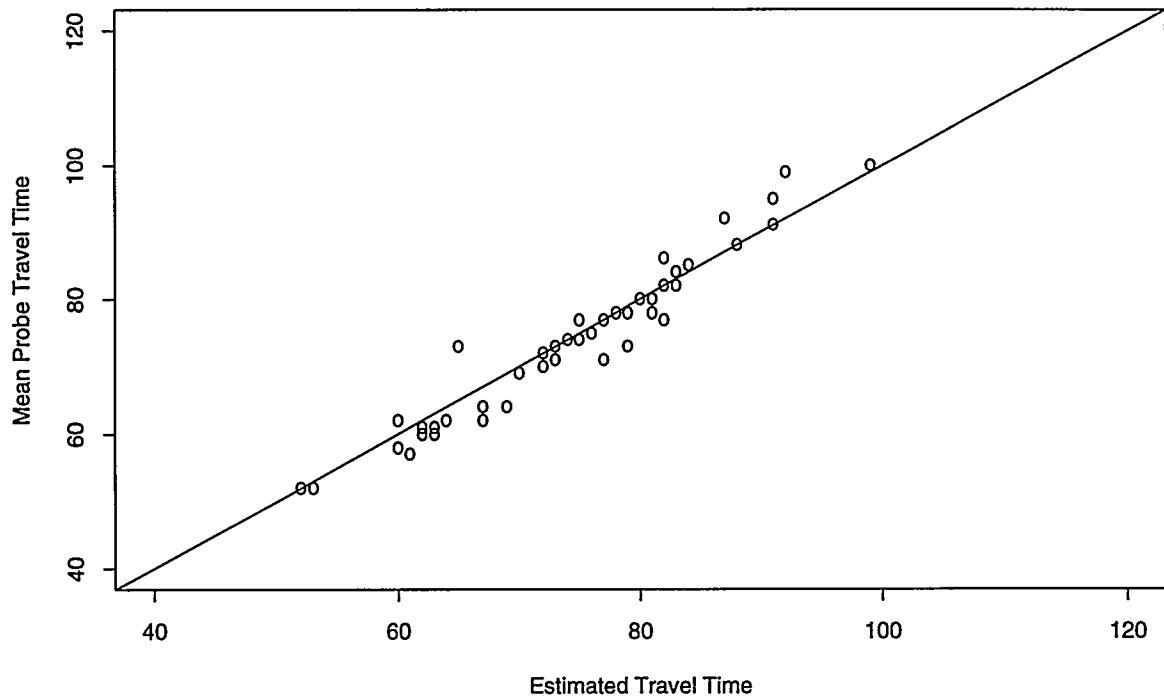

Figure 21: Difference between Probe and Estimated Travel Time: Link 1, Off-Peak, Deployment Level 5

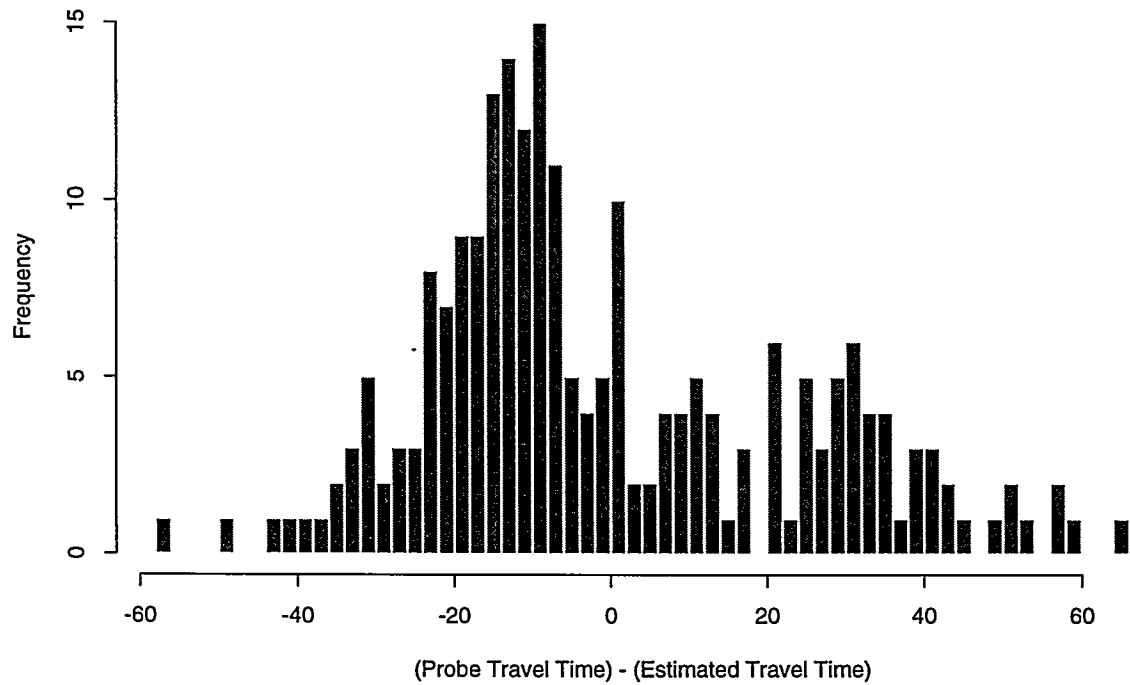
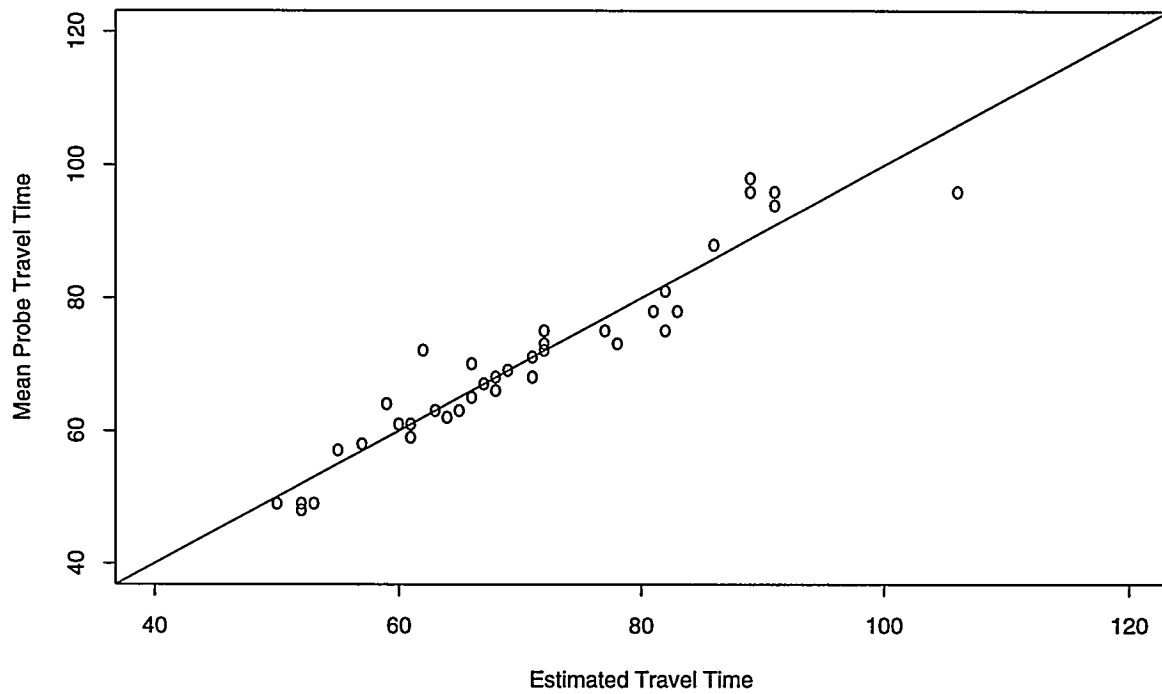

Figure 22: Difference between Probe and Estimated Travel Time: Link 1, Peak, Deployment Level 5

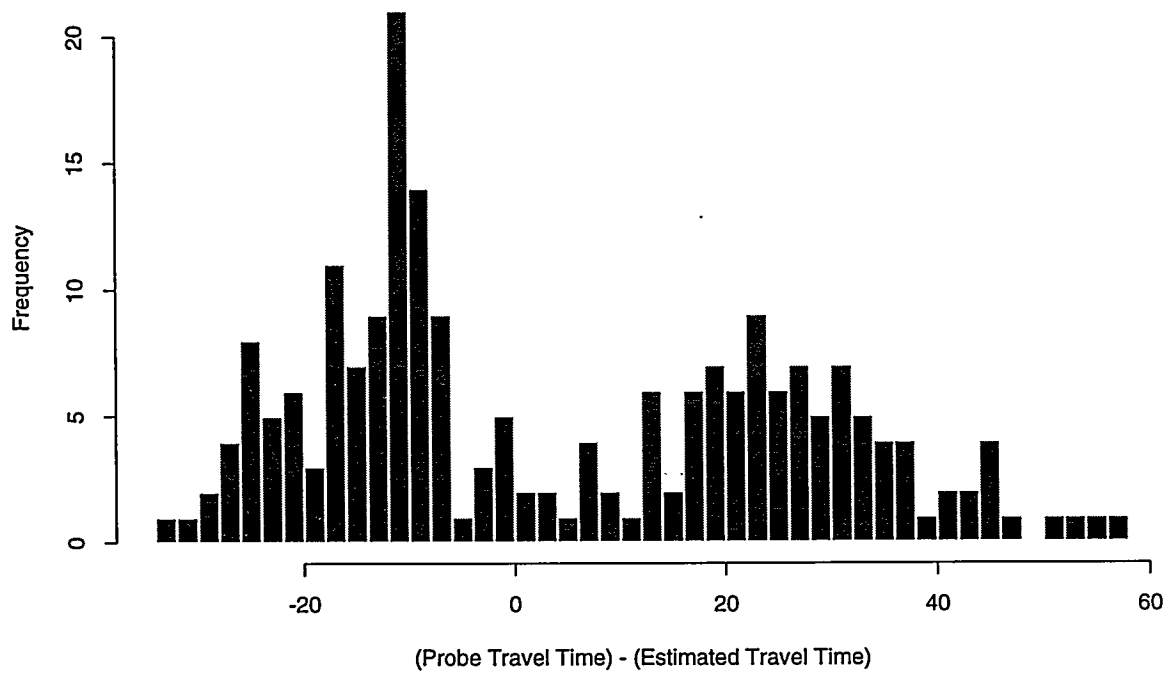
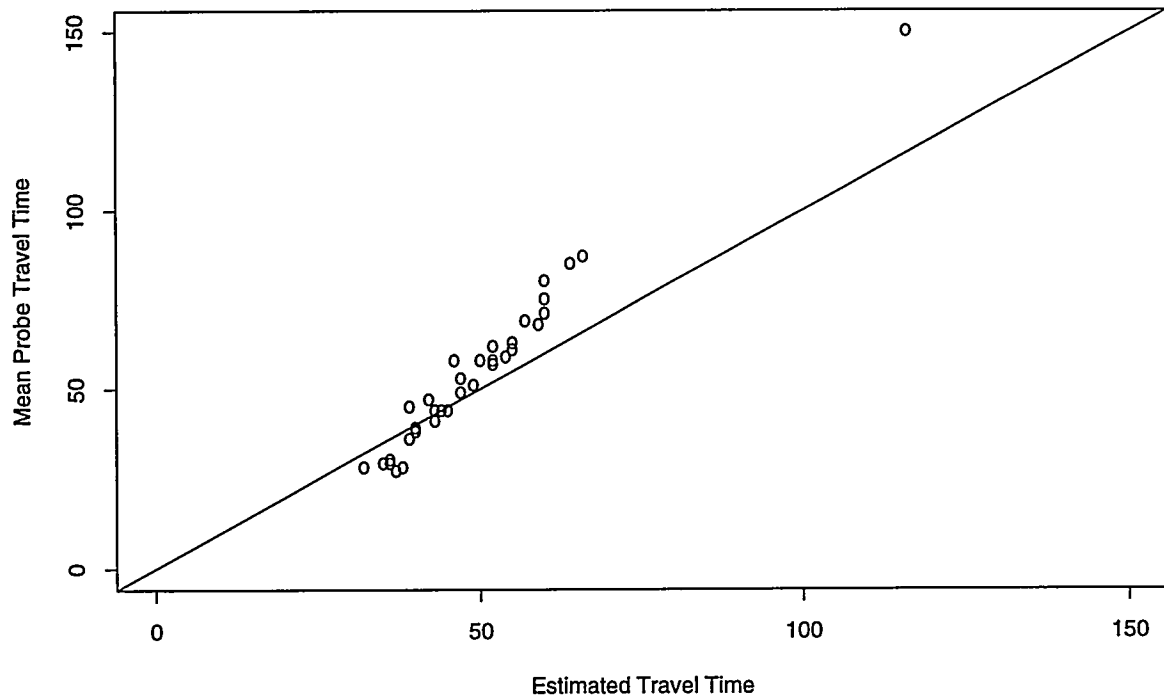

Figure 23: Difference between Probe and Estimated Travel Time: Link 11, Off-Peak, Deployment Level 5

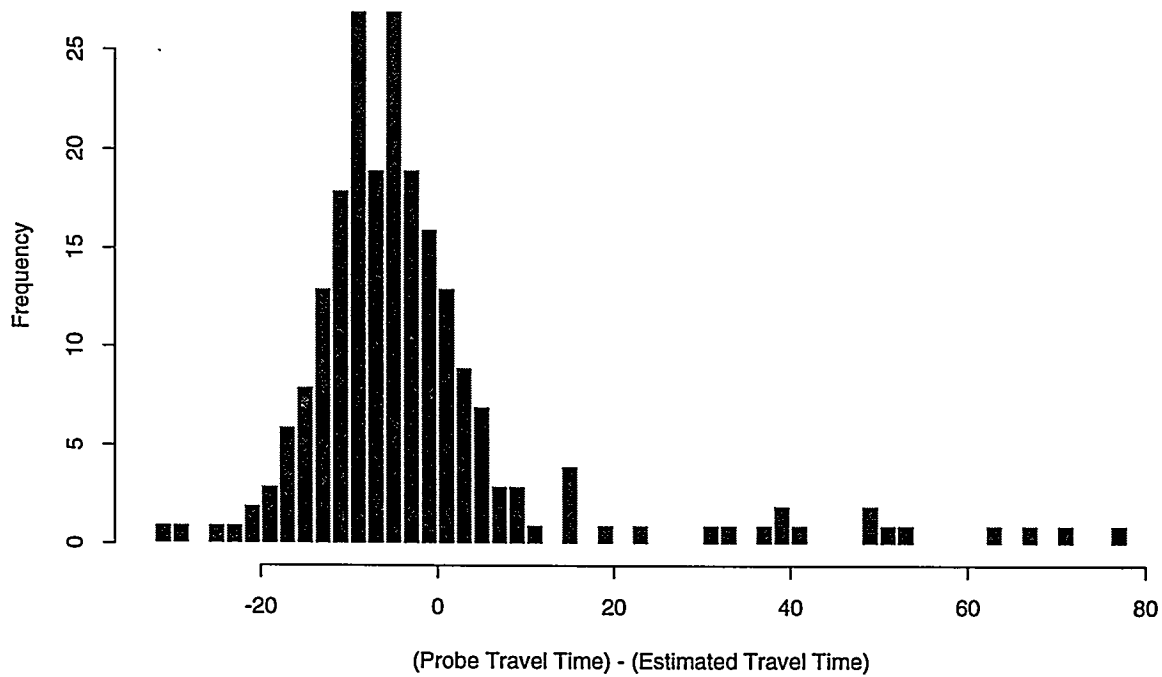
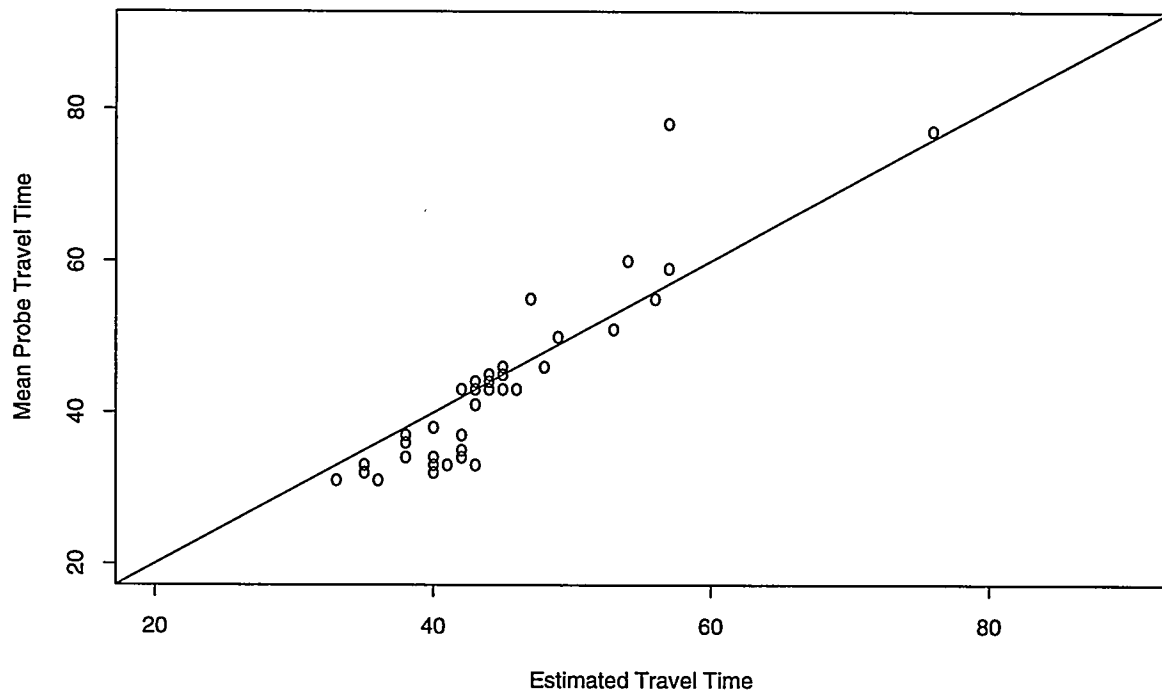

Figure 24: Difference between Probe and Estimated Travel Time: Link 11, Peak, Deployment Level 5

8.1.4 Overall Analysis of Various Deployment Levels

The decreased marginal improvement in estimate accuracy at Deployment Level 5 level could indicate that DTTC's travel-time predictive capabilities at higher deployment levels could reach a level where increased deployment would lead to incrementally small marginal improvements in estimate quality. This idea is illustrated in Figure 25. The overall difference between the average probe travel times and the DTTC estimates is decreasing as deployment levels go up. However, the slope is flattening out between Deployment Levels 3 and 5.

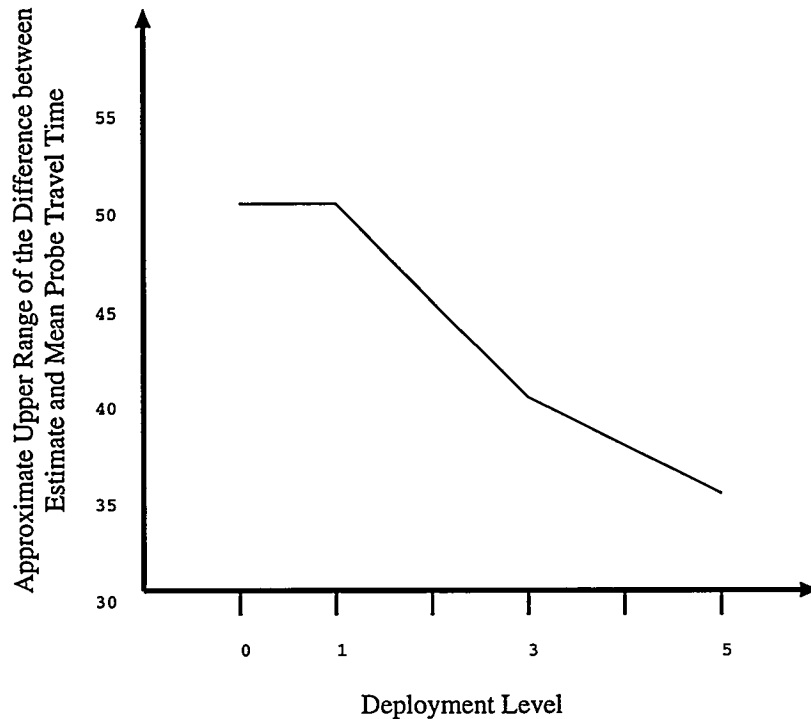

Figure 25: Changes in Estimate Quality by Deployment Level, Moderately Congested Case

Note: As our analysis covered only deployment levels 0, 1, 3 and 5 the average difference between probe and estimated travel times for deployment levels 2 and 4 can only be approximated by this curve.

The greatest marginal increase in travel-time estimate quality for the most moderate increase in deployment size is observed for Deployment Level 3. Because level 3 evidences such a good level of quality, Deployment Level 1 provides limited benefit for experimental purposes. In other words, because Deployment Level 3 results are so much more accurate than those at Level 1, there really is no purpose to proceeding with further examinations of Level 1 estimate results; their accuracy would not compare to Level 3 results. There is a marginal increase in estimate quality at Deployment Level 5.

The improvement in accuracy of travel-time estimates in moving from Level 3 to Level 5 is less than from moving from Level 1 to Level 3. The system designers must weigh the extra costs of moving to this level against desired levels of estimate accuracy.

A comparison of the overall quality of travel-time estimates based on detector data only and those estimates utilizing the fused data shows a significant improvement in estimate quality by adding the probe travel times at a deployment level of 3 or more probes per 5-minute interval. For example, the difference between the estimated and probe-reported travel time calculated using DTTC fused with probe data at Deployment Level 3 is rarely higher than 30 seconds for Links 1 and 11 in the off-peak (Figures 17 and 19) and 40 second in the peak period (Figures 18 and 20). The corresponding value for DTTC without DF is 50 seconds for these links (Figures 7, 9, 8, 10).

The analysis of the means and standard deviations of the differences between the travel time estimate and the mean probe travel time presented in Table 7 shows that the bias of the estimate (the mean of the differences) in most cases is less than 10 seconds. Compared to the absolute value of the travel time on Links 1 and 11 (shown on the y-axis of the scattergrams), this figure is rather low. It can also be observed that the bias for Link 1 is consistently negative, and that for Link 11 is positive. These phenomena are most likely due to the fact that the DTTC model was calibrated using very small data samples (a sufficiently large data sample was not available at that time). The bias drops significantly with the increased deployment level; even at Level 3, the absolute value of the bias drops to 0.6 and 5.6, for Links 1 and 11, respectively.

Table 7: Summary Characteristics of Differences Between Travel-Time Estimates (Moderately-Congested Case) and Mean Probe Travel Times.

| Deployment Level | Link | Mean | Variance | Standard Deviation |
|------------------|------|---------|----------|--------------------|
| 0 | 1 | -7.922 | 478.1087 | 21.866 |
| 0 | 11 | 13.42 | 794.916 | 28.194 |
| 1 | 1 | -2.072 | 491.212 | 22.163 |
| 1 | 11 | 8.071 | 672.9087 | 25.940 |
| 3 | 1 | -0.6048 | 373.8674 | 19.336 |
| 3 | 11 | 5.595 | 540.7971 | 23.255 |
| 5 | 1 | -0.6151 | 322.41 | 17.956 |
| 5 | 11 | 5.057 | 495.3077 | 22.256 |

8.2 Congested Case

8.2.1 Deployment Level 1

Several observations can be made about Figures 26 and 27, on the following pages. For Link 7 in the peak period (see the scattergram in Figure 27) the number of observations

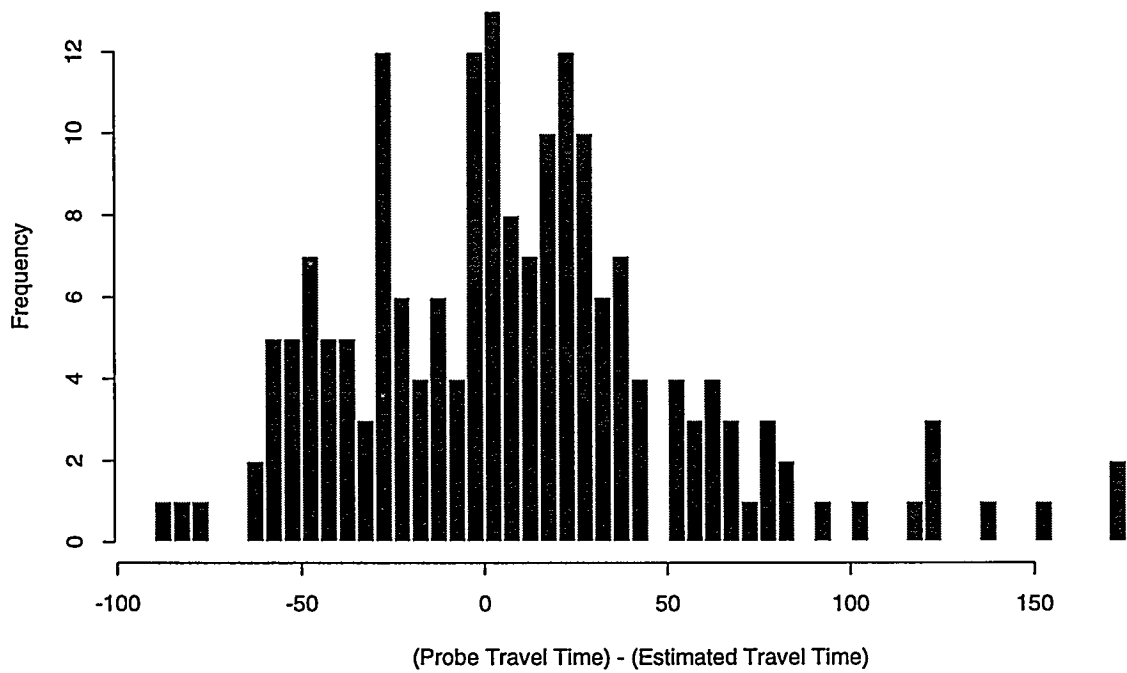
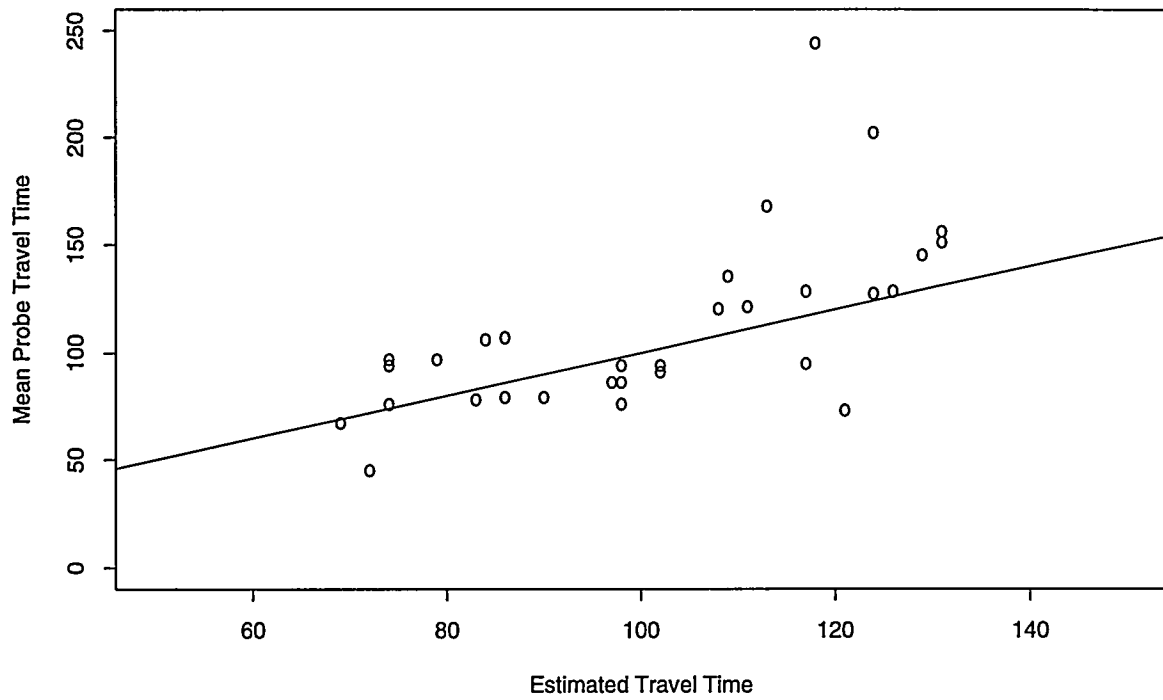

Figure 26: Difference between Probe and Estimated Travel Time: Link 7, Off-Peak, Deployment Level 1

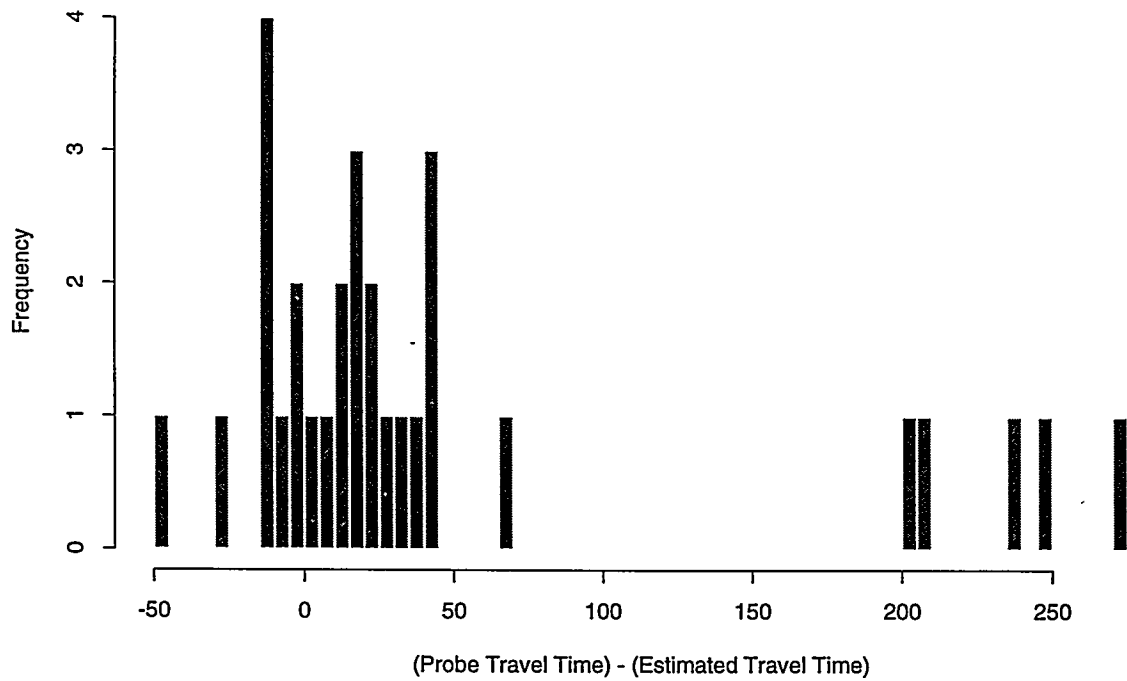
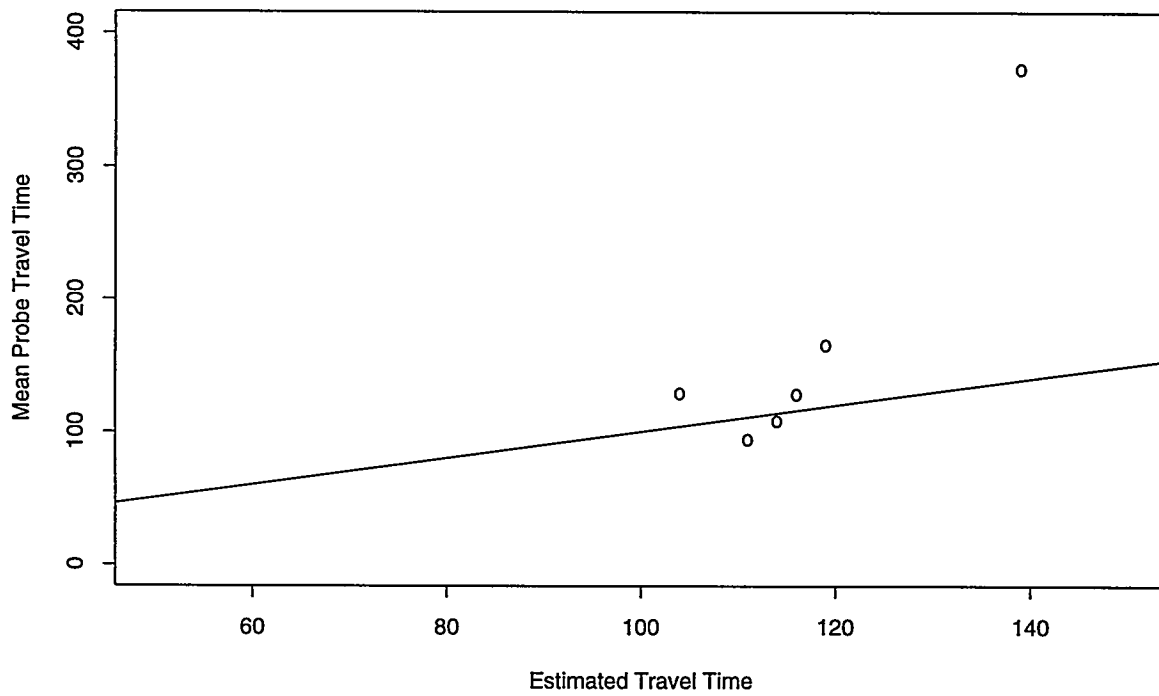

Figure 27: Difference between Probe and Estimated Travel Time: Link 7, Peak, Deployment Level 1

is too low to make a good judgement, but out of the available six intervals five show a difference between probe and estimated travel time within 30 seconds. The maximum difference between probe travel times and estimated travel times (off-peak) dropped from almost 300 seconds for DTTC only (Figure 11) to about 150 seconds for probes (at Deployment Level 1) and detectors (Figure 26). A similar improvement can be seen for peak estimations: the maximum difference between probe data and estimates dropped from over 400 seconds (Figure 12) to about 250 seconds (Figure 27).

These comments indicate that in the congested case, even one report per interval is useful in increasing the quality of the DTTC estimate.

8.2.2 Deployment Level 3

In similar fashion to Deployment Level 1, the introduction of probe data at Deployment Level 3 increases the overall quality of the travel-time estimation process. This may be seen in Figures 28 and 29. As for Deployment Level 1, the maximum difference between probe and estimated travel times also dropped here, to about 100 seconds during the off-peak period, (see the scattergram in Figure 26). This is less true for the peak period, for which a small amount of data is available. No immediate conclusion can be drawn about the peak period (there are too few observations), but the off-peak period evidences significant improvements in the travel-time estimates between DTTC only and DTTC fused with probe reports.

8.2.3 Deployment Level 5

This discussion refers to Figure 30 (while Figure 31 presents results for the same case for peak period, the number of observations is much lower than in the off-peak period and may provide only supporting evidence for the conclusions drawn below). As with the previous sections, the upper range of the difference between estimated and probe-reported travel times again dropped as the deployment of probes increased.

Comparing the scattergrams in Figures 28 (Deployment Level 3) and 30 (Deployment Level 5) shows the points to be moving closer to the line $x = y$; comparing the frequency distributions in the same two figures shows the differences between the probe travel time and the estimated travel time to be lower and more concentrated around zero at Deployment Level 5

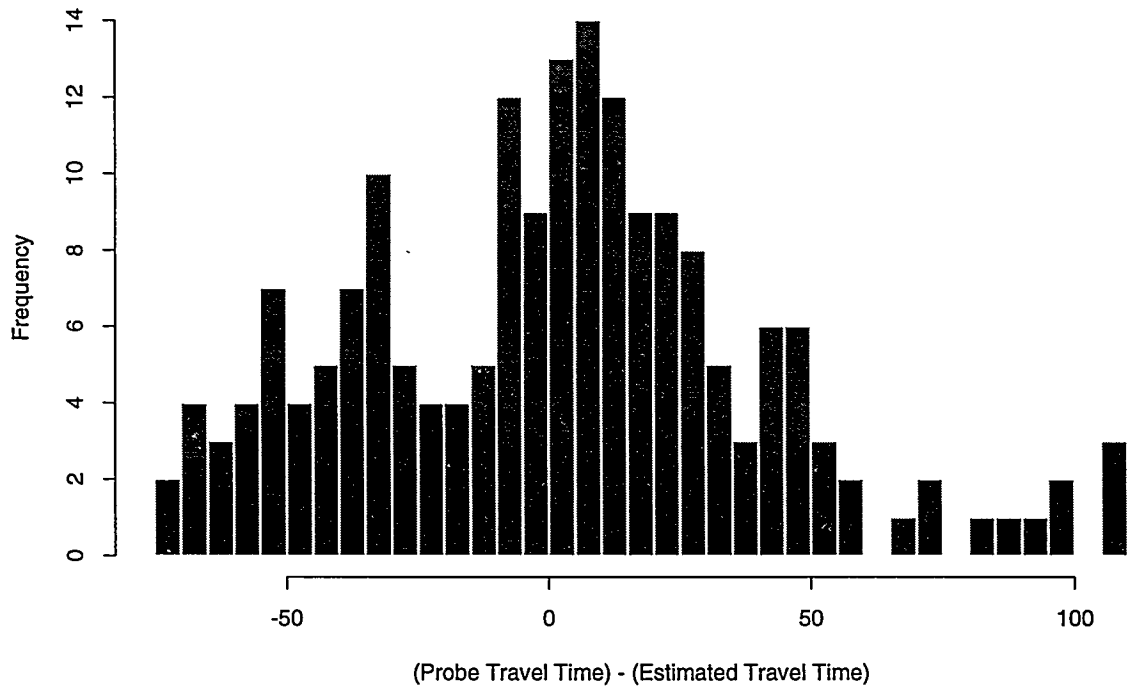
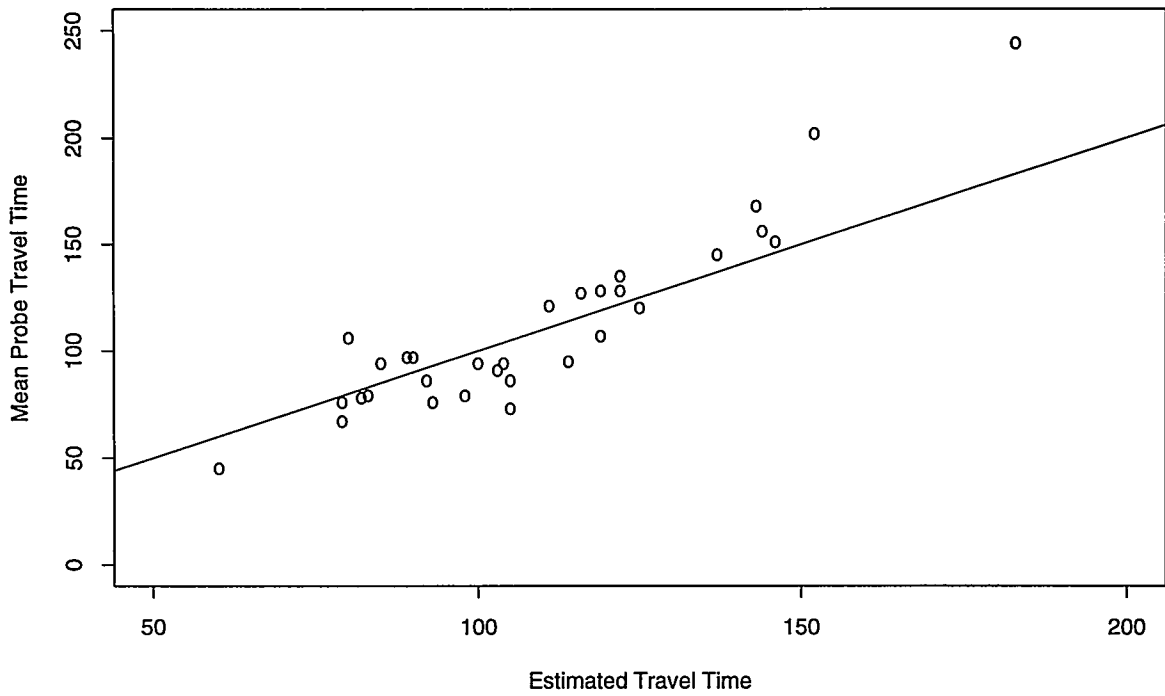

Figure 28: Difference between Probe and Estimated Travel Time: Link 7, Off-Peak, Deployment Level 3

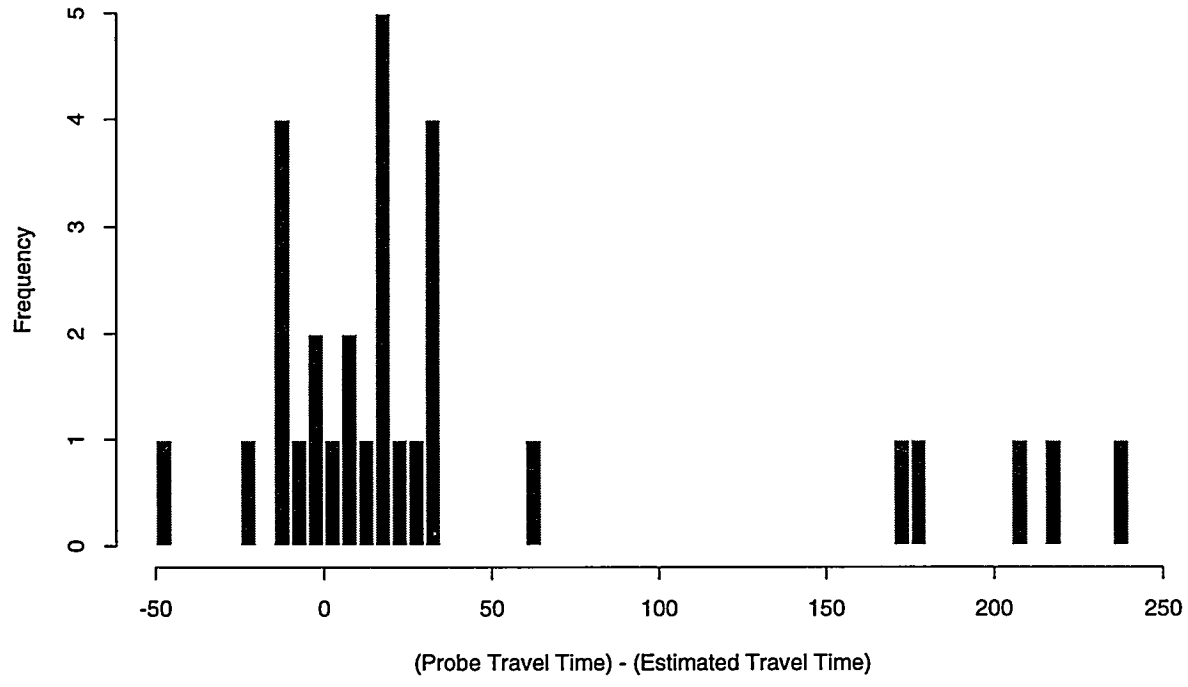
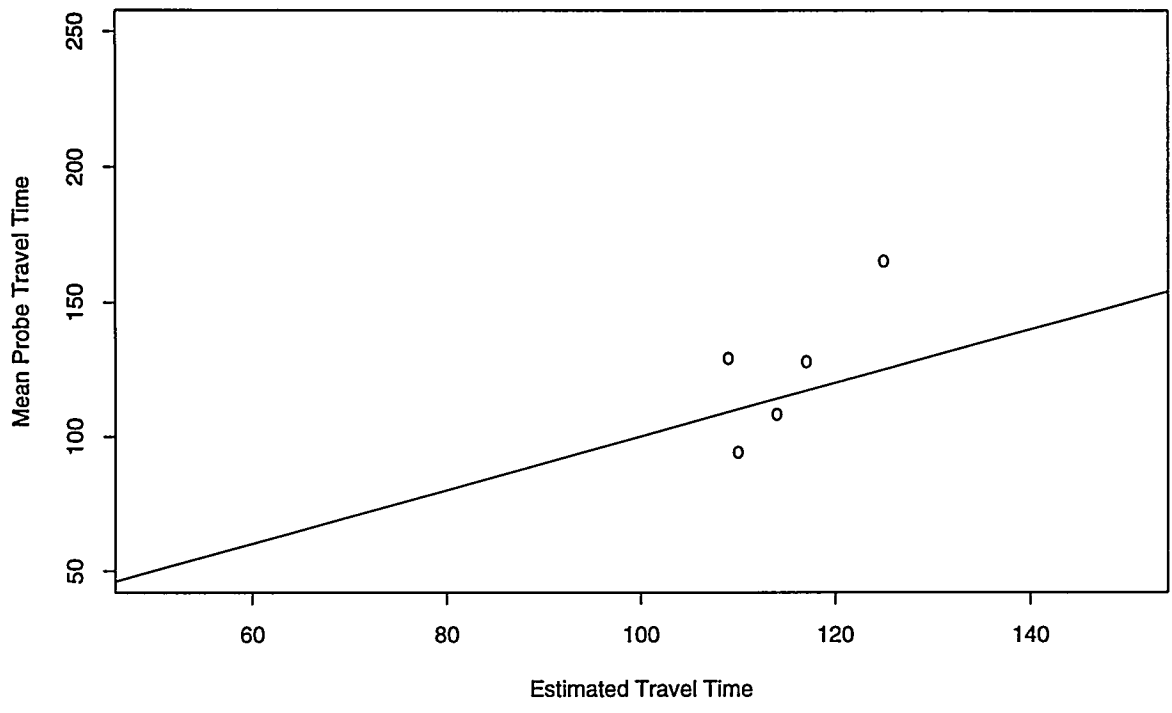

Figure 29: Difference between Probe and Estimated Travel Time: Link 7, Peak, Deployment Level 3

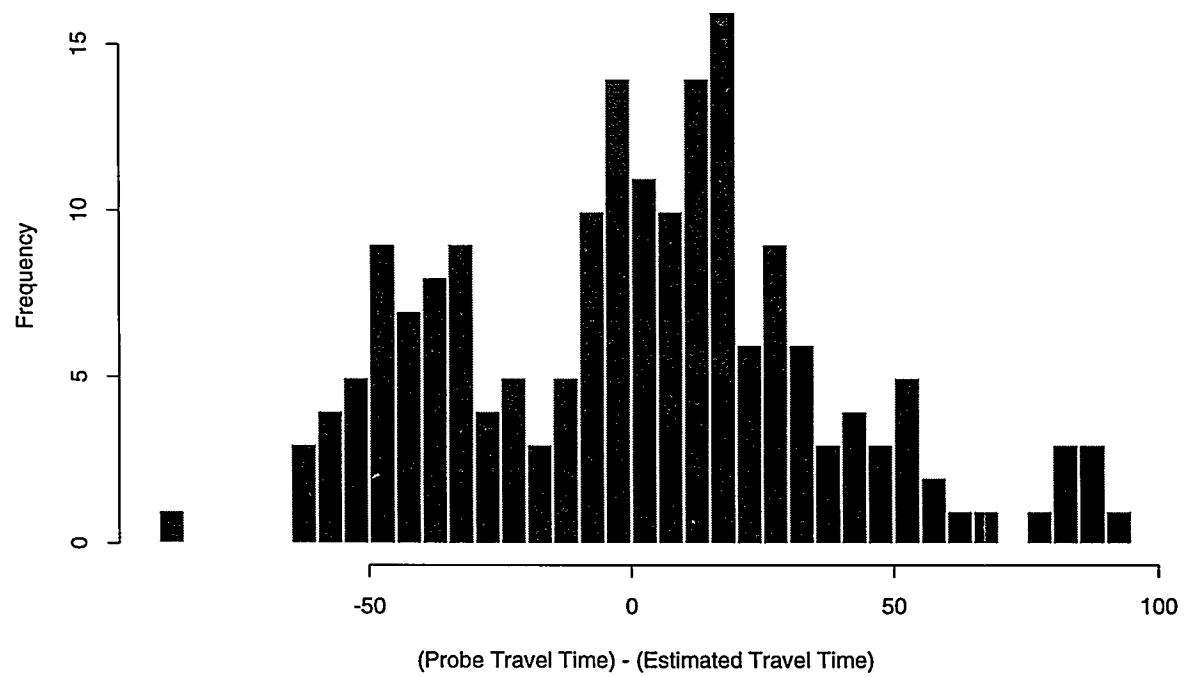
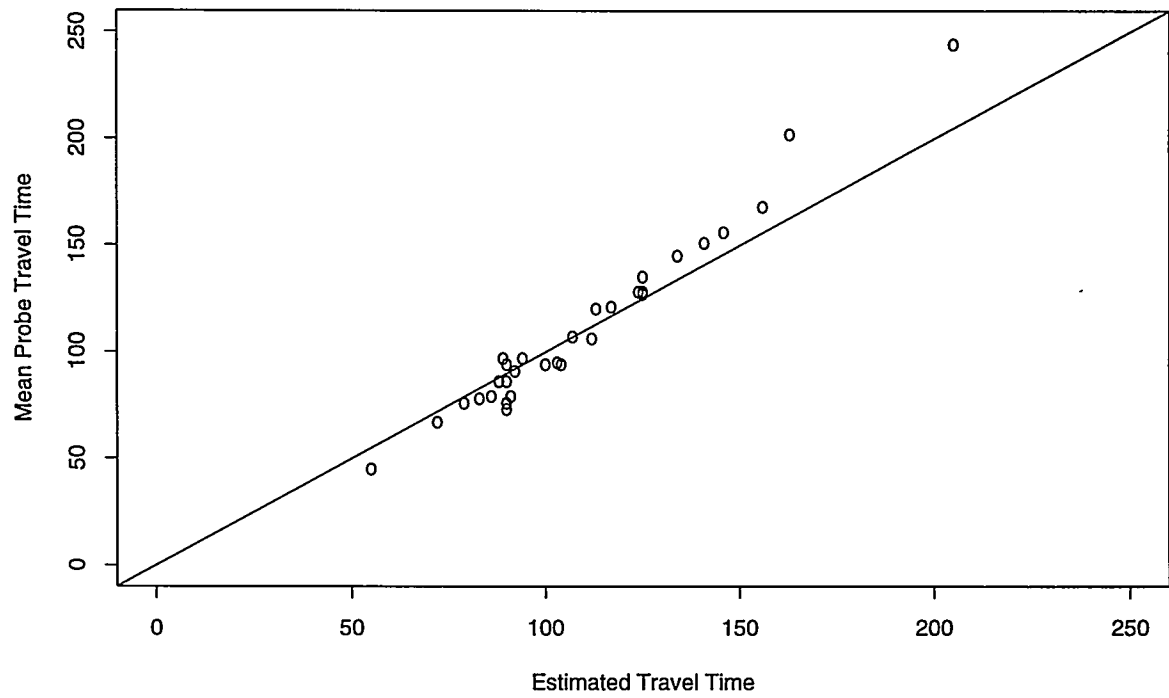

Figure 30: Difference between Probe and Estimated Travel Time: Link 7, Off-Peak, Deployment Level 5

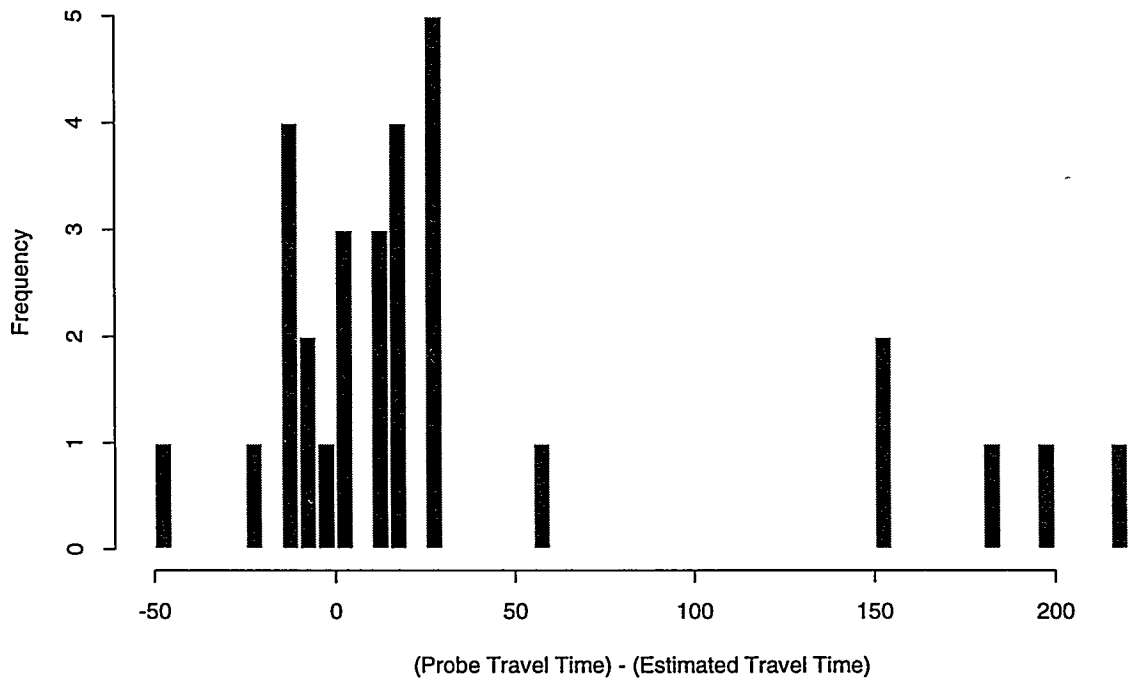
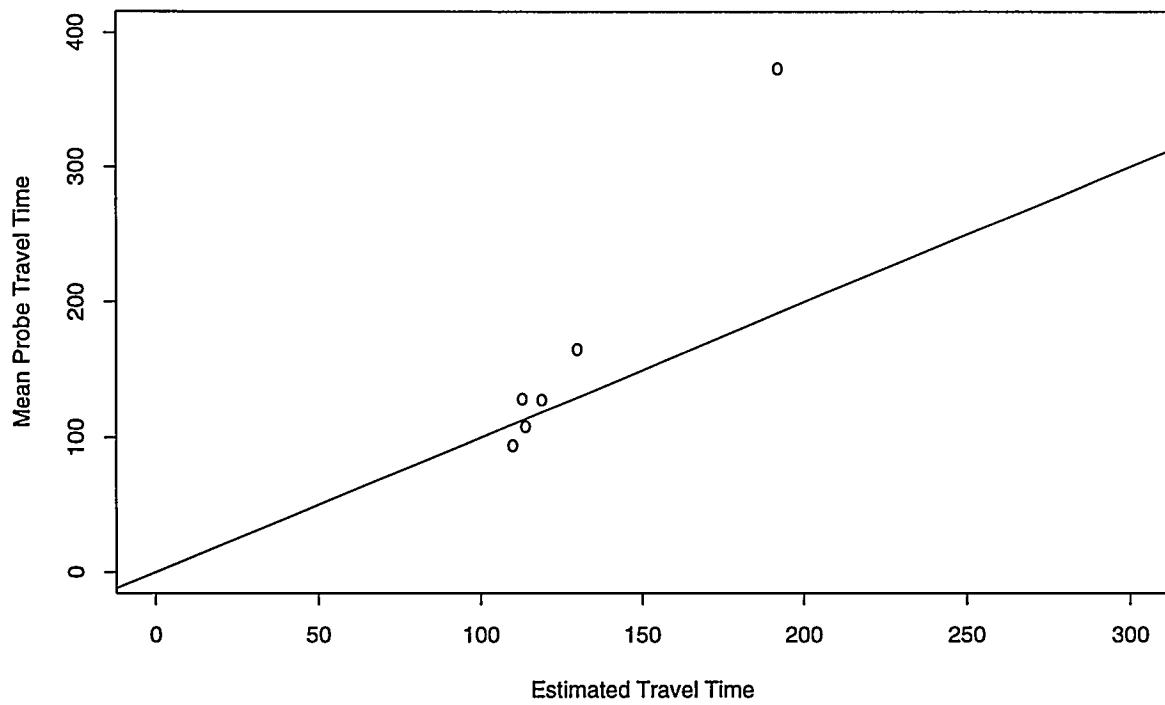

Figure 31: Difference between Probe and Estimated Travel Time: Link 7, Peak, Deployment Level 5

8.2.4 Overall Analysis of Various Deployment Levels

Several conclusions can be drawn from the above analysis. It is easier to comment on the off-peak case, comments on the peak case are less valid due to the paucity of data available. Marginal increases in quality, observable from the slope of the line in Figure 32, appear to peak at Level 1; at Level 5, this increase is lower. It appears possible that when DTTC is combined with probe data, the marginal effectiveness of increased deployment in promoting result quality peaks at Level 1, and then drops. It is possible that these marginal gains in quality could eventually be superseded by costs of deployment. Thus, the nature of the problem is different in congested condition than in the moderately congested case. While the addition of a single probe report may even impair the estimate in the moderately-congested case, adding one probe report to the DTTC procedure significantly increases the quality of the output in the congested case.

Figure 33 illustrates this conclusion for the off-peak case. The top diagram in Figure 33 presents estimates which significantly diverge from mean travel times. In the second scattergram from the top, these same estimates are only about 100 seconds away from the mean travel time (in the worst cases). The bottom two diagrams present further improvements accompanying the increase in probe-deployment levels. As noted in the previous section, the greatest improvement in accuracy of estimates is for Deployment Level 3. This quality assessment can be seen in Figure 32.

Here we should note that the analysis of the quality of the estimate for higher levels of deployment (especially Level 5), is biased by the fact that the probe travel-time data used to assess the estimate come from the same data-collection exercise as the data used as the input for the DTTC and DF processes. However, as can be seen from Figure 6, the DF input is screened through the data-screening algorithm while the other data set is not. The simplistic screening algorithm applied to the latter data is quite different from the Data Screening algorithm.

The analysis of means and standard deviations of the differences between the travel time estimate and the mean probe travel time presented in Table 8 shows that the bias is consistently positive for all deployment levels. As with the moderately-congested case, the phenomena in this situation are most likely due to the fact the the DTTC model was calibrated using very small data samples (a very large data sample was not available at that time). The bias for Level 1 (with probe data) is slightly higher than the bias for those estimates based on DTTC alone; the bias from Level 0 (without probe data) is 8.0. Other than this observation, the bias decreases with the increased deployment level.

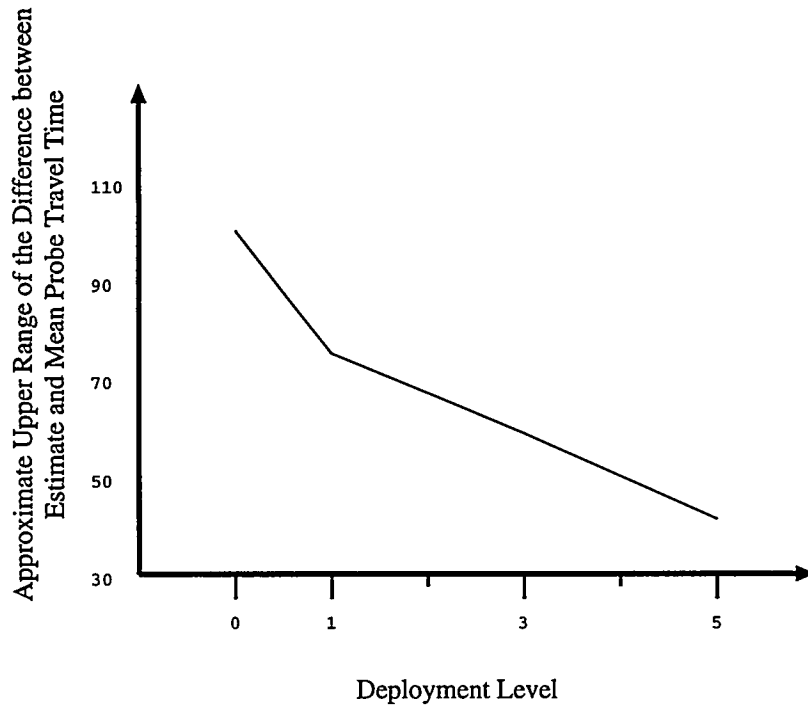
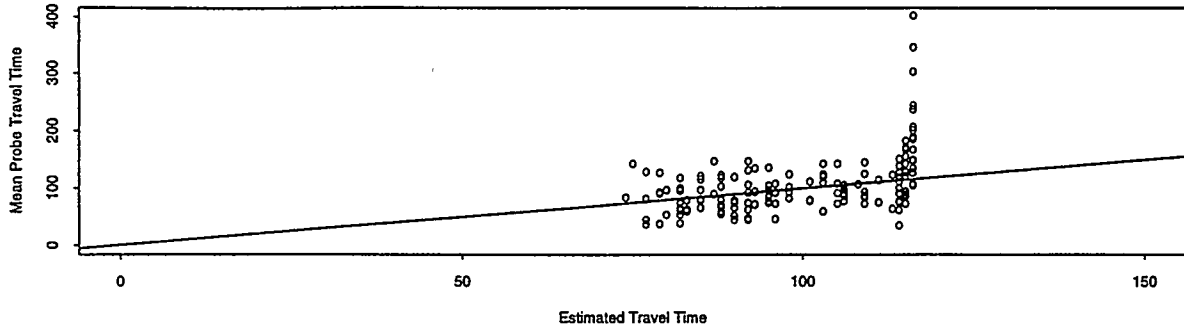

Figure 32: Changes in Estimate Quality by Deployment Level, Off-Peak, Congested Case

Note: As our analysis covered only deployment levels 0, 1, 3 and 5 the average difference between probe and estimated travel times for deployment levels 2 and 4 can only be approximated by this curve.

Detector Data Only, Off-Peak, Link 7



Probe and Detector Data, Deployment Level 1, Off-Peak, Link 7

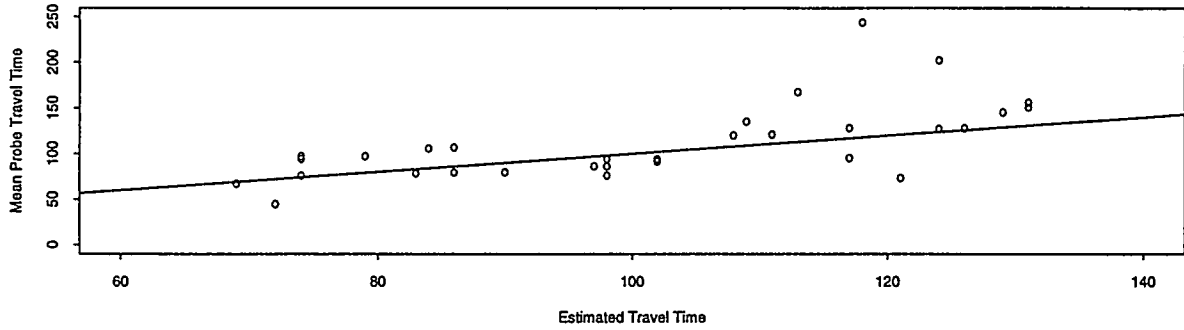

Probe and Detector Data, Deployment Level 3, Off-Peak, Link 7

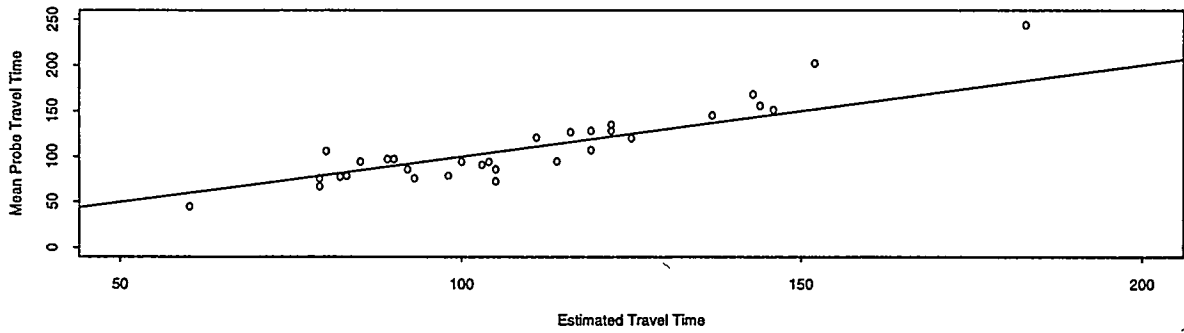

Probe and Detector Data, Deployment Level 5, Off-Peak, Link 7

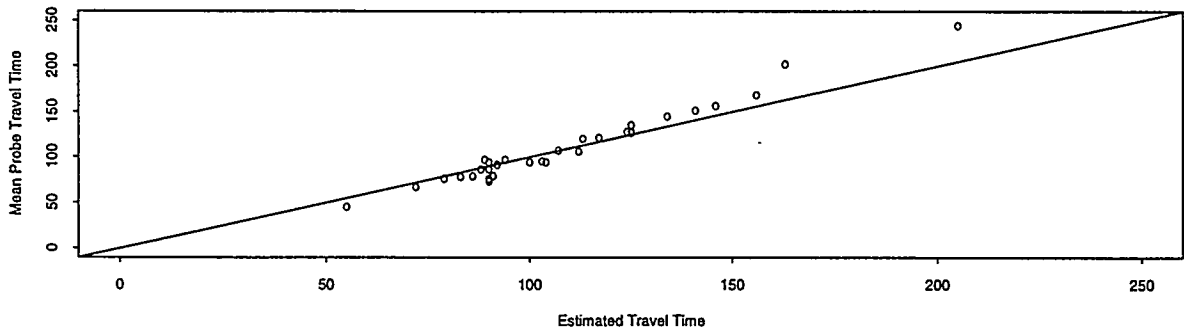

Figure 33: Estimated Travel Time vs. Probe Travel Time: Link 7, Off-Peak, All Deployment Levels

Table 8: Summary Characteristics of Differences Between Travel-Time Estimates (Congested Case) and Mean Probe Travel Times.

| Deployment Level | Link | Mean | Variance | Standard Deviation |
|------------------|------|-------|----------|--------------------|
| 0 | 7 | 8.038 | 2540.67 | 50.405 |
| 1 | 7 | 9.882 | 2167.24 | 46.554 |
| 3 | 7 | 2.097 | 1491.731 | 38.623 |
| 5 | 7 | 1.796 | 1264.088 | 35.554 |

9 Conclusions

The estimates of the link travel times produced by the DTTC and DF procedures are accurate as long as overcongested conditions do not persist over long periods of time. During the overcongested periods, the loop detectors do not provide any information on changes in traffic conditions. It is conceivable that we could develop a more advanced semi-dynamic DTTC algorithm which would yield reasonable estimates in this case, but it would require more data to be available for the calibration process than that which was available during the development of the TRF Data Fusion subcomponent of ADVANCE.

The comparison of the quality of the DTTC/DF estimates for various deployment levels suggests that the greatest improvement in using DF, when compared to using DTTC only, is visible for Deployment Level 3. However, for Deployment Level 1, the estimates are much better than without DF, especially for the cases when the quality of the DTTC estimate fused with probe data is lower (as in the case of prolonged congestion).

References

Berka, S., Tian, X., (1994) *Changes in Parameters of Data Fusion Subcomponent, Memo*, Urban Transportation Center, University of Illinois at Chicago.

Berka, S., Tian, X. and Tarko, A., (1995) *Data Fusion Algorithm for ADVANCE Release 2.0*, ADVANCE Working Papers Series, Number 48, Urban Transportation Center, University of Illinois, Chicago.

Berka, S., Sheffey, A. and Sen, A., (1996) *ADVANCE Evaluation: Data Screening*, Urban Transportation Center, University of Illinois, Chicago.

Hicks, J.E., Boyce, D.E., Sen, A., (1992) *Static Network Equilibrium Models and Analyses of Dynamic Route Guidance Systems*, A Technical Report in Support of the Design Phase of the ADVANCE Project, Urban Transportation Center, University of Illinois, Chicago.

Sen, A., et al, (1996) *ADVANCE Evaluation: Base Data and Static Profile*, Urban Transportation Center, University of Illinois, Chicago.

Sööt, S. and Condie, H., (1996) *ADVANCE Evaluation, Quality of Probe Reports*, Urban Transportation Center, University of Illinois, Chicago.

Urban Transportation Center, (1995) *Detector Travel Time Conversion and Fusion of Probe and Detector Data, Evaluation Test Plan*, University of Illinois, Chicago.

APPENDIX F

ADVANCE

**Advanced Driver and Vehicle
Advisory Navigation Concept**

Traffic Related Functions
Evaluation Report (6 of 7)
Documents # 8460.00

CONTAINS:

| | |
|--|--------------------------|
| Base Data and Static Profile Evaluation Report | -- Document # 8460-01.01 |
| Data Screening Evaluation Report | -- Document # 8460-02.02 |
| Quality of Probe Reports Evaluation Report | -- Document # 8460-03.01 |
| Travel Time Prediction and Performance of Probe and Detector Data Evaluation Report | -- Document # 8460-04.01 |
| Detector Travel Time Conversion and Fusion of Probe and Detector Data Evaluation Report | -- Document # 8460-05.01 |
| • Frequency of Probe Reports Evaluation Report | -- Document # 8460-06.01 |
| Relationships among Travel Times Evaluation Report | -- Document # 8460-07.02 |

Prepared by
University of Illinois-Chicago
Urban Transportation Center

DISCLAIMER

This report was prepared by a contractor for
Argonne National Laboratory
and is published as it was received.

ADVANCE Evaluation

Frequency of Probe Reports

Ashish Sen

URBAN TRANSPORTATION CENTER
University of Illinois at Chicago
1033 West Van Buren Street
Suite 700 South
Chicago, Illinois 60607

August 1996

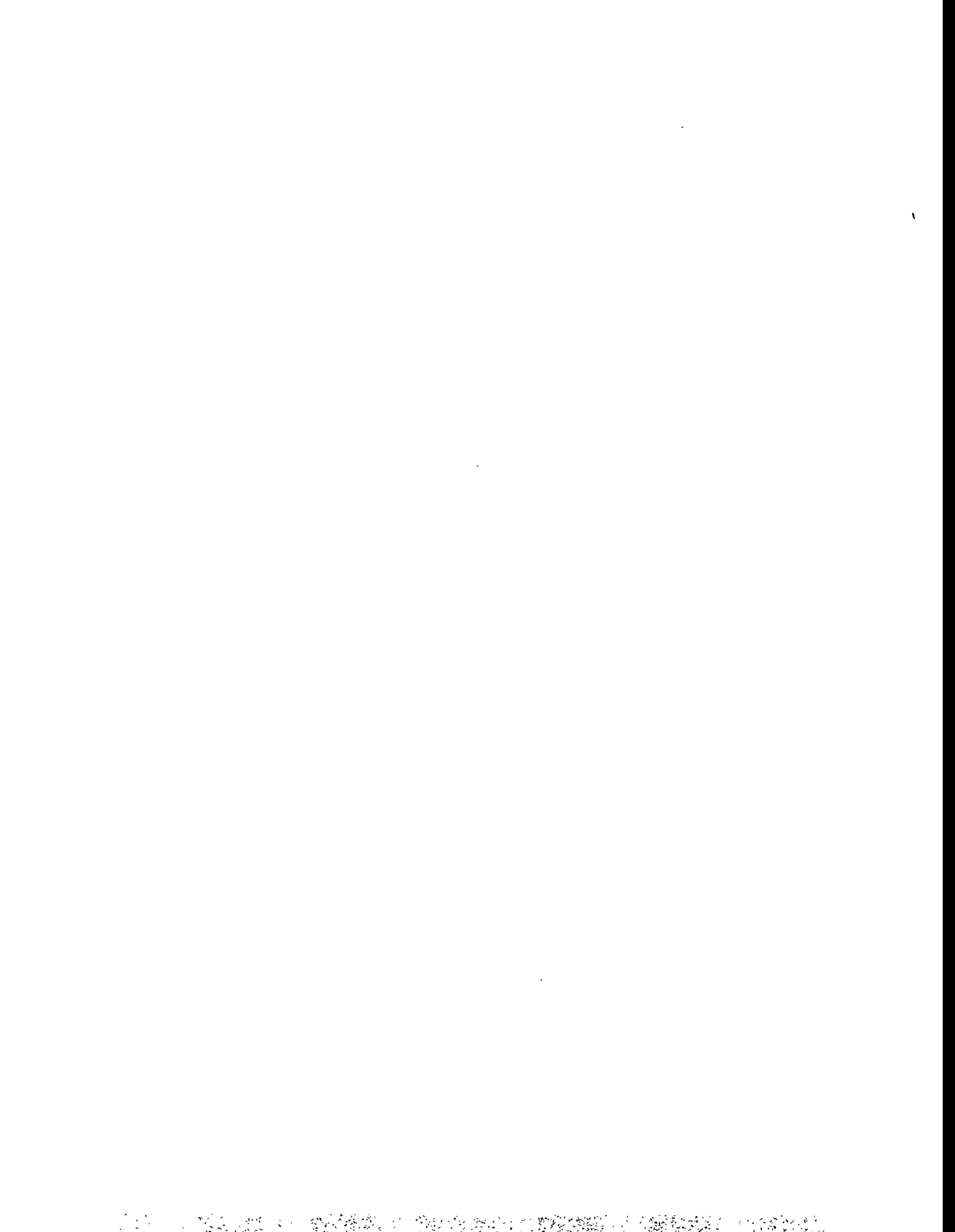

Executive Summary

A key piece of information for probe-based automatic traveler-information systems (ATIS) is the level of deployment required to obtain good quality travel time estimates. Issues relating to this are discussed in this report.

While a complete answer to the question can only be conjectured, better answers can be given to the question: how many probes per time interval are needed to obtain good quality link travel-time estimates.

The question is rendered difficult by the fact that probe reports of travel times are not statistically independent making it impossible to use formulæ from introductory statistics which assume independence. A synthetic method is therefore used to estimate the relationship between estimate quality (as measured by variance) and the number of probe reports per time interval.

It is shown that the variance of estimates never goes to zero regardless of the number of probes. Moreover, the quality of estimates essentially stops improving after a fairly small number of probe traversals. This indicates that very high levels of probe deployment might not be necessary for an effective probe-based ATIS.

Because of the fact that one must always tolerate fairly high variances, the architecture used in ADVANCE — specifically not broadcasting dynamic estimates until they differ adequately from static estimates — is indeed most appropriate. However, for future ATIS deployment we recommend that information on signal time changes and the times when probes exit links be used. The quality of estimates and hence of route guidance will be considerably improved.

Based on the study we come to the informal conclusion that the full deployment would have worked quite well. Although slightly higher levels of deployment would have enhanced the quality of guidance, considerably higher levels would not have yielded much additional improvement.

Contents

| | | |
|----------|--|-----------|
| 1 | Introduction | 1 |
| 2 | Study Area and Data Collection | 1 |
| 2.1 | Study Area and Routes | 1 |
| 2.2 | Data-Collection Schedule | 3 |
| 3 | Probe-Deployment Considerations | 6 |
| 4 | Results | 12 |
| 4.1 | Variance of Mean Link Travel Times | 12 |
| 4.2 | Test of No-Correlation Hypothesis | 13 |
| 4.3 | Estimation of Parameters | 18 |
| 4.4 | Implications of Dependence | 18 |
| 5 | Recommendations | 22 |

List of Figures

| | | |
|----|---|----|
| 1 | Probe Data Collection: Long Route | 2 |
| 2 | Probe Data Collection: Short Route | 3 |
| 3 | Probe Data Collection: Turning-Relationships Links | 4 |
| 4 | Travel Times on Link 11: July 17, 1995 | 8 |
| 5 | Relationships between Travel-Time Differences on Contiguous Links | 9 |
| 6 | Mean Travel Times on Links, 9, 10 and 11 | 10 |
| 7 | Plot of $[\bar{e}_{d,t}]^2$ against $1/n$ for Link 1 during the Peak Period | 15 |
| 8 | Plot of $[\bar{e}_{d,t}]^2$ against $1/n$ for Link 11 during the Peak Period | 16 |
| 9 | Relationship between Standard Error $s.e.[\bar{x}]$ and Frequency n of Probes on Link 32 during the Peak Period Estimated from the Model $[\bar{e}_{d,t}]^2 = \nu + \gamma_1[1/n_{d,t}] + \epsilon_{d,t}$ | 19 |
| 10 | Relationship between Standard Error $s.e.[\bar{x}]$ and Frequency n of Probes on Link 11 during the Peak Period Estimated from the Model $[\bar{e}_{d,t}]^2 = \nu + \gamma_1[1/n_{d,t}] + \epsilon_{d,t}$ | 20 |

List of Tables

| | | |
|---|--|----|
| 1 | MNA Reports by Link | 4 |
| 2 | Probe Reports for each day of Data Collection | 5 |
| 3 | Probe Reports for each hour of Data Collection | 6 |
| 4 | Estimates from Day/Time-of-Day Model for the Peak Period | 17 |
| 5 | Estimates from Day/Time-of-Day Model for the Off-Peak Period | 18 |

1 Introduction

The purpose of this report is to provide an assessment of the number of probes that would be required to obtain reasonable estimates of link travel times. Since link travel times may be obtained in many different ways, this report is essentially confined to the way such estimates were constructed for the ADVANCE demonstration project — and only for recurrent congestion. Specifically, the report focuses on means of probe-reported travel times over five-minute time intervals under incident-free conditions, since such estimates constitute the building blocks for dynamic route guidance. Incidents have been evaluated in a separate report.

Assessing what sample size renders the mean of a set of numbers sufficiently reliable for a given purpose might appear to be a trivial exercise in elementary statistics. However, this is not the case for several reasons, the principal one being that probe travel-time reports are not statistically independent, a requirement of the usual formulæ found in introductory statistics textbooks. This and other issues are elaborated on in Section 3, in which the various factors that influence the quality of travel-time estimates are described. Unfortunately, the results obtained from this study are link specific. Generalization to links that were not studied does not appear to be trivial.

However, because the links studied included a wide range of congestion levels, some qualitative statements can be made. One of these is that the deployment level originally planned for full deployment would have been adequate to provide fairly good dynamic information. Deployment levels four or five times higher would yield significantly better information. Above that, while information quality would continue to improve with deployment, the improvements would be slight.

2 Study Area and Data Collection

In early 1995 a decision was made to go from a full deployment using 3000–5000 vehicles to be driven by volunteer drivers as they went about their daily lives, to a targeted deployment where fewer vehicles would be driven by paid drivers on strictly-defined routes. These routes and the data-collection exercise for this targeted deployment are described below.

2.1 Study Area and Routes

The entire routes driven on Dundee Road and adjacent arterials were within the municipality of Wheeling, Illinois (north suburban Chicago). Dundee Road was selected because it carries a high volume of traffic and because each signalized intersection is demand actuated by loop detectors (including turning lanes) and there are volume and occupancy detectors in several locations. Although Dundee Road extends for several miles within the ADVANCE study area the number of potential locations along Dundee Road where

the necessary field tests could be performed was very limited. The data-collection route required a convenient location where vehicles could turn around safely and avoid being off the study route for a long period of time. The route also needed a mix of link and intersection characteristics.

Two route configurations were used for the field data collection. The first route is the long route and was used for the majority of tests (Figure 1). The long route consists of twelve links. The section of the route on Schoenbeck Road and Palm Drive (near the west end) was used as a staging and turnaround area and, since it was too short to complete a recognized link, data were not collected for this section of the route. The route was selected to be completed during a fifteen-minute period. This provided the desired frequency of probe reports. Given the limited size of the driving fleet a longer route would not provide the frequency of reports needed for most tests performed because too few vehicles would be available for dispatch at the required headways. During the off-peak period the majority of the drivers completed this twelve-link route in ten to fourteen minutes.

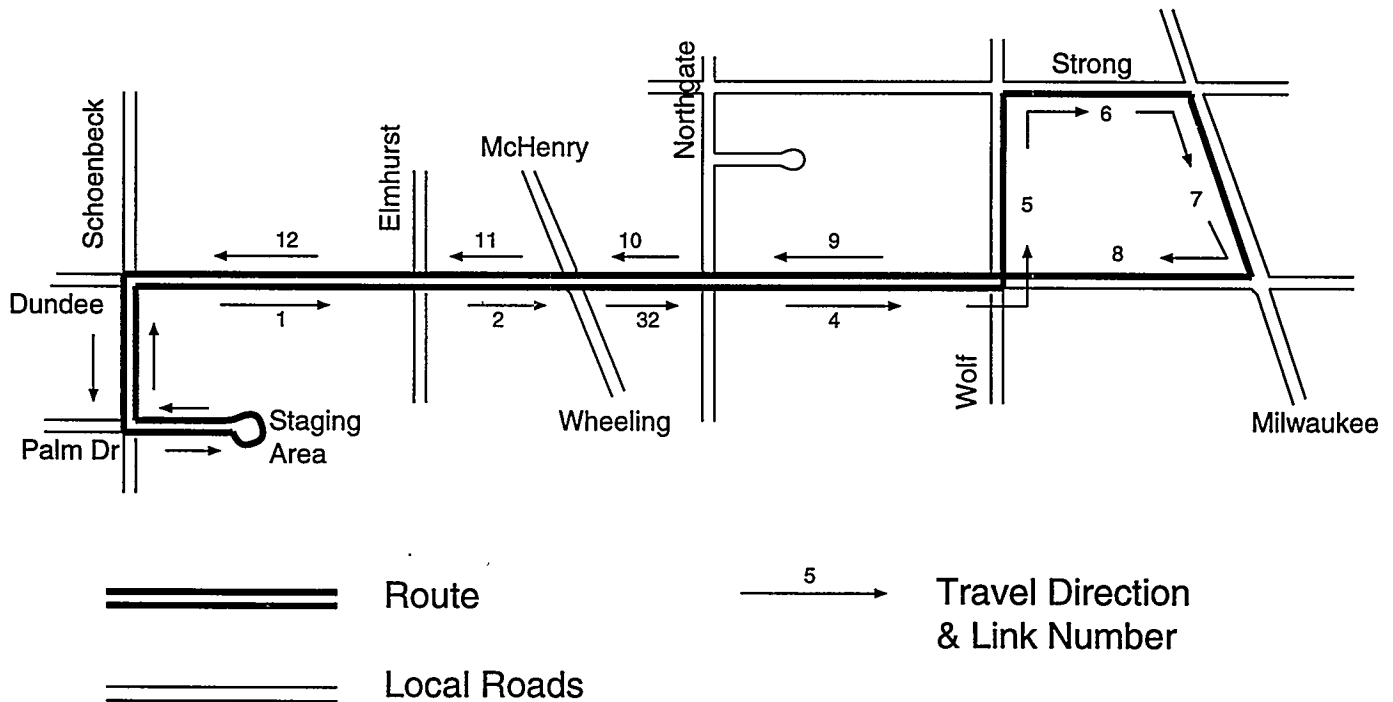

Figure 1: Probe Data Collection: Long Route

During the peak period this route proved to be too long to complete in fifteen minutes and a shorter alternative was used. This is shown in Figure 2. Even the short route could not always be completed in fifteen minutes but this happened infrequently.

Links 4 through 9 are on the long route but do not have the same number of link reports for two reasons (Table 1). First, many of the scheduled rest breaks were taken on this portion of the route. The most common break location was on Link 8 and there

Table 1: MNA Reports by Link

| Link | Frequency | Percent | Link | Frequency | Percent |
|------|-----------|---------|-------|-----------|---------|
| 1 | 5481 | 10.8 | 7 | 2323 | 4.6 |
| 2 | 6298 | 12.4 | 8 | 2172 | 4.3 |
| 3* | 5886 | 11.6 * | 9 | 2462 | 4.9 |
| 4 | 2313 | 4.6 | 10 | 6066 | 12.0 |
| 5 | 2294 | 4.5 | 11 | 7826 | 15.5 |
| 6 | 2293 | 4.5 | 12 | 5206 | 10.3 |
| 31* | 3555 | 7.0 * | | | |
| 32* | 2331 | 4.6 * | | | |
| | | | Total | 50,620 | 100.0 |

* Link 3 consists of two links, 31 and 32. Link 31 is on the short route and includes a left turn at the end of the link. Link 32 is on the long route and has a through movement at the end of the link (no turn).

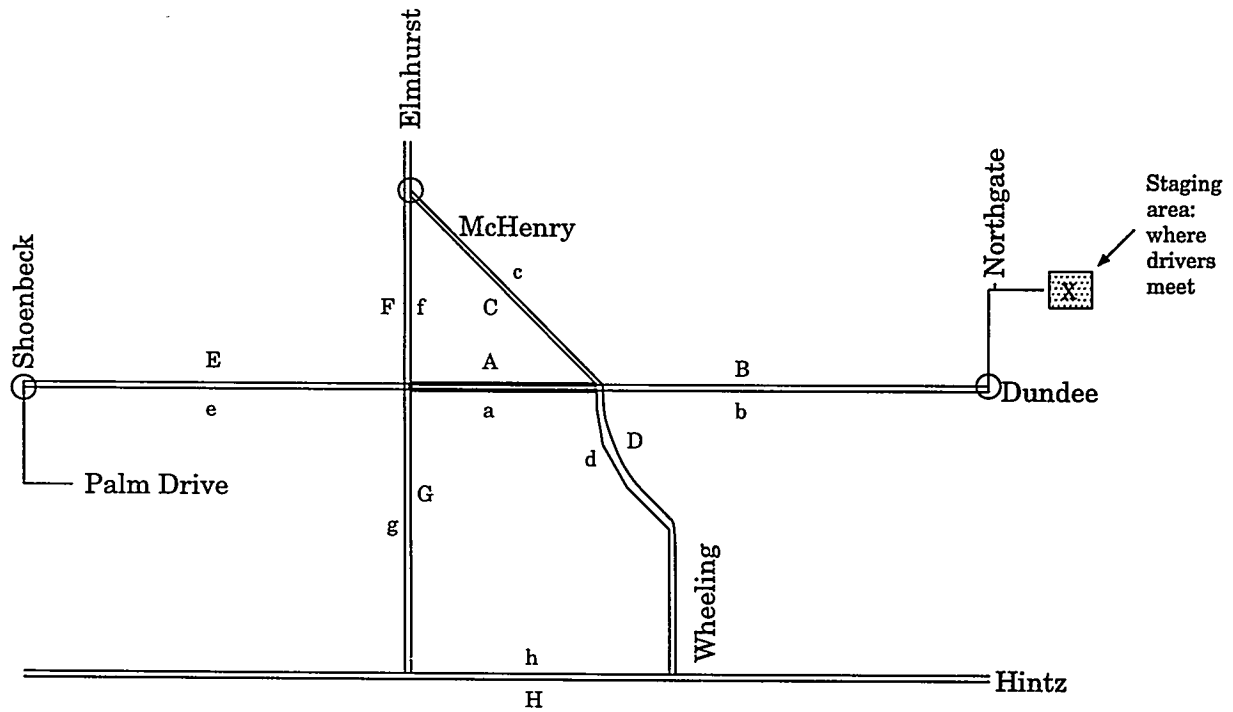

Figure 3: Probe Data Collection: Turning-Relationships Links

Table 2: Probe Reports for each day of Data Collection

| Date | No of Reports | Percent of Total |
|-------|---------------|------------------|
| 6/05 | 660 | 1.3 |
| 6/07 | 395 | 0.8 |
| 6/08 | 1140 | 2.3 |
| 6/12 | 1382 | 2.7 |
| 6/13 | 1712 | 3.4 |
| 6/14 | 1014 | 2.0 |
| 6/15 | 446 | 0.9 |
| 6/19 | 1178 | 2.3 |
| 6/20 | 1591 | 3.1 |
| 6/21 | 1503 | 3.0 |
| 6/22 | 2372 | 4.7 |
| 6/26 | 2037 | 4.0 |
| 6/27 | 1481 | 2.9 |
| 6/28 | 1744 | 3.4 |
| 6/29 | 1546 | 3.1 |
| 7/05 | 1560 | 3.1 |
| 7/06 | 1996 | 3.9 |
| 7/10 | 1689 | 3.3 |
| 7/11 | 1282 | 2.5 |
| 7/12 | 1507 | 3.0 |
| 7/13 | 1046 | 2.1 |
| 7/17 | 2285 | 4.5 |
| 7/18 | 2252 | 4.4 |
| 7/19 | 2140 | 4.2 |
| 7/20 | 1901 | 3.8 |
| 7/24 | 880 | 1.7 |
| 7/25 | 907 | 1.8 |
| 7/26 | 1017 | 2.0 |
| 7/27 | 899 | 1.8 |
| 7/31 | 949 | 1.9 |
| 8/01 | 1069 | 2.1 |
| 8/02 | 1038 | 2.1 |
| 8/03 | 1139 | 2.3 |
| 8/04 | 949 | 1.9 |
| 8/07 | 1058 | 2.1 |
| 8/08 | 1050 | 2.1 |
| 8/09 | 873 | 1.7 |
| 8/10 | 933 | 1.8 |
| Total | 50,620 | 100.0 |

with the routes to and from the study area. Data were collected by probe vehicles driven in the study area between 1:00 pm and 7:00 pm (Table 3), with breaks as described below.

Table 3: Probe Reports for each hour of Data Collection

| Hour Beginning | No of Reports | Percent of Total |
|----------------|---------------|------------------|
| 1:00 pm | 8464 | 16.7 |
| 2:00 pm | 7980 | 15.8 |
| 3:00 pm | 5187 | 10.2 |
| 4:00 pm | 8488 | 16.8 |
| 5:00 pm | 8433 | 16.7 |
| 6:00 pm | 7871 | 15.5 |
| 7:00 pm | 4197 | 8.3 |
| Total | 50,620 | 100.0 |

On each day of data collection a field manager was present at the staging area. The field manager ensured that vehicles were driving the study route at satisfactory headways and instructed drivers when to take breaks. The field manager also assisted with other problems which routinely occurred.

The drivers were given a ten-minute break at approximately 2:00 pm to 2:10 pm and another one from approximately 6:00 pm to 6:10 pm. Each driver took his or her break at a slightly different time, as each was dispatched by the field manager to the break area as they arrived at the staging area. During breaks each probe vehicle was inactive for more than ten minutes as time was lost off-route and also while the vehicle and MNA warmed up. The longest break occurred from 3:30 pm to 4:00 pm. After this break, during the two-hour peak period from 4:00 pm to 6:00 pm, the drivers operated their vehicles without scheduled breaks.

3 Probe-Deployment Considerations

Since in a probe-based ATIS, information on the condition of the network is obtained from probes, a key issue with respect to the future of such systems is the deployment level needed for the system to function well. This section contains a listing of the issues involved in a discussion of deployment levels.

The decision (described above) to proceed with a targeted deployment of probe vehicles saved several million dollars and in many ways the experience gained from the targeted deployment was not significantly less than that which would have been gained from a full deployment. One element that did suffer was an understanding of the level of deployment needed for a well functioning probe-based ATIS. This is not to say that the additional cost of a full deployment could have been justified on this ground; indeed, it possibly could

not have been and perhaps simulation and other methods can be used effectively for this purpose. However, the fact remains that in the evaluation effort which is the subject of the present report, we can offer only a partial answer to the question of what level of probe deployment would be satisfactory.

Since the targeted deployment can give us good information on the links on which probe-reported travel times were recorded we can give answers at a link level. We have attempted to do so in this report. However, a gap remains between link level answers and total system level answers. This section identifies some of the issues involved along with some link level issues.

Several factors need to be considered in order to identify satisfactory probe deployment levels:

- A very important factor is coverage, i.e., the number of links being covered during an appropriate time interval. This issue was addressed in one of the first documents written for ADVANCE design (Hicks, Boyce and Sen, 1992) and the deployment level was chosen in accordance with that study. It is not discussed further here.

It should however be borne in mind that links not covered are mostly less-traveled links. Such links are less likely to suffer from congestion and, given the nature of the route-choice algorithm used, are less likely to form part of routes that are recommended to drivers.

- The considerations just mentioned apply to links which do have positive numbers of probes, in the sense that more important links would get higher traversal levels per unit time.
- There are enormous variations in probe-reported travel times even within a single traffic-signal cycle. Under conditions of no cycle failure, a vehicle arriving at an intersection at the end of the green time experiences little delay and hence shorter link travel times than one that arrives at the start of the red. Figure 4 illustrates this situation for one of the links on our study route, Link 11, on July 17. The high travel-time observations are for probes arriving during the red phase and the low observations for those arriving late in the green phase. Note that the figure would appear different if progression were to be different.

While the variance would depend on progression and the proportion of vehicles entering the link via left and right turns, the fact remains that the variance of link travel times would be high.

- Given the above fact, estimating a single number 'link travel time' over a time interval becomes difficult. Such travel time variations are a normal occurrence and affect any discussion regarding link travel times.
- However, we would be more interested in route travel times, rather than the travel times on individual links. A route travel time is the sum of travel times on links

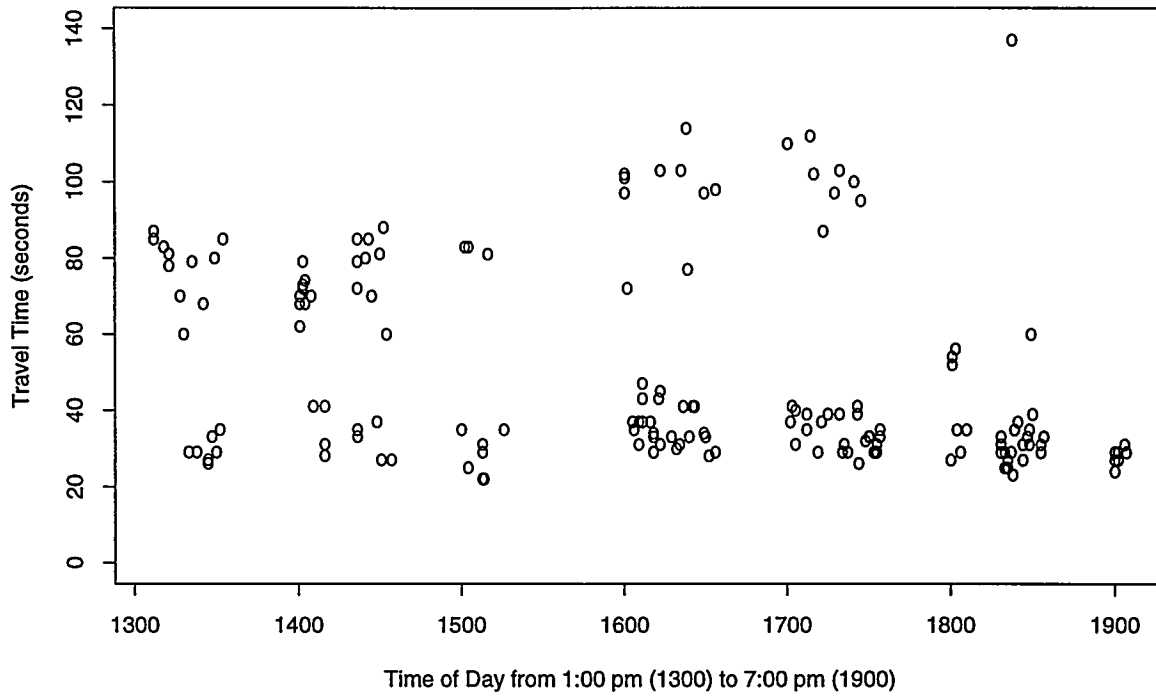

Figure 4: Travel Times on Link 11: July 17, 1995

comprising that route. Thus we would normally conjecture that if an average travel time per link is supplied, the discrepancies between the travel times actually encountered by a vehicle and the average would partially 'cancel out' as we add them over a large number of links comprising the route.

This is not an unusual experience for drivers and would be true if link travel times were independent. However, travel times on contiguous links are not usually independent and depend on progression. Consider the plots of travel times on pairs of links shown in Figure 5. Each point on these plots shows link travel times for the same vehicle on two contiguous links. The plot on the left shows the travel times for each probe vehicle on Links 1 and 2. It may be seen from this plot that when the travel time on Link 1 is high the travel time on Link 2 is low, and vice versa. In this case when a vehicle is stopped at a red light on one link, it nearly always gets a green on the next.

The plot on the right shows the travel times for each probe vehicle on Links 5 and 6. The travel times on these two links are highly correlated and represent a very different situation from the previous example. It may be seen from this plot that when the travel time on Link 5 is high the travel time on Link 6 is also high. In this case each vehicle seems to take its surrounding congestion with it onto the next link.

There are also cases where a traffic signal acts as a flow-control valve for congestion; a congested link is followed by an uncongested one. This can be seen on Figure 6 which shows the mean travel time for each time-of-day interval for Links 9, 10 and

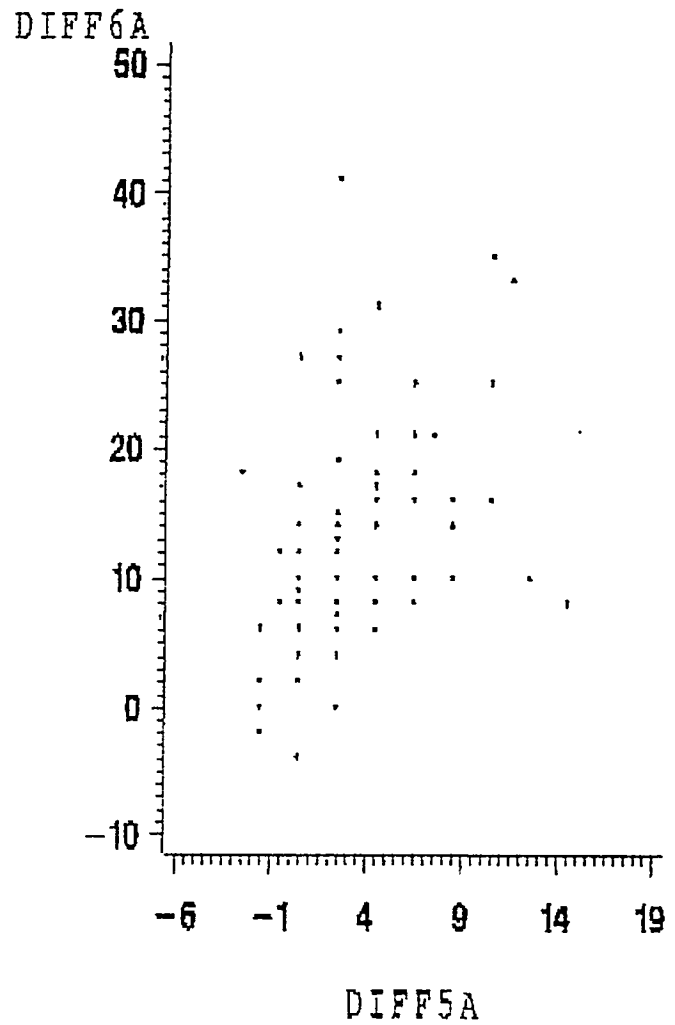
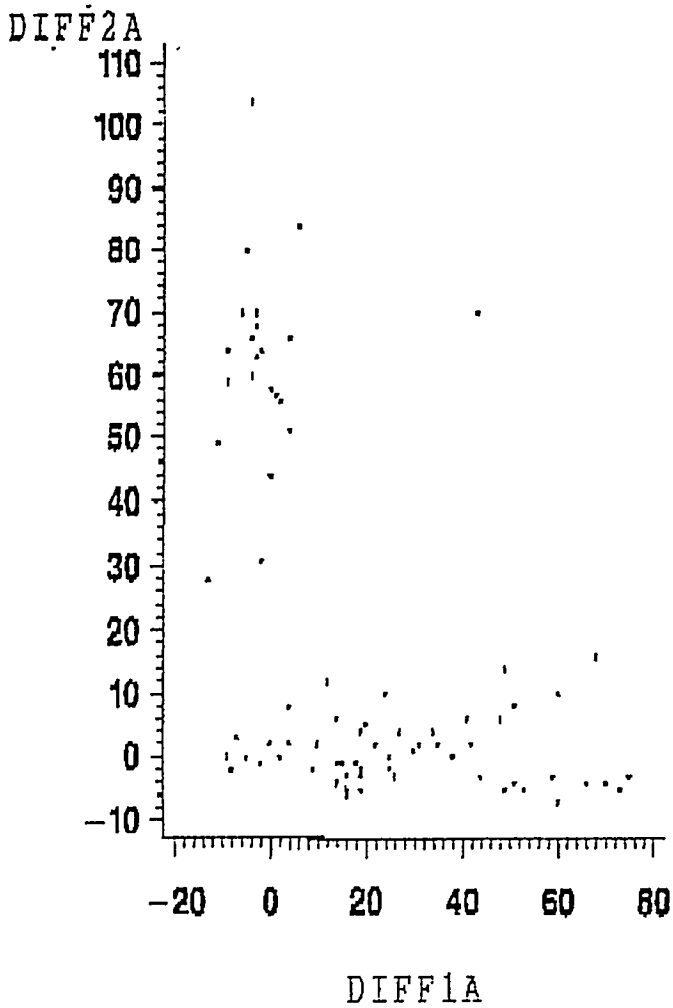
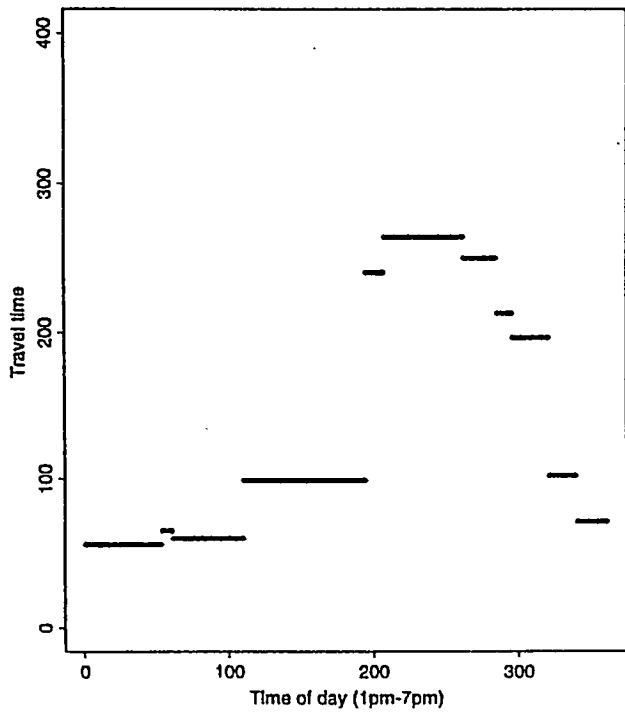

Figure 5: Relationships between Travel-Time Differences on Contiguous Links

Note: DIFF1A on the x-axis of the plot on the left is the travel time for each vehicle on that link less the cruise time on the link. The cruise time is equal to link length/speed limit. Similarly, DIFF2A, DIFF5A and DIFF6A give the travel time less the cruise time on Links 2, 5 and 6. Each point represents a vehicle's travel times on two contiguous links.

Link 9



Link 10

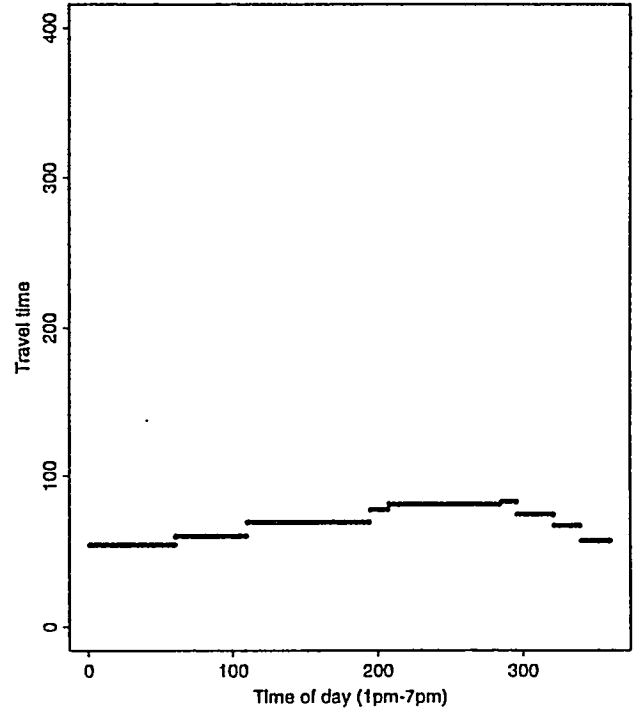

Link 11

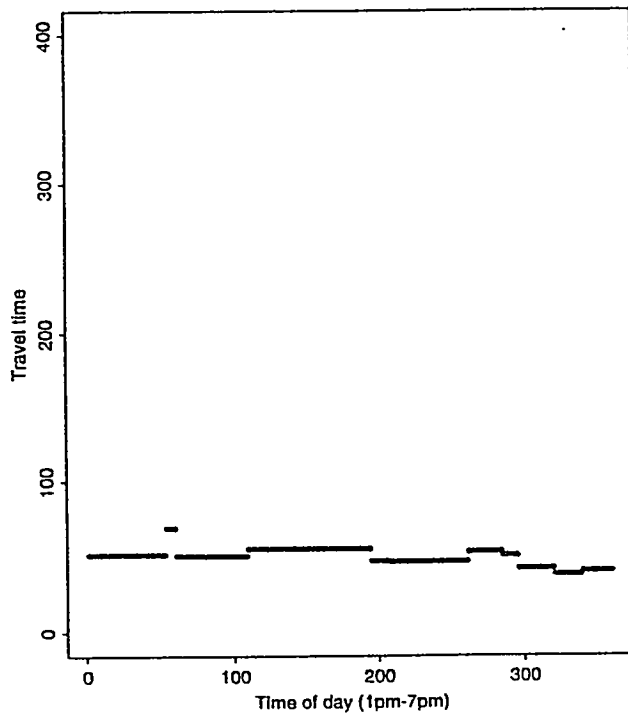

Figure 6: Mean Travel Times on Links, 9, 10 and 11

11. Figure 6 shows high travel times on Link 9 during the peak period, indicating the presence of peak-period congestion on this link. This is not evident for Links 10 and 11.

These examples illustrate that the variation in travel times which exists for one link may well be substantially lower for an entire route. Even when congestion occurs for a few links, it may not exist on a subsequent link.

- Returning to the case of individual links, the formula:

$$\text{Travel Time} = \text{Cruise Time} + \text{Signal Delay}$$

seems to hold fairly well. The cruise time for a typical fairly long link (of around 800 meters) with a short average queue at the end of it seems to be close to constant.

The delay encountered by one vehicle in a queue would be very similar to those encountered by neighboring cars in the same queue so long as they depart the link in the same cycle. Thus, very high sample sizes should not be required to estimate link travel times.

- Under moderate to low congestion two vehicles arriving at the beginning of the red signal phase would tend to have similar travel times, regardless of cycle. Similarly, two vehicles arriving during the latter part of the green phase would tend to have similar travel times. In fact, under low and moderate congestion signal phases have an enormous effect on probe-recorded travel times.

Clearly, if probe arrival times or exit times were precisely recorded and times of phase changes of traffic signals were known, the effect of traffic signals could be corrected for. Indeed, we make the recommendation that in future ATIS design such information be obtained and incorporated into travel-time estimation algorithms.

Since in the ADVANCE system time intervals over which estimates are made are of fixed length and different intervals include different proportions of red and green phases, averages of probe-reported travel times would tend to vary from interval to interval for this reason and *increasing the number of probes will not substantially reduce this variation*. Therefore, in the ADVANCE system some variance in estimates will have to be tolerated and increasing the number of probes will not necessarily reduce this.

This fact and the one described in the last item are demonstrated mathematically in Section 4.

It may be mentioned that these problems do not substantially affect static forecasts, which, although they do not reflect current conditions, are inherently more reliable than dynamic estimates. This fact has been noted in several different elements of ADVANCE evaluation. The ADVANCE design takes account of this very well by broadcasting dynamic updates only when dynamic estimates substantially differ from static updates.

After this discussion of the issues, in the rest of this report we focus on the relationship between frequency of probe reports and the variance of mean travel-time estimates. This relationship is complicated by the lack of independence of probe reports as described above. However, empirical relationships can be obtained and are presented.

ADVANCE used a 5-minute time interval and therefore the discussion in this report focuses only on this interval. A longer interval would trap more probes and by including more cycles could improve estimates. On the other hand longer intervals would not be able to handle small variations in travel times and would therefore make estimates supplied to vehicles less current.

4 Results

As mentioned earlier, for each link and for each (5-minute) time interval, means of the link travel times from different vehicles are computed and act as building blocks for most of the route-guidance information supplied to in-vehicle MNAs. If a link is detectorized, then data from detectors and from probe vehicles are used to estimate link travel-time estimates. For links without detectors (most links are not detectorized) mean travel times from probe data only are supplied to vehicles as ‘current travel times.’ Forecasts of link travel times made for 5, 10 and 15 minutes into the future are also computed. Five-minute means are used as inputs in the formulæ used for constructing these forecasts. Therefore, the key statistic is mean link travel time over each 5-minute interval and the rest of this discussion is focused on this estimate.

4.1 Variance of Mean Link Travel Times

The variance of the mean $\bar{x} = n^{-1} \sum_{i=1}^n x_i$ of (5-minute mean) probe-reported travel times, x_1, x_2, \dots, x_n , for the same link over some time interval is

$$\begin{aligned}
 \text{var} [\bar{x}] &= E[\bar{x} - E(\bar{x})]^2 = E[n^{-1} \sum_{i=1}^n (x_i - E[x_i])]^2 \\
 &= n^{-2} E[\sum_{i=1}^n (x_i - E[x_i])^2 + \sum_{\substack{i,j \\ i \neq j}} (x_i - E[x_i])(x_j - E[x_j])] \\
 &= n^{-2} \sum_{i=1}^n \text{var} [x_i] + \sum_{\substack{i,j \\ i \neq j}} \text{Cov} [x_i, x_j]
 \end{aligned} \tag{1}$$

where $\text{Cov} [\cdot]$ stands for covariance. Let $\eta = n^{-1} \sum_{i=1}^n \text{var} [x_i]$ be the average variance of x_i 's and let

$$\nu = [n(n-1)]^{-1} \sum_{\substack{i,j \\ i \neq j}} \text{Cov} [x_i, x_j]$$

be the average covariance of all pairs (x_i, x_j) . Then, (1) may be written as

$$\begin{aligned}\text{var}[\bar{x}] &= n^{-2}[n\eta + n(n-1)\nu] = \eta n^{-1} + [1 - n^{-1}]\nu \\ &= \nu + n^{-1}[\eta - \nu].\end{aligned}\tag{2}$$

Of course, if the covariances were zeros, then $\nu = 0$, and we would get $\text{var}[\bar{x}] = n^{-1}\eta$, and if all variances of x_i were equal to σ^2 , then we would get the familiar $\text{var}[\bar{x}] = n^{-1}\sigma^2$. In this case as $n \rightarrow \infty$, $\text{var}[\bar{x}] \rightarrow 0$, as is very well known. On the other hand, if the correlation between every pair of x_i 's were one and all variances were equal, then for all i and j , $\text{Cov}[x_i, x_j] = \text{var}[x_i]$ and $\nu = \eta$. Then $\text{var}[\bar{x}] = \nu$ and then $\text{var}[\bar{x}] = \nu$ stays the same no matter what n is. This is to be expected, because then all the observations x_i would be exactly the same. In practice we would expect something in between, where $\eta > \nu > 0$. Even then as $n \rightarrow \infty$, $\text{var}[\bar{x}] \rightarrow 0$. While our discussion has been in terms of the mean, a similar situation would hold for most reasonable estimators.

The implication of these facts is that if $\nu > 0$, then no matter how many link travel times of distinct vehicles we measure over a short time interval, the variance of the mean would be large. Clearly, how large is a critical question and can be answered by examining values of ν 's. In fact, even if we computed the mean of all vehicles during a given time interval, the variance of the mean would remain above the value of ν for that link.

This might appear counter-intuitive, since when a sample becomes the same as the population one might expect the variance of the sample mean to go to zero. This does not happen here because each x_i is assumed to be one out of a continuum of (and hence an infinite number of) random variables. This is appropriate for forecasting applications, because it is not nearly as important for us to know what exactly the mean travel time for a given set of vehicles was during some interval in the past as to know what travel times will be in the future if similar conditions persist. For this purpose, sets of travel times need to be considered as samples from an infinite population.

4.2 Test of No-Correlation Hypothesis

While in Section 3 we have given the underlying causes of a lack of independence, it is perhaps appropriate to formally test the hypothesis of no correlation against the presence of correlation. If the x_i 's were uncorrelated, the average covariance ν would be zero. Therefore, all we need to do is test if $\nu = 0$. One method of testing the hypothesis $H : \nu = 0$ against the alternative $A : \nu \neq 0$ is afforded by (2) itself. If we have reasonable estimates of $\text{var}[\bar{x}]$, we could regress this against the corresponding values of n^{-1} , where n is the number of observations used to compute \bar{x} . The intercept term would then be an estimate of ν and could be used to test H against A .

One estimate of $\text{var}[\bar{x}]$ is $[\bar{x} - \widehat{E}[\bar{x}]]^2$, where $\widehat{E}[\bar{x}]$ is an estimate of $E[\bar{x}]$. In order to estimate $\widehat{E}[\bar{x}]$, we used the model

$$E[x_{d,t}] = \gamma + \alpha_d + \beta_t,\tag{3}$$

where α_d and β_t are respectively day effects and time-of-day effects. The model (3) is implied by

$$E[x_{d,t,i}] = \gamma + \alpha_d + \beta_t \quad (4)$$

where $x_{d,t,i}$ is the i th observation during day d and time-period t . Model (4) can be estimated by least squares, after coding the independent variables corresponding to α_d 's and β_t 's as indicator (or dummy) variables (one indicator variable for each time interval t and one for each day d) with the restrictions $\sum_d \alpha_d = 0$ and $\sum_t \beta_t = 0$, in order to avoid multicollinearity. The residuals $e_{d,t,i}$ from (4) are

$$e_{d,t,i} = x_{d,t,i} - \hat{\gamma} - \hat{\alpha}_d - \hat{\beta}_t \quad (5)$$

where $\hat{\alpha}_d$ denotes an estimate of the parameter α_d . For every day and time period, the mean over all i of these residuals is therefore,

$$\bar{e}_{d,t} = \bar{x}_{d,t} - \hat{\gamma} - \hat{\alpha}_d - \hat{\beta}_t. \quad (6)$$

Thus, if (3) holds, a reasonable estimate of $[\bar{x} - E[\bar{x}]]$ is $\bar{e}_{d,t}$ and $[\bar{e}_{d,t}]^2$ estimates $\text{var}[\bar{x}]$. Therefore, the model estimated is

$$[\bar{e}_{d,t}]^2 = \nu + \gamma_1[1/n_{d,t}] + \epsilon_{d,t} \quad (7)$$

where the $\eta = \nu + \gamma_1$ and $\epsilon_{d,t}$ is the error term relating to the t th time interval on day d . These parameters may be estimated by some regression procedure. Thus a test of the hypothesis H against A could be conducted by using least squares to carry out the regression and then test $\nu = 0$ in the usual way using the t -statistic.

However, before conducting the estimation, we need to make sure that the underlying assumptions of least squares are at least approximately met. Figures 7 and 8 show plots of the dependent variable $y_{d,t} = [\bar{e}_{d,t}]^2$ against the independent variable n^{-1} for links 1 and 11 during the peak period. In these plots n is the number of probes per 5-minute interval; indeed all empirical work was done for 5-minute interval data in order to be consistent with ADVANCE design. It would appear that we have a wedge or funnel-shaped pattern of points indicating the presence of heteroscedasticity or unequal variance violating the assumption that $E[\epsilon_{d,t}^2] = \sigma^2$.

One solution to this problem is to weight the regression. In order to find appropriate weights, ignoring subscripts for the moment, we write the dependent variable as $y = u^2$ where $u = \bar{e}$, with \bar{e} as in (7). For any differentiable function $f(u)$, the variance $\text{var}[f(u)]$ of $f(u)$, may be approximately written as $\text{var}[f(u)] \approx [f'(z)]^2 \text{var}[u]$, where a prime denotes a derivative and z is the mean of u . Since $f(u) = u^2$ here, and an estimate of $\text{var}[u]$ is y , we get $\text{var}[f(u)] \approx 4E[y]^2 \propto E[y]^2$. Thus a proper weight would appear to be the reciprocal of the square of an estimate of $E[y]$. In our examination of diagnostics from the different regressions weighted as above, no heteroscedasticity was noticeable.

Notice that under the hypothesis of no correlation, the dependent variable values are only slightly correlated — the only correlation would be that due to the parameters γ ,

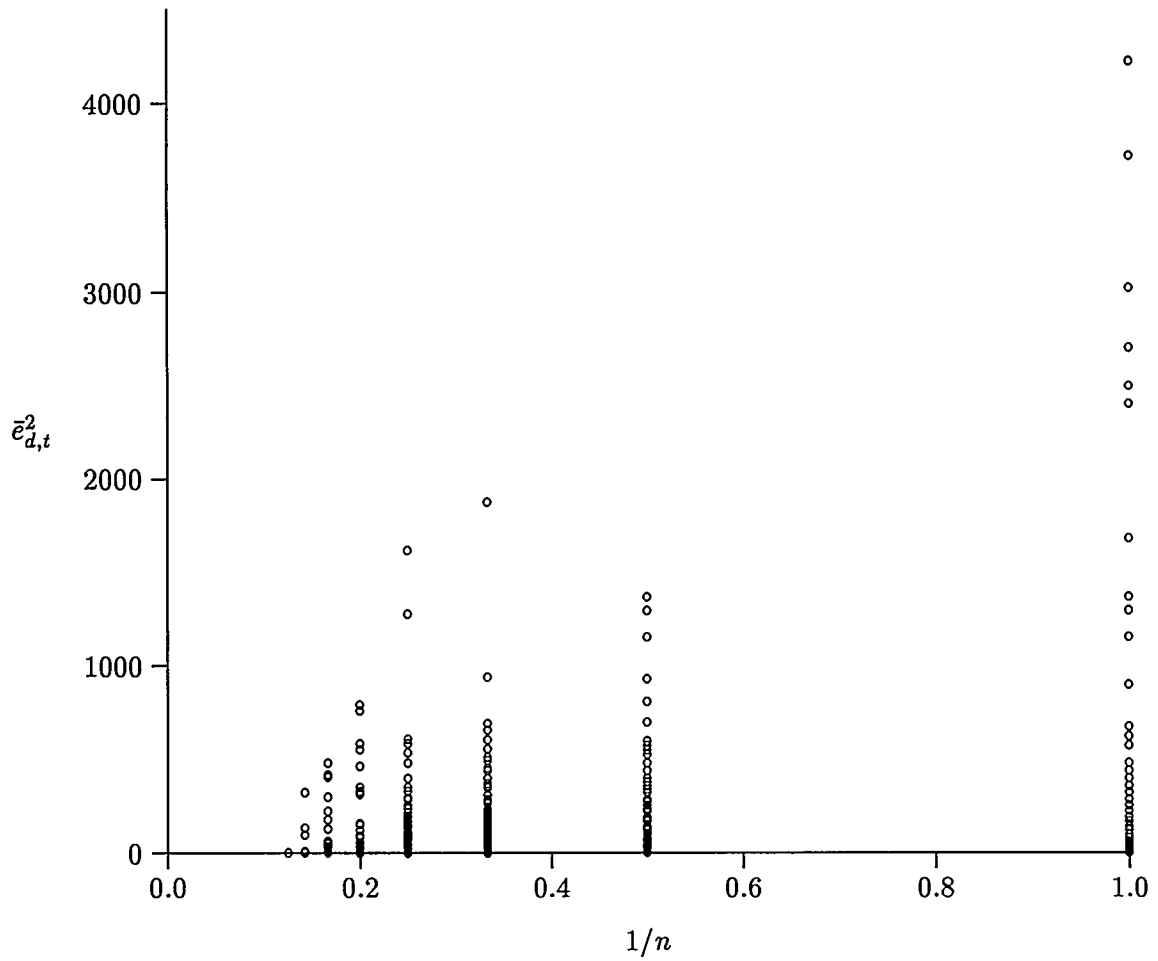

Figure 7: Plot of $[\bar{e}_{d,t}]^2$ against $1/n$ for Link 1 during the Peak Period

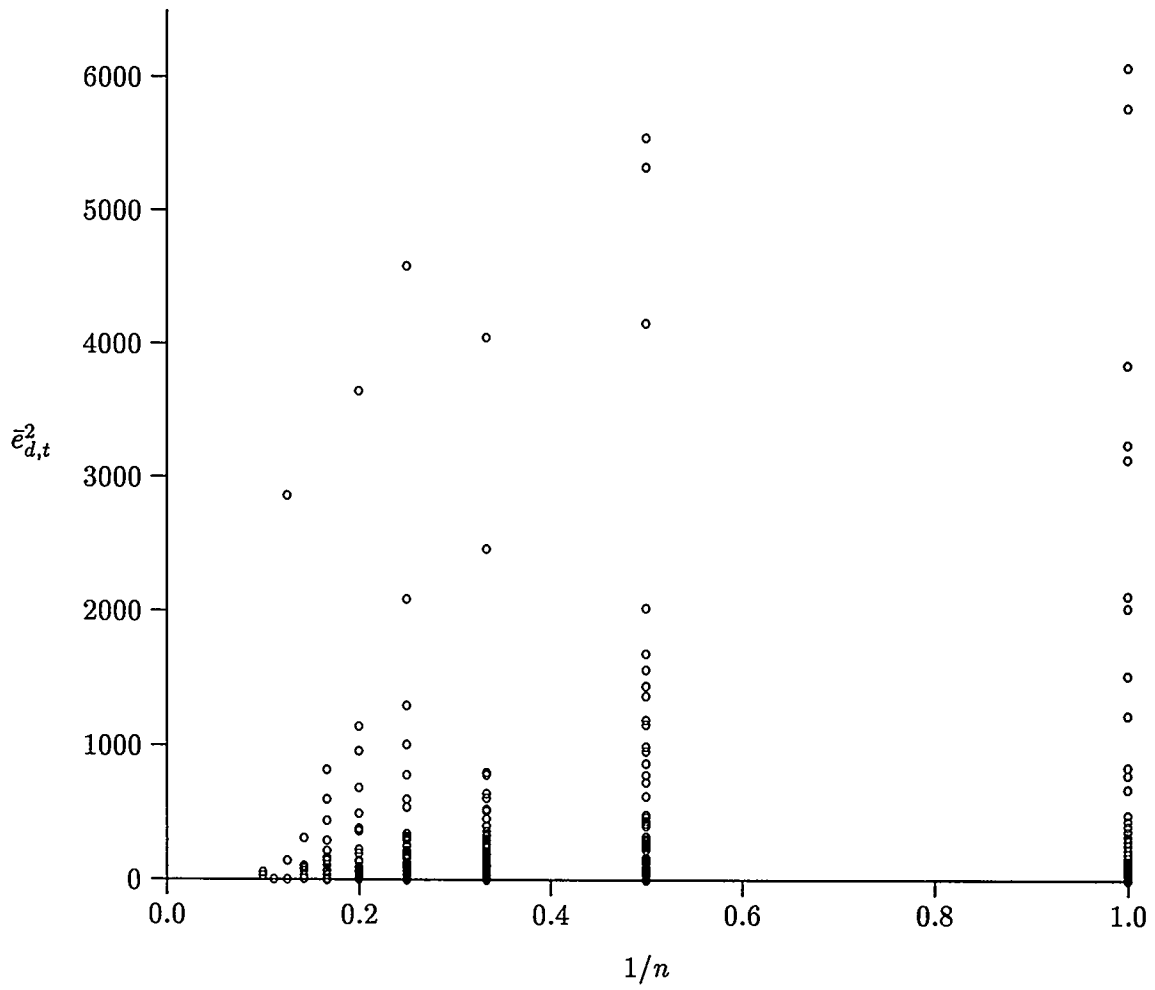

Figure 8: Plot of $[\bar{e}_{d,t}]^2$ against $1/n$ for Link 11 during the Peak Period

α_d and β_t being common to different $\bar{e}_{d,t}$'s. The model, (2), is based on a mathematical identity. Therefore, there would appear to be no significant violations to the Gauss-Markov Conditions *under the hypothesis*, save for the presence of outliers. The presence of outliers would only tend to increase rather than decrease standard errors. If there is any slight heteroscedasticity left that too, by violating the minimum variance property of least squares estimates, would only tend to raise standard errors. Thus the test we conducted (using t -values to examine the size of the intercept) is an appropriate test, albeit perhaps lacking somewhat in power; that is, we would err on the side of accepting rather than rejecting H . Notice further that, given the large sample sizes, it is appropriate to assume that the estimate of the intercept is approximately normally distributed (Sen and Srivastava, 1990, Ch. 5), although the dependent variable values might not be — they are in fact highly skewed.

Column 6 in Tables 4 and 5 shows the t -values for $\hat{\nu}$ for various links for the peak and off-peak periods respectively. The $\hat{\nu}$ symbol denotes an estimate ($\hat{\eta}$ is an estimate of η), s.e. and t refer to standard errors and t -values respectively. The two tables also give $\hat{\nu}$, $\hat{\eta} - \nu$, and their standard errors and $\hat{\eta}$ along with the total sample size (obs.) and \bar{x}_ℓ , or the mean travel times for all links ℓ that were analyzed. A description of the data has been given in Section 3 and the time interval over which means were computed was 5 minutes. It is easily seen that all estimates of ν are positive and are significant at the 5% level or better, with the exception of Links 5, 6 and 8 in the peak period and Links 2, 5 and 6 in the off-peak period.

| Link | mean (\bar{x}_ℓ) | obs. | $\hat{\nu}$ | s.e. | t | $\hat{\eta} - \nu$ | s.e. | t | $\hat{\eta}$ |
|------|-------------------------|------|-------------|--------|------|--------------------|--------|------|--------------|
| 1 | 69.73 | 1233 | 102.77 | 26.04 | 3.95 | 246.88 | 73.17 | 3.37 | 349.65 |
| 2 | 59.29 | 1242 | 93.36 | 40.06 | 2.33 | 518.30 | 119.67 | 4.33 | 611.66 |
| 31 | 64.90 | 886 | 228.16 | 71.25 | 3.20 | 553.98 | 171.28 | 3.23 | 782.14 |
| 32 | 39.14 | 308 | 113.69 | 44.56 | 2.55 | 55.95 | 79.93 | 0.70 | 169.64 |
| 4 | 114.47 | 320 | 440.99 | 162.43 | 2.72 | 298.12 | 236.11 | 1.26 | 739.11 |
| 5 | 38.20 | 327 | 36.55 | 61.15 | 0.60 | 44.97 | 87.53 | 0.51 | 81.70 |
| 6 | 53.63 | 321 | 100.13 | 58.03 | 1.73 | 124.56 | 121.29 | 1.03 | 224.69 |
| 7 | 196.3 | 309 | 966.11 | 248.69 | 3.89 | 24.26 | 332.95 | 0.07 | 990.37 |
| 8 | 85.36 | 297 | 30.50 | 94.02 | 0.32 | 804.41 | 209.61 | 3.89 | 834.91 |
| 9 | 167.98 | 355 | 1082.86 | 228.85 | 4.73 | 172.97 | 325.73 | 0.53 | 1255.83 |
| 10 | 81.38 | 1253 | 102.98 | 50.18 | 2.05 | 479.67 | 91.35 | 5.26 | 582.66 |
| 11 | 47.55 | 1275 | 122.25 | 45.96 | 2.67 | 279.56 | 82.75 | 3.38 | 401.91 |
| 12 | 88.83 | 1260 | 250.41 | 46.20 | 5.42 | 249.33 | 82.94 | 3.01 | 499.74 |

Table 4: Estimates from Day/Time-of-Day Model for the Peak Period

The situation in Link 5 can be easily explained; it is a very lightly traveled link with no traffic control. On this link, a vehicle rarely affects the travel time of another vehicle. Link 6 is also very lightly traveled but has a stop sign. Of course, for neither was there

| Link | mean (\bar{x}_ℓ) | obs. | $\hat{\nu}$ | s.e. | t | $\widehat{\eta - \nu}$ | s.e. | t | $\hat{\eta}$ |
|------|-------------------------|------|-------------|-------|------|------------------------|--------|------|--------------|
| 1 | 69.86 | 1746 | 56.98 | 20.98 | 2.72 | 287.83 | 63.74 | 4.52 | 344.81 |
| 2 | 47.40 | 1728 | 31.23 | 28.56 | 1.09 | 615.80 | 88.62 | 6.95 | 647.03 |
| 31 | 60.43 | 627 | 205.93 | 64.70 | 3.18 | 412.19 | 113.45 | 3.63 | 618.12 |
| 32 | 31.56 | 1028 | 39.61 | 19.15 | 2.07 | 140.42 | 53.38 | 2.63 | 180.03 |
| 4 | 93.08 | 1048 | 346.53 | 74.06 | 4.68 | 258.09 | 126.69 | 2.04 | 604.62 |
| 5 | 36.29 | 1063 | 20.81 | 47.22 | 0.44 | 56.24 | 94.46 | 0.60 | 77.05 |
| 6 | 44.78 | 1059 | 11.15 | 6.24 | 1.79 | 57.62 | 17.18 | 3.35 | 68.77 |
| 7 | 96.22 | 1068 | 516.91 | 91.08 | 5.68 | 494.69 | 177.27 | 2.79 | 1011.60 |
| 8 | 58.59 | 961 | 77.73 | 29.42 | 2.64 | 163.45 | 48.51 | 3.37 | 241.17 |
| 9 | 65.72 | 1042 | 277.22 | 58.40 | 4.75 | 282.80 | 114.66 | 2.47 | 561.00 |
| 10 | 58.86 | 1680 | 203.63 | 53.27 | 3.82 | 623.81 | 89.47 | 6.97 | 827.44 |
| 11 | 50.98 | 1712 | 148.54 | 43.27 | 3.43 | 546.22 | 75.20 | 7.26 | 694.76 |
| 12 | 75.18 | 1588 | 159.53 | 31.35 | 5.09 | 170.94 | 55.32 | 3.09 | 330.47 |

Table 5: Estimates from Day/Time-of-Day Model for the Off-Peak Period

any effect from traffic signals. Link 8 is more difficult to explain, particularly because the lack of significance occurs only for the peak. However, a partial explanation is that all the probe vehicles that were the source of the data entered the link via a right turn. Because traffic during the peak period on the major westbound route is heavy, most vehicles would execute the turn on green, and would, therefore, often encounter sparse traffic until they reached the end of the link. This is particularly the case during the peak when progression was excellent.

With the exception of the links and time periods mentioned above, the t -values were always large indicating that the hypothesis of no correlation and of $\nu = 0$ may be rejected for them.

4.3 Estimation of Parameters

The least squares procedure we used above to test for lack of correlations is also a reasonable method for estimating η and ν . One advantage of treating average covariances and variances as parameters in a regression model is that we do not have to directly measure them. Direct measurement would be complicated because, owing to the presence of traffic signals, the mean link travel time at any instant would be very difficult to obtain without using additional information, such as on signal timing.

4.4 Implications of Dependence

Although, we have examined only a small number of links, we would expect (2) with $\nu > 0$ to be true for well-traveled, signalized links in general. In this section, we draw

some implications of this result for probe-based ATIS. Figures 9 and 10 show the relationship between the standard error of mean link travel times *computed using model (2) and parameter values from Table 4*, for Links 32 and 11, against n , the number of probes during a five-minute interval. Thus, while figures comparable to Figures 9 and 10 would vary from link to link, we would expect these figures to illustrate curves of generally the same shape provided the links were well-traveled and signalized.

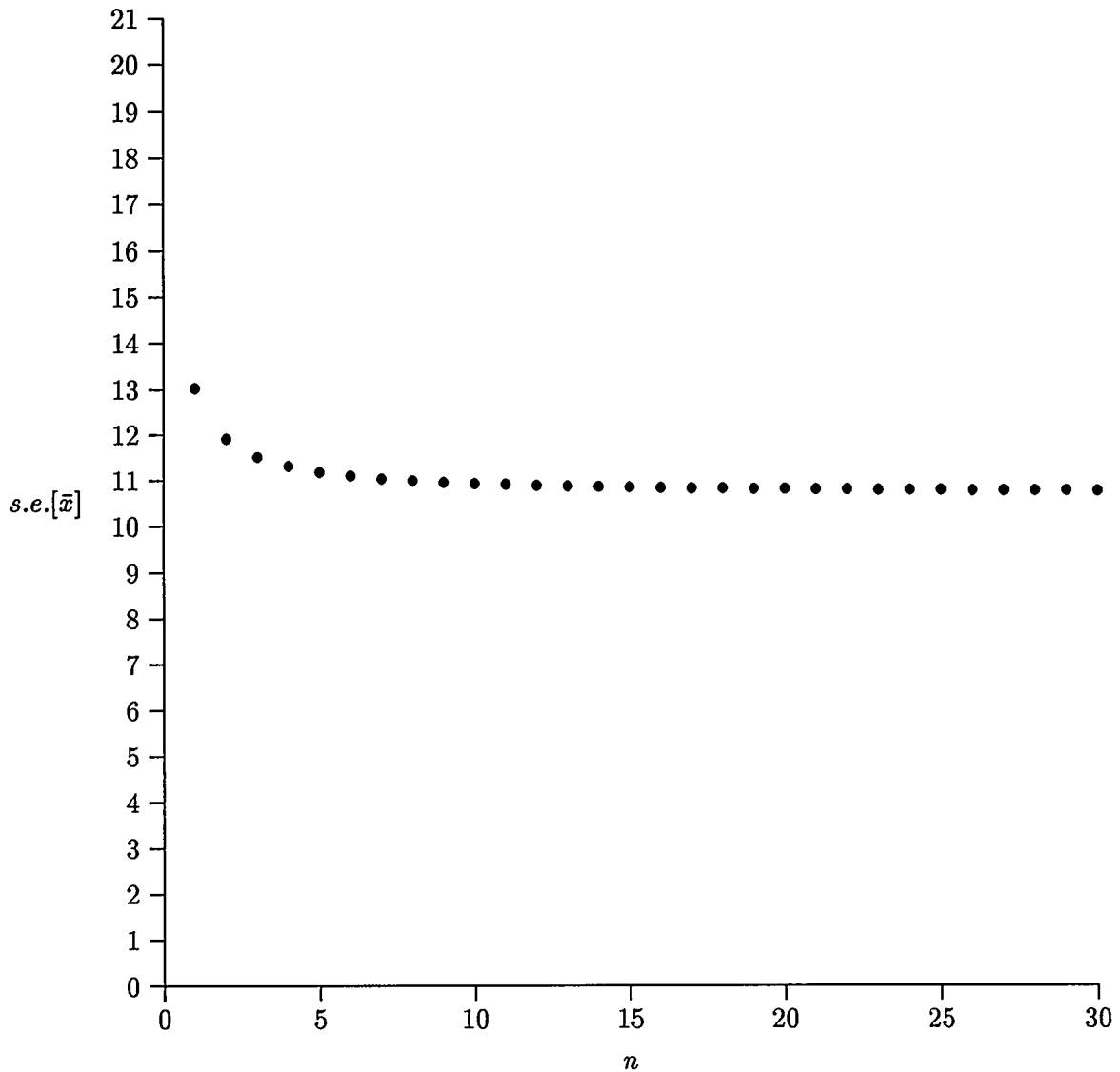

Figure 9: Relationship between Standard Error $s.e.[\bar{x}]$ and Frequency n of Probes on Link 32 during the Peak Period Estimated from the Model $[\bar{e}_{d,t}]^2 = \nu + \gamma_1[1/n_{d,t}] + \epsilon_{d,t}$.

Notice from Figure 9, the plot for Link 32 during the peak period, that the points flatten out rapidly with increasing n . For $n \rightarrow \infty$, the standard errors would approach $\hat{\nu} = 10.66$. Therefore, if we are willing to accept a roughly 10% increase in standard

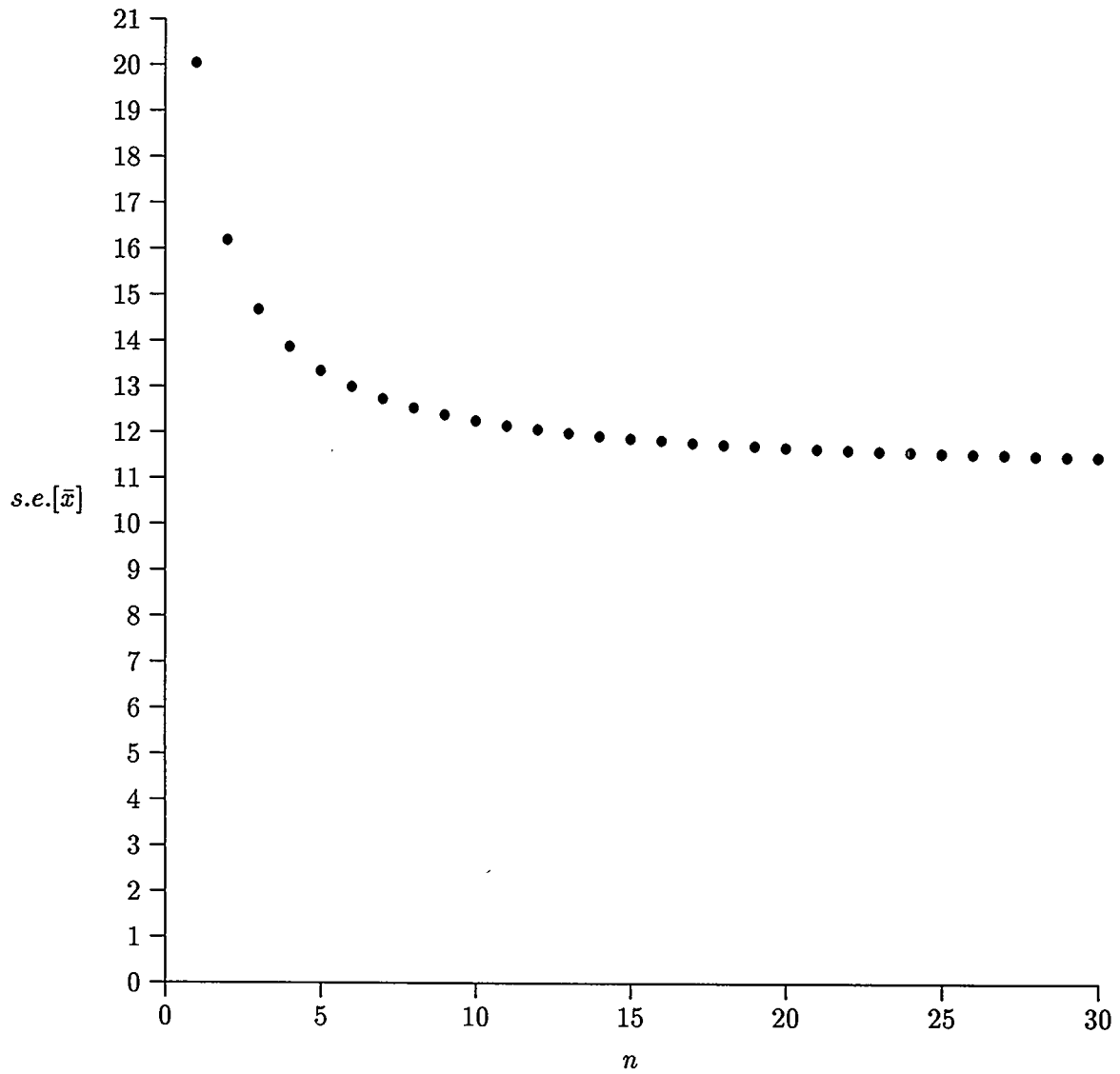

Figure 10: Relationship between Standard Error $s.e.[\bar{x}]$ and Frequency n of Probes on Link 11 during the Peak Period Estimated from the Model $[\bar{e}_{d,t}]^2 = \nu + \gamma_1[1/n_{d,t}] + \epsilon_{d,t}$.

errors, we could get by with two observations and if we accept a 20% increase in standard error, even a single observation could suffice.

The rate of flattening depends on the relative sizes of $\hat{\nu}$ and $\hat{\eta} - \hat{\nu}$ and we chose Link 32 to illustrate a case where $\hat{\eta}$ was somewhat close to $\hat{\nu}$. Consider now the case of Link 11 for the peak period (Figure 10). Here the ratio of $\hat{\eta} - \hat{\nu}$ to $\hat{\nu}$ is considerably larger than for Link 32. For Link 11, then, a 10% increase in standard errors is achieved with about 10 observations, and a 20% increase with 5 observations.

Usually highly-traveled links have high correlations between travel times of vehicles. Therefore, under situations of high congestion the sample sizes required would be smaller. Thus, ATIS would be of major benefit in recurrent congestion situations because, when congestion is low, travel times would tend to be closer to historic averages (suitably conditioned on day-of-week and time-of-day considerations) and, when congestion is high, even low deployment levels would usually achieve acceptable probe frequencies because of higher overall traffic volume. For example, suppose we have a moderately-high congestion level represented by 1500 vehicles per hour for a two-lane arterial or 125 vehicles per five-minute period. Then a 1% deployment level would give us 1 vehicle per five minutes on average and a 5% deployment would give us 6 vehicles.

These observations coupled with the discussion in Section 3 lead us to the statements we made at the end of the Introduction.

- the deployment level originally planned for full deployment would have been adequate to provide fairly good dynamic information.
- deployment levels four or five times higher than originally planned would yield significantly better information, above this level information would continue to improve with deployment level but the improvements would be slight.

Two additional conclusions also emerge:

- The variance of mean link travel times remains quite far from zero no matter how many probes traverse the link.
- After deployment of a certain number of probes per unit time, additional probes do not decrease the variance very much.

High levels of deployment would of course be necessary to cover and monitor a wider area of the network. However, the second conclusion above suggests that very high levels of market penetration by probe-based ATIS may be unnecessary in order to improve estimates of link travel times. Methods must therefore be devised which take the variance of link travel times explicitly into account in any sample size computation for probe-based systems.

5 Recommendations

From the discussion above and that of Section 3, we make the following judgment: the deployment level originally planned for full deployment would have been adequate to provide fairly good dynamic travel-time information. Deployment levels four or five times higher would yield significantly better information. Above that, while information quality would continue to improve with deployment, the improvements would be slight.

In future efforts involving probe-based ATIS, we strongly recommend that

- Exit times of probes from each link traversed be accurately noted
- Times at which phase changes occur at each traffic signal be made available to travel time prediction algorithm.

Although, since no such data were available, numerical estimates cannot be provided, we expect that with these additions extremely high quality travel-time estimates can be produced, even with relatively low deployment levels.

References

Hicks, J. E., D. E. Boyce and A. Sen (1992), *Static Network Equilibrium Models and Analyses for the Design of Dynamic Route Guidance Systems*, A Technical Report in support of the design phase of the ADVANCE project

Sen, A. and M. Srivastava (1990), *Regression Analysis: Theory, Methods and Applications*, New York: Springer-Verlag.

Boyce, D. E., A. M. Kirson and J. L. Schofer (1994), *ADVANCE — The Illinois Navigation and Route Guidance Demonstration Program*, in *Advanced Technology for Road Transport*, Ian Catling (ed.), Artech House, Boston.

Thakuriah, P. and A. Sen (forthcoming), *An Investigation into the Quality of Information given by an Advanced Traveler-Information System*, *ASCE Transportation Journal*.

APPENDIX G

ADVANCE

**Advanced Driver and Vehicle
Advisory Navigation Concept**

Traffic Related Functions
Evaluation Report (7 of 7)
Documents # 8460.00

CONTAINS:

| | |
|--|--------------------------|
| Base Data and Static Profile Evaluation Report | -- Document # 8460-01.01 |
| Data Screening Evaluation Report | -- Document # 8460-02.02 |
| Quality of Probe Reports Evaluation Report | -- Document # 8460-03.01 |
| Travel Time Prediction and Performance of Probe and Detector Data Evaluation Report | -- Document # 8460-04.01 |
| Detector Travel Time Conversion and Fusion of Probe and Detector Data Evaluation Report | -- Document # 8460-05.01 |
| Frequency of Probe Reports Evaluation Report | -- Document # 8460-06.01 |
| Relationships among Travel Times Evaluation Report | -- Document # 8460-07.02 |

Prepared by
University of Illinois-Chicago
Urban Transportation Center

DISCLAIMER

This report was prepared by a contractor for
Argonne National Laboratory
and is published as it was received.

ADVANCE Evaluation

Relationships among Travel Times

Ashish Sen, Siim Sööt, Helen Condie,
Xiaoqun Zhu and Xin Tian

URBAN TRANSPORTATION CENTER
University of Illinois at Chicago
1033 West Van Buren Street
Suite 700 South
Chicago, Illinois 60607

October 1996

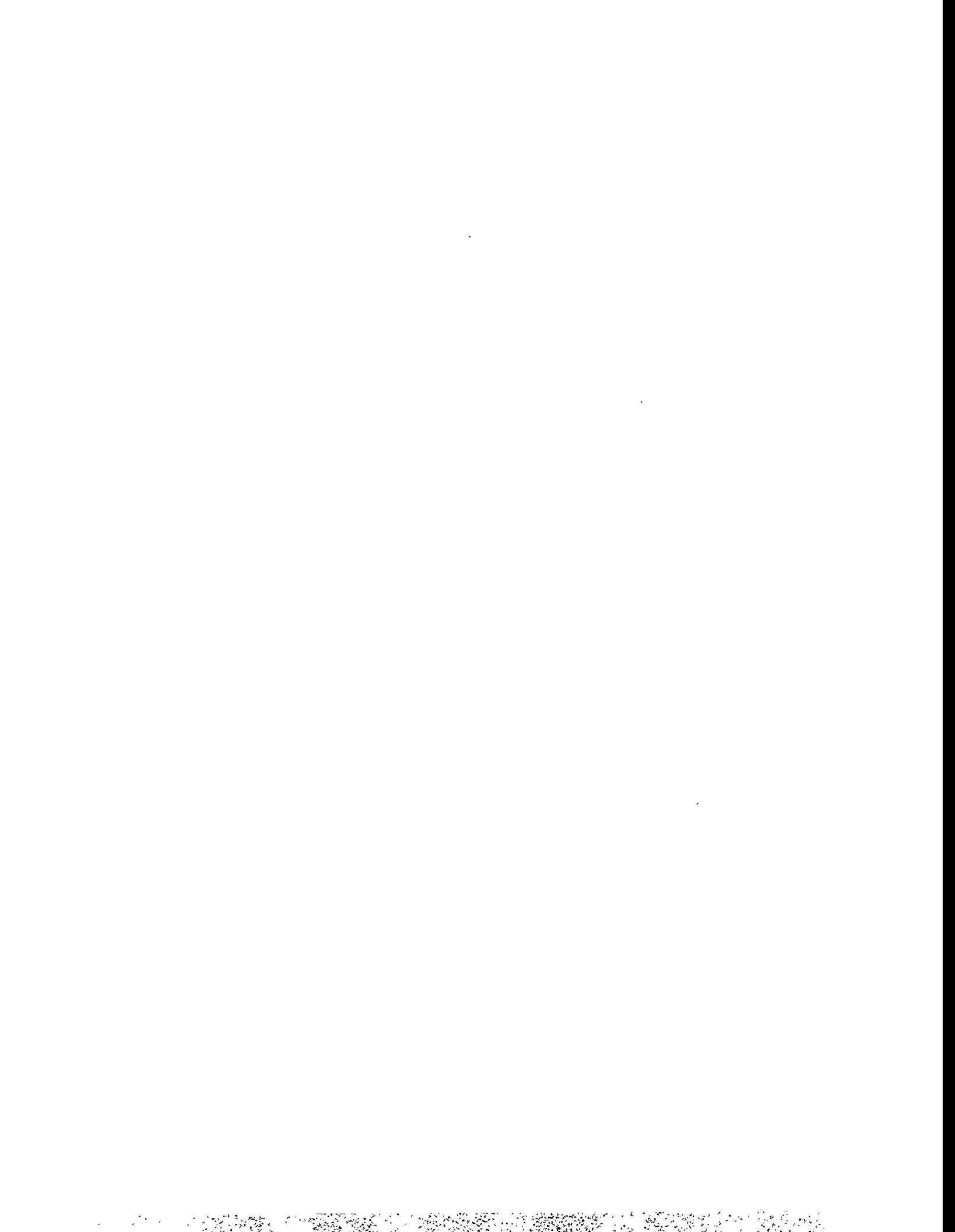

Executive Summary

In a dynamic route-guidance system, through movements will likely be by far the most prevalent movements at intersections. Therefore it will be useful to predict left and right-turning travel times from known through-movement travel times on a segment of road. The purpose of the *Relationships among Travel Times* task is to determine a method for predicting turning-movement travel times from through-movement travel times.

Data were collected over a three-week period in the summer of 1995 on a series of specially-designed study routes, focusing on one target link on the section of Dundee Road between Elmhurst Road and Wheeling Road in Wheeling, Illinois. Two types of comparison between turning-movement and through-movement travel times were made. First we evaluated the existing ADVANCE procedure of adding empirically-derived constants to through-movement travel times to predict turning-movement travel times. Then we built a series of regression models to determine if a more complex relationship between left-turn and through-movement travel times exists.

Without additional information on signal timings, adding a constant to through-movement travel times is generally a fairly accurate method of predicting turning-movement travel times. However the accuracy of this model varies over the links and turning movements that were analyzed. The regression models using through-movement travel times and intersection-approach traffic volumes did not produce forecasts of left-turn travel times that were much better than those obtained using the method of adding a constant to the through-movement travel times.

However when signal timing information was input to the regression model a better prediction of left-turn travel time could be made. This indicates that signal timing is the most effective predictor of turning-movement travel times. Without prior knowledge of signal timings it is extremely difficult to accurately predict turning-movement travel times from known through-movement travel times and detector traffic volumes on intersection approaches.

Contents

| | |
|---|-----------|
| Executive Summary | i |
| 1 Introduction | 1 |
| 2 Turning-Relationships Procedure | 1 |
| 3 Study Area and Data Collection | 2 |
| 3.1 Study Links | 2 |
| 3.2 Data-Collection Design | 2 |
| 3.3 Driving Schedule | 5 |
| 3.4 Data Analysis | 5 |
| 4 Results: Comparison of Travel Times | 8 |
| 4.1 Dundee Road Target Links | 8 |
| 4.1.1 Link A: Westbound | 8 |
| 4.1.2 Link a: Eastbound | 11 |
| 4.2 Other Links on the Study Routes | 13 |
| 4.2.1 Other Links, Off-Peak Period | 13 |
| 4.2.2 Other Links, Peak period | 13 |
| 4.3 Regression Models to Predict Left-Turn Travel Time on Target Link A . . | 17 |
| 4.3.1 Regression Model 1: Using Through-Movement Travel Time | 17 |
| 4.3.2 Regression Model 2: Using Detector Traffic Volumes | 18 |
| 4.3.3 Regression Model 3: Using Signal Information | 19 |
| 4.3.4 Comments on the Regression Models | 20 |
| 5 Conclusion | 21 |
| Glossary | 22 |

List of Figures

| | | |
|---|---|----|
| 1 | Probe Data Collection: Turning-Relationships Links | 3 |
| 2 | Example of a Turning-Relationships Data-Collection Route | 4 |
| 3 | Link A: Intersection-Approach Configuration | 8 |
| 4 | Relationships among Travel Times: Target Link A | 10 |
| 5 | Relationships among Travel Times: Target Link a | 12 |
| 6 | Relationships among Travel Times on Non-Target Links: Off-Peak Period . | 14 |
| 7 | Relationships among Travel Times on Non-Target Links: Peak Period . . . | 15 |
| 8 | Left-Turn Travel Time by Through-Movement Travel Time: Target Link A | 18 |

List of Tables

| | | |
|---|---|----|
| 1 | Relationships among Travel Times: Sample Sizes for Data Analysis | 7 |
| 2 | Summary Data for Difference between Turning and Through-Movement Travel Time: Link A | 9 |
| 3 | Summary Data for Difference between Turning and Through-Movement Travel Time: Link a | 11 |
| 4 | Summary Data for Difference between Turning and Through-Movement Travel Time: Other Links on the Study Route | 16 |
| 5 | Analysis of Variance and Parameter Estimates: Regression Model 1 | 17 |
| 6 | Analysis of Variance and Parameter Estimates: Regression Model 2 | 19 |
| 7 | Regression Model 3: Signal Information | 20 |
| 8 | Analysis of Variance and Parameter Estimates: Regression Model 3 | 21 |



1 Introduction

Travel-time data for through movement links will most likely be the most prevalent of all types of travel-time data because through movements are generally executed more frequently than turns. Hence, deriving travel times for turning-movement links from links with the same base segment with a through movement is desirable for dynamic travel-time prediction. For example, if a through-movement link experiences heavy congestion as determined from corresponding probe reports, then the adjacent left-turning movement, in all likelihood, is also experiencing heavy congestion. However, without a left-turn probe report, TTP (Travel-Time Prediction) will predict the time as being equivalent to the SP (Static Profile) estimate. If the relationship between through and left-turn travel times can be determined a more accurate prediction, based on the left-turn travel time, can be made.

The ADVANCE design included a provision for estimating travel times for turning movements based on probe reports for through movements. This task requires travel-time data from relevant combinations of links (e.g., through and left-turn travel times from the same segments at the same times). The procedure, described in detail in Section 2, consists of adding a constant to the link travel-time estimate for the through movement to obtain a corresponding travel time for the left or right turn. This report presents the results of the evaluation of this procedure. The evaluation actually consists of two parts. In the first part we assess if the constants added to through-movement travel times are of an appropriate magnitude. The second part of our evaluation attempts to answer the question of whether non-constant quantities would have provided more accurate predictions of turning-movement travel times.

The results from the evaluation may be summarized as follows: there does not seem to be a simple formula which would be much of an improvement over a constant. Promising results were obtained only when we input signal-timing data to a regression model. The constants used by ADVANCE are reasonably accurate but could perhaps be slightly improved in a straightforward manner.

2 Turning-Relationships Procedure

Before probe observations were available for static-profile updating, travel-time estimates were obtained using the Network Flow Model (NFM) described in detail in Sen *et al.* (1996). For a given link ℓ and time interval i the travel time for a through movement given by this model is $t_{\ell,i}$ and the corresponding time for a left turn is $l_{\ell,i}$.

Suppose for any time interval i and day d , the through-movement link travel time is $T_{\ell,i,d}$ and the corresponding link travel time for a left turn is $L_{\ell,i,d}$. The time intervals for dynamic forecasts are five minutes long, while the NFM estimates are for much longer intervals (the off-peak interval covers the period from 1:00 pm to 4:00 pm and the peak period lasts from 4:00 pm to 6:00 pm). However, each dynamic-estimate interval

is contained within an NFM interval. Therefore, corresponding to a dynamic-estimate interval is an NFM interval and a corresponding NFM estimate (the Base Data, or BD estimate) for each link and movement. The intervals i referred to above are the five-minute dynamic-estimate intervals.

The ADVANCE procedure estimates left-turn travel times when no probe reports for left turns are available as follows:

$$L_{\ell,i,d} = T_{\ell,i,d} + l_{\ell,i} - t_{\ell,i} \quad (1)$$

In this way ADVANCE uses historic data on the difference between the left-turn and through-movement travel times on a pair of links sharing the same base segment to predict a left-turn travel time from a through-movement travel time within the same five-minute interval. The formula for right turns is similar. We evaluate the appropriateness of this method in Section 4, where the actual differences between turning and through-movement travel times are presented and compared to the NFM Base Data (BD) estimates.

3 Study Area and Data Collection

During the summer of 1995 an average of twelve vehicles per day were driven four days a week over an eleven-week period. During this time almost 60,000 miles were driven to produce over 50,000 link reports within a confined study area. The ADVANCE evaluation project comprises a number of tasks. The 11-week data-collection period yielded probe data for the analysis of several subtasks. Data for the turning-relationships task was gathered at the end of the data-collection period.

3.1 Study Links

During the last three weeks of data collection in the Dundee Road study area the vehicles were used to evaluate turning-movement travel-time predictions. In this case each driver was given a set of randomly-drawn routes, to be driven in sequence, which covered the links shown on Figure 1. The target section of Dundee Road identified in the Evaluation Test Plan (Links A and a) is clearly shown. On Link H/h the drivers were permitted to stop and study the rest of the routes they had been assigned to drive. Data collection on the turning-relationships routes generally yielded more than 1500 usable MNA reports per day. Over half of these reports are on Dundee Road (the links labelled A, a, B, b, E and e) and are also used in deriving static profiles.

3.2 Data-Collection Design

The data-collection effort for this evaluation task had to be carefully designed for several reasons:

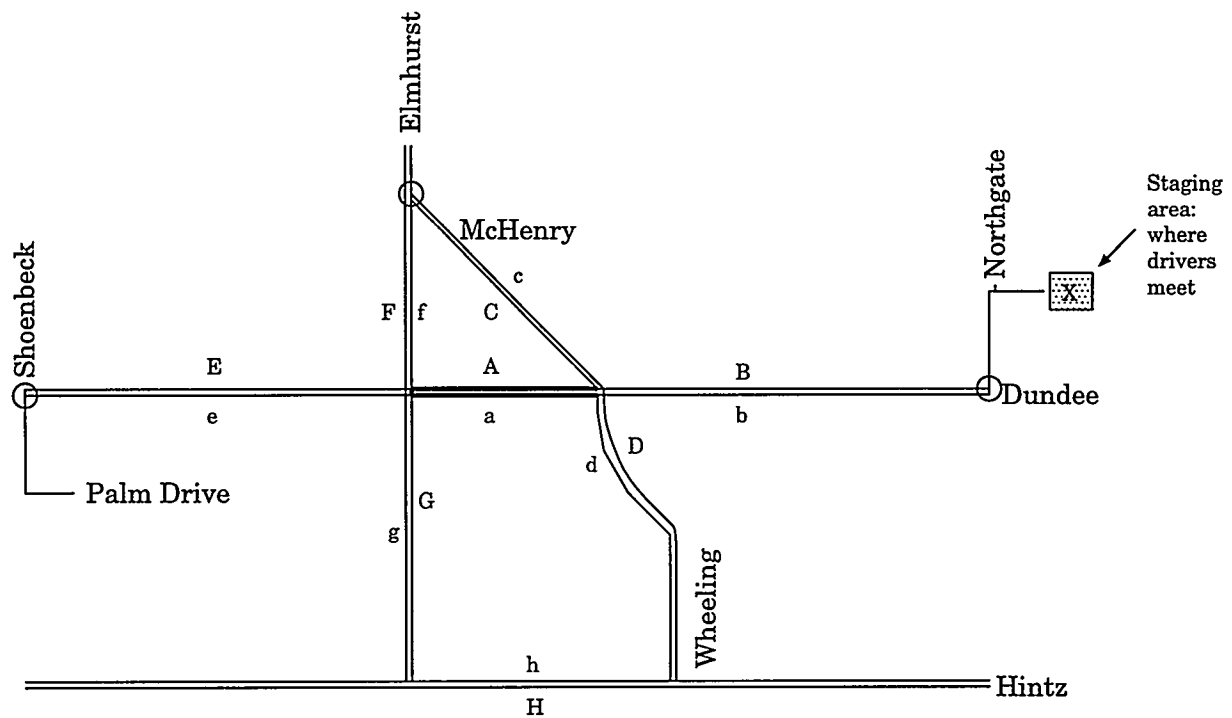

Figure 1: Probe Data Collection: Turning-Relationships Links

- In order to compute the differences in travel times between vehicles traveling straight ahead through an intersection and vehicles executing a turn, it was necessary to have at least one vehicle executing each movement. However, it would be difficult to have drivers of the probe vehicles drive ‘normally’ and yet travel the through-movement and turning links simultaneously. Besides it is the difference in averages that is of concern here.
- It was necessary to cover several different links and different types of intersections.
- It was necessary to avoid biases due to driver styles by having, for example, the same driver always executing a left turn or always executing a through movement.
- It was necessary to avoid biases due to previous movements executed.

Therefore, a randomized design was constructed. A set of routes was constructed and drivers were asked to follow an assigned sequence of these routes. The method of constructing the routes is detailed below [we acknowledge the help given by Jerry Sacks and Alan Karr of the National Institute of Statistical Sciences]:

1. Each route started from one of 3 fixed points (at Northgate, Palm Drive or at Hintz Road - see Figure 1).
2. At each intersection the movement to be executed was determined randomly. Probabilities were assigned for each movement. For example, the probabilities for a probe

a great deal of experience with the vehicles and were familiar with the purpose of the data collection. Also, as we generally used a smaller number of vehicles for this exercise, we needed fewer drivers and were able to select those drivers who appeared to be most capable of following the detailed instructions for this particular data-collection exercise.

3.3 Driving Schedule

Data were collected on the turning-relationships study routes Monday through Thursday from July 24th to August 10th, and on one Friday, August 4. At the beginning of each day of data collection, a twelve-noon briefing was held at the ADVANCE office in Schaumburg. At this time the drivers were assigned vehicles and they left the office at approximately 12:30 pm. Data were collected by probe vehicles driven on the study routes between 1:00 pm and 7:00 pm with breaks as described below.

On each day of data collection a field manager was present at the staging area. The field manager ensured that vehicles were driven on the study route at satisfactory headways and instructed drivers when to take breaks.

The drivers were given a ten-minute break at approximately 2:00 pm and another one from approximately 6:00 pm to 6:10 pm. Each driver took his or her break at a slightly different time, since each was dispatched by the field manager to the break area as they arrived at the staging area. During breaks each probe vehicle was inactive for more than ten minutes as time was lost off-route and also because the vehicle and MNA needed warm-up time. A longer break occurred from 3:30 pm to 4:00 pm. After this break, during the two-hour peak period from 4:00 pm to 6:00 pm, the drivers operated their vehicles without scheduled breaks.

3.4 Data Analysis

Vehicles were driven on the turning-relationships routes as described above. For the purposes of our analysis of the relationships among travel times we required travel-time data for those 5-minute intervals where travel times are available for the two movements (i.e., a turning and a through movement) which are the subject of our comparison. For example, on target link A on Dundee Road we analyzed data from every five-minute interval for which travel times are available for the left turn and through movement (396 5-minute periods) and for the right turn and through movement (374 5-minute periods).

Table 1 shows the sample sizes (i.e., the number of 5-minute intervals) from Target Link A, Link a and all other links where turning and through-movement travel times were available for comparison. The naming system used in this table (and throughout the report) is that the upstream and downstream links — as shown on Figure 1 — for the turning or through movement are given. For example, the movement identified as Af is the right turn from Dundee Road to Elmhurst Road. It can be seen from this table that in addition to the target links on Dundee Road we gathered useful data from McHenry Road, Wheeling Road and Elmhurst Road. All the links for which sample sizes are shown

in Table 1 were used in our evaluation of the constants added to through-movement travel times to predict turning-movement travel times. The regression analysis was performed to predict the travel time for the left turn from Dundee Road to Elmhurst Road (Link Ag).

Table 1: Relationships among Travel Times: Sample Sizes for Data Analysis

| Link | | # 5-minute intervals |
|-----------------------------|----------|----------------------|
| Dundee Road westbound: | | |
| Ag-AE (left turn-through) | Off-Peak | 191 |
| | Peak | 205 |
| Af-AE (right turn-through) | Off-Peak | 183 |
| | Peak | 191 |
| Dundee Road eastbound: | | |
| ac-ab (left turn-through) | Off-Peak | 103 |
| | Peak | 113 |
| ad-ab (right turn-through) | Off-Peak | 79 |
| | Peak | 89 |
| McHenry Road: | | |
| Cb-Cd (left turn-through) | Off-Peak | 7 |
| | Peak | 8 |
| Ca-Cd (right turn-through) | Off-Peak | 19 |
| | Peak | 20 |
| Wheeling Road: | | |
| DA-Dc (left turn-through) | Off-Peak | 33 |
| | Peak | 32 |
| Db-Dc (right turn-through) | Off-Peak | 15 |
| | Peak | 15 |
| Dundee Road (eastbound): | | |
| ef-ea (left turn-through) | Off-Peak | 8 |
| | Peak | — |
| eg-ea (right turn-through) | Off-Peak | 7 |
| | Peak | — |
| Elmhurst Road (southbound): | | |
| Fa-Fg (left turn-through) | Off-Peak | 17 |
| | Peak | 14 |
| Elmhurst Road (northbound): | | |
| Ga-Gf (right turn-through) | Off-Peak | 9 |
| | Peak | 12 |

4 Results: Comparison of Travel Times

4.1 Dundee Road Target Links

As described in the Evaluation Test Plan, the turning-relationships analysis will focus on the target links on the section of Dundee Road between Wheeling/McHenry and Elmhurst (see Figure 1). Link A is the westbound link and Link a is the eastbound link.

4.1.1 Link A: Westbound

Link A on Dundee Road is a westbound link terminating at the intersection with Elmhurst Road. Vehicles may proceed straight ahead along Dundee Road, or they may turn left or right onto Elmhurst Road. This section of Dundee Road has two lanes, however at the approach to the intersection with Elmhurst there is a dedicated left-turn lane. Left-turning traffic receives a left-turn green arrow at the beginning of or preceding the green phase for Link A. Right-turning traffic may proceed through the intersection on red; right-turning vehicles do not however have a dedicated lane. The configuration of Link A is illustrated in Figure 3.

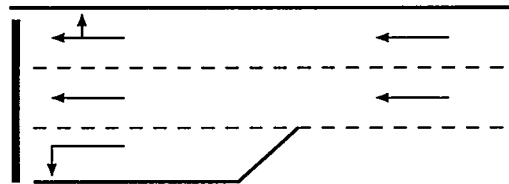

Figure 3: Link A: Intersection-Approach Configuration

Relationships among travel times on through movements and left and right turns on Link A, westbound on Dundee Road, are shown as histograms in Figure 4. Each histogram presents the frequency of each observed difference (in seconds) between the turning-movement travel time and the through-movement travel time. Superimposed on each histogram is an arrow indicating the value of the difference between the BD estimate (from the NFM) for the turning-movement travel time and the BD estimate for the through-movement travel time. Table 2 presents summary statistics for each turning/through-movement travel-time difference. Note that the mean of each difference is not particularly relevant to the comparison of the BD estimates with observed travel-time differences. Each travel-time difference is computed by subtracting the mean of all through-movement travel times from the mean of all turning-movement travel times in a given five-minute interval. We are more concerned therefore with how often (i.e. during how many five-minute intervals) the travel time difference obtained from the NFM (i.e., the BD estimate) is replicated by the travel time difference reported by probe vehicles. This is the information presented in the frequency histograms.

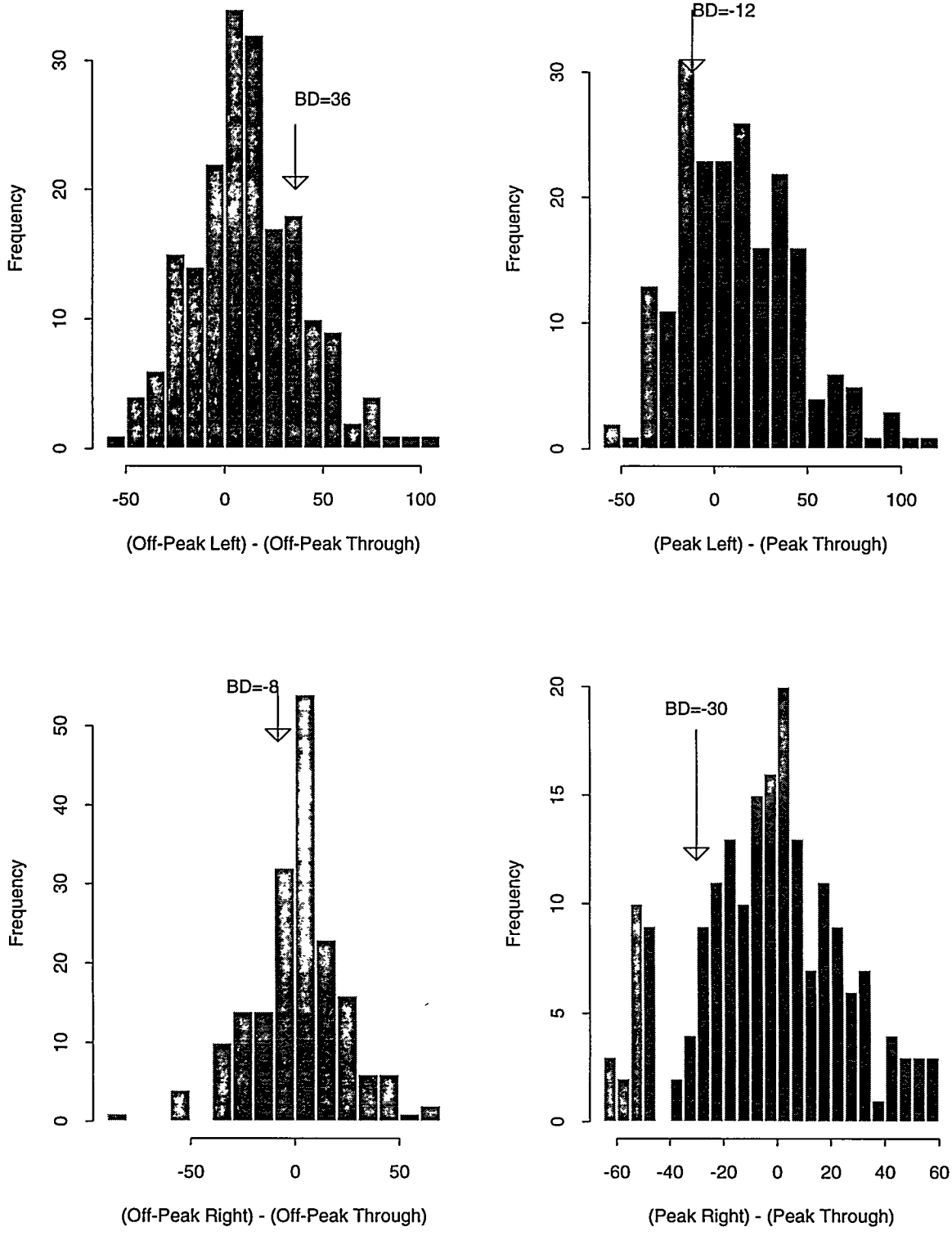

Figure 4: Relationships among Travel Times: Target Link A

Note: The x-axis of each histogram shows the difference (in seconds) between the turning-movement travel time and the through-movement travel time. The y-axis of each histogram shows the frequency (number of five-minute intervals) for which each difference in through-movement and turning-movement travel times was observed.

Table 2: Summary Data for Difference between Turning and Through-Movement Travel Time: Link A

| Travel Time Difference | | Mean | Median | variance | s.d. | BD Estimate |
|------------------------|----------|------|--------|----------|------|-------------|
| (left) - (through) | Off-Peak | 11.6 | 10.0 | 774.0 | 27.8 | 36 |
| | Peak | 12.3 | 10.0 | 1008.6 | 31.8 | -12 |
| (right) - (through) | Off-Peak | 2.0 | 3.2 | 495.2 | 22.3 | -8 |
| | Peak | -3.6 | -2.5 | 759.3 | 27.6 | -30 |

The value of the BD estimate for the difference between the turning-movement travel time and the through-movement travel time is close to the mode of the frequency of this difference in two of the four histograms on Figure 4, those relating to the peak-period left turn and the off-peak right turn. For the peak-period left turn, 88 of the 205 observed travel-time differences are within +/- 20 seconds of the BD estimate, -12. For the off-peak right turn 118 (65%) of the 183 observed travel-time differences are within +/- 20 seconds of the BD estimate of -8, and 55 are within +/- 10 seconds of the BD estimate.

The BD estimates are further from the modal value of the observed travel-time differences for the off-peak left turn and the peak period right turn. In both these cases the BD estimate differs by more than 20 seconds from the mode of the frequency of the observed difference. Based on the findings presented in Figure 4 few conclusions can be reached on whether the BD estimate more closely approximates the the difference between the through movement and left-turn or right-turn travel time, or is more accurate in the peak or off-peak periods.

4.1.2 Link a: Eastbound

Link a occupies the same segment of Dundee Road as Link A described above. Link a however is the eastbound link with traffic in the opposite direction to that on Link A. Link a terminates at the intersection of Dundee Road with Wheeling and McHenry Roads. Vehicles on Link a may proceed straight ahead along Dundee Road, they may turn left onto McHenry Road or they may turn right onto Wheeling Road. The configuration of Link a at this intersection is similar to that described for Link A above. Link a has two through-traffic lanes and a dedicated left-turning lane, left-turning traffic receives a green arrow at the start of or preceding the green phase.

The relationships among travel times on through movements and left and right turns on Link a, eastbound on Dundee Road, are shown as histograms in Figure 5. Again, summary statistics for each turning/through-movement travel-time difference are shown (Table 3).

The position of the arrows (for BD estimates) on the histograms in Figure 5 suggests that the BD estimates for turning movements are generally more accurate on this link than for the link described above (Link A, for which the sample size of 5-minute intervals was larger). Again the BD estimate for the left-turning movement in the peak period appears to be relatively accurate; 40 of the 113 probe-reported travel-time pairs in the peak period give a value for left-turn travel time minus through-movement travel time of +/- 20 seconds of the BD estimate. The BD estimate for the off-peak left turn is also relatively accurate; 59 of the 103 probe-reported travel-time differences are within +/- 20 seconds of the BD estimate.

The BD estimates for right-turning traffic (the estimate of zero indicates the right-turning travel time is not predicted to differ from that for the through movement) appear to be accurate with reference to the probe-reported travel time differences for right turns and through movements. In the off-peak 43 of the 79 travel-time differences are within +/- 20 seconds of the BD estimate, in the peak period 42 of the 89 travel-time differences are within +/- 20 seconds of the BD estimate. For Link a, the BD estimates are more accurate for the right-turning movement. However, the left turn is clearly the more interesting case.

Table 3: Summary Data for Difference between Turning and Through-Movement Travel Time: Link a

| Travel Time Difference | | Mean | Median | variance | s.d. | BD Estimate |
|------------------------|----------|------|--------|----------|------|-------------|
| (left) - (through) | Off-Peak | 22.7 | 17.5 | 1108.7 | 33.3 | 24 |
| | Peak | 41.7 | 42.5 | 1551.3 | 39.4 | 30 |
| (right) - (through) | Off-Peak | -0.6 | 0.0 | 758.7 | 27.5 | 0 |
| | Peak | 4.6 | 7.0 | 1519.8 | 39.0 | 0 |

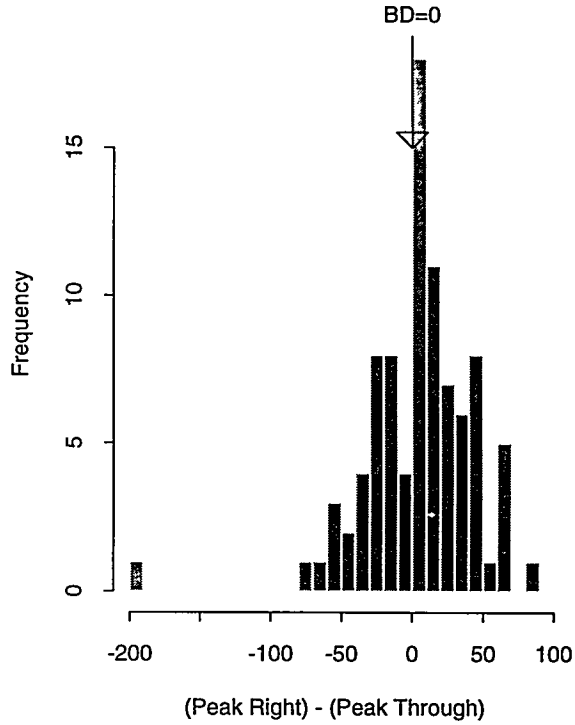
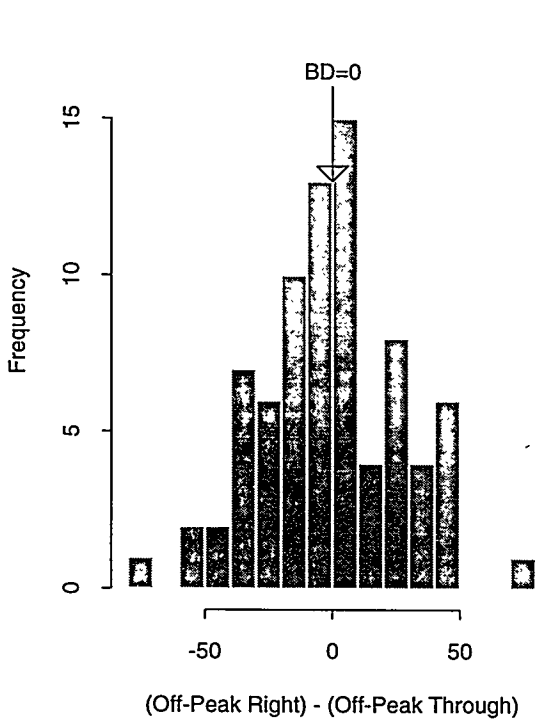
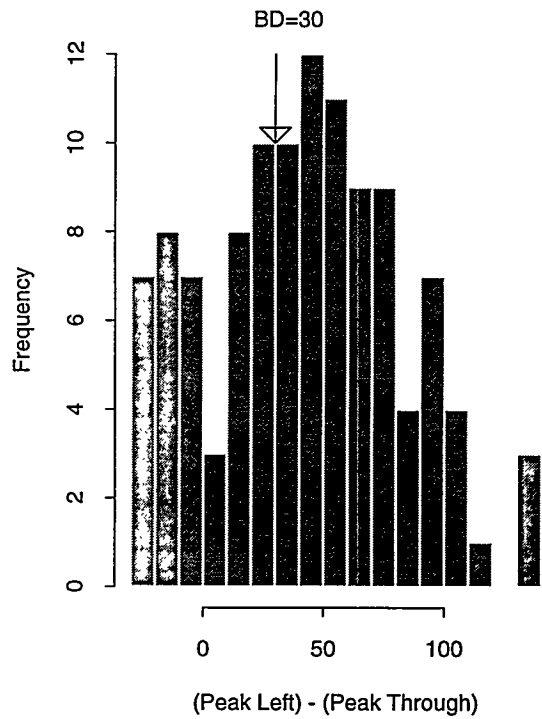
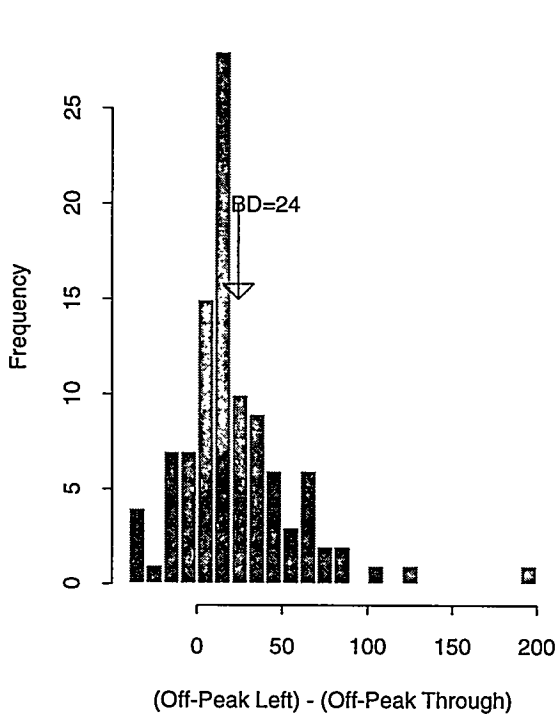

Figure 5: Relationships among Travel Times: Target Link a
 Note: The x-axis of each histogram shows the difference (in seconds) between the turning-movement travel time and the through-movement travel time. The y-axis of each histogram shows the frequency (number of five-minute intervals) for which each difference in through-movement and turning-movement travel times was observed.

4.2 Other Links on the Study Routes

Although the target links described above are the main focus of this analysis we have also analyzed turning relationships on other links on the study routes. In this case we have only analyzed those cases where, for 5-minute interval data, we have probe data for both turning and through movements to allow comparison of travel times.

4.2.1 Other Links, Off-Peak Period

In the off-peak period, eight road segments on the study routes were available for analysis in addition to the Dundee Road target links. The relationships among travel times on through movements and left and right turns on the non-target links for which data are available for the off-peak period are shown on the histograms in Figure 6. Some of the pairs of travel times analyzed had very few observations (Table 1) and therefore reveal little of use. However, where a reasonable number of 5-minute intervals were available for analysis, for example the left-turn/through-movement pair of links on Wheeling Road northbound [(Left Turn_DA)-(Through Movement_Dc)] for which thirty-three 5-minute periods were analyzed, the results of the analysis are similar to those presented for the Target Links, A and a. That is, there is general agreement but not absolute agreement between the BD estimate for the left-turn movement and the left-turn travel times experienced by the probes.

4.2.2 Other Links, Peak period

Fewer road segments (only six) were available for analysis in the peak period. The relationships among travel times on through movements and left and right turns on the non-target links for which data are available for the peak period are shown on the histograms in Figure 7. Again, there is a reasonable sample (thirty-two 5-minute periods) on the Wheeling Road northbound left-turn and through-movement pair (Left Turn_DA)-(Through Movement_Dc). The histogram for this pair of movements again shows close agreement between the BD estimates and probe-reported left-turn travel times. The right-turn and through-movements on McHenry Road southbound, (Right Turn_CA)-(Through Movement_Cd), also had a reasonable sample size (twenty 5-minute intervals) and also show good (but not exceptional) agreement between the BD estimate and probe travel times for the right turn.

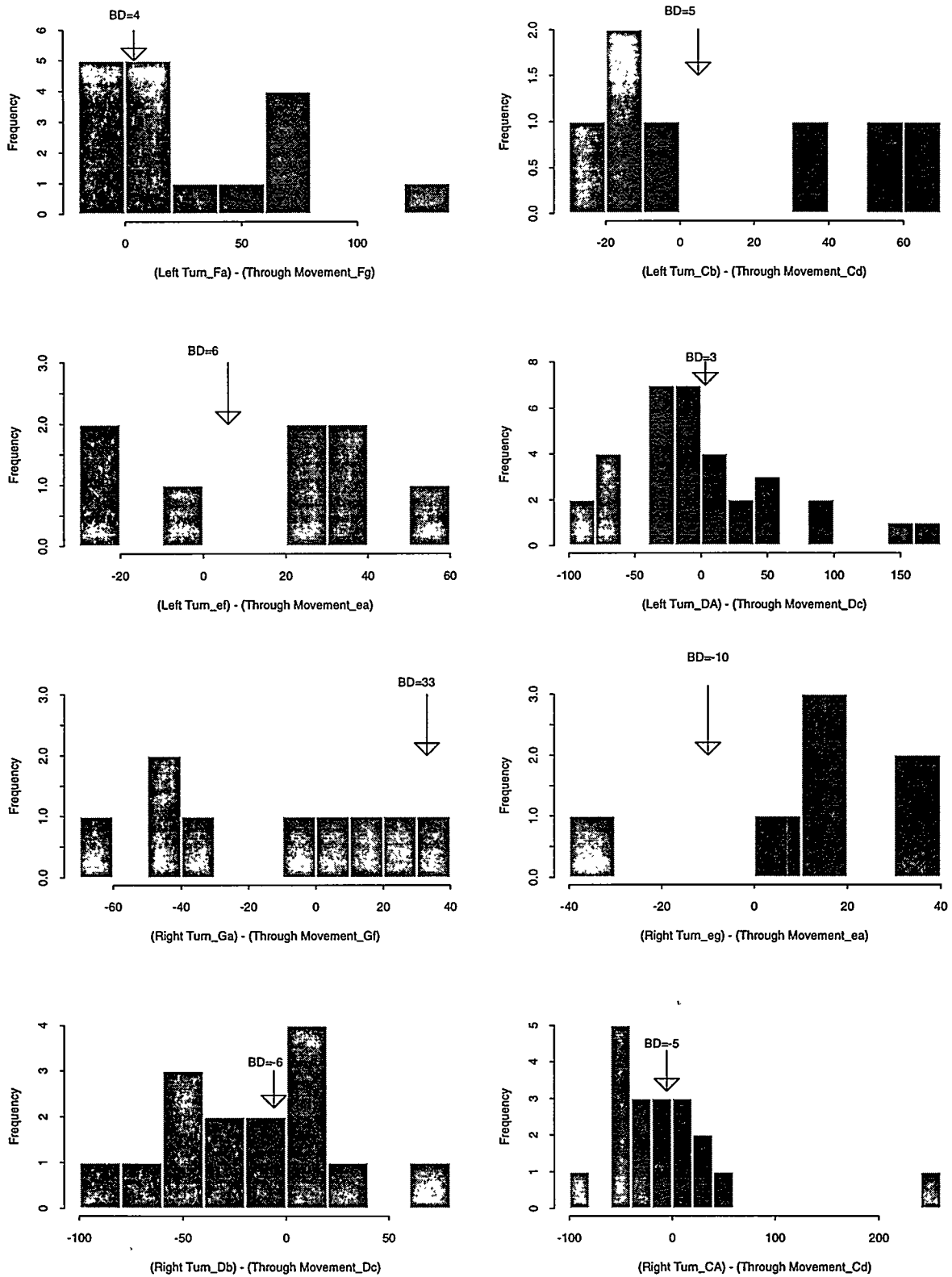

Figure 6: Relationships among Travel Times on Non-Target Links: Off-Peak Period
 Note: The x-axis of each histogram shows the difference (in seconds) between the turning-movement travel time and the through-movement travel time. The y-axis of each histogram shows the frequency (number of five-minute intervals) for which each difference in through-movement and turning-movement travel times was observed.

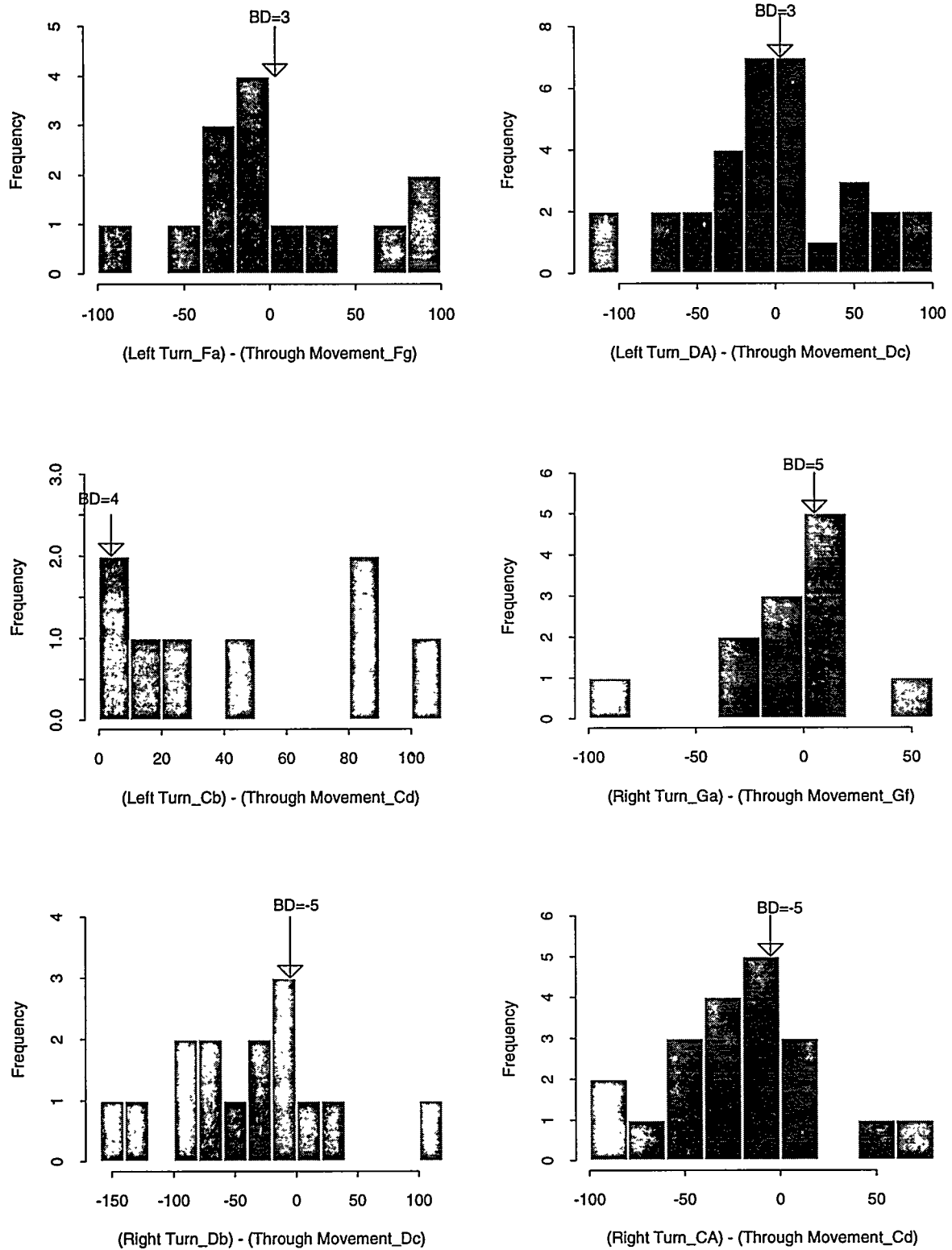

Figure 7: Relationships among Travel Times on Non-Target Links: Peak Period
 Note: The x-axis of each histogram shows the difference (in seconds) between the turning-movement travel time and the through-movement travel time. The y-axis of each histogram shows the frequency (number of five-minute intervals) for which each difference in through-movement and turning-movement travel times was observed.

Table 4: Summary Data for Difference between Turning and Through-Movement Travel Time: Other Links on the Study Route

| Travel Time Difference | | <i>n</i> = | Mean | Median | variance | s.d. | BD Estimate |
|---------------------------|----------|------------|-------|--------|----------|------|-------------|
| (left_Fa) - (through_Fg) | Off-Peak | 17 | 26.7 | 10.0 | 1784.6 | 42.2 | 4 |
| | Peak | 14 | 3.1 | -11.5 | 2773.4 | 52.7 | 3 |
| (left_Cb) - (through_Cd) | Off-Peak | 7 | 15.0 | -5.0 | 1303.3 | 36.1 | 5 |
| | Peak | 8 | 46.0 | 33.5 | 1744.9 | 41.8 | 4 |
| (left_ef) - (through_ea) | Off-Peak | 8 | 15.9 | 25.2 | 979.9 | 31.3 | 6 |
| | Peak | — | — | — | — | — | — |
| (left_da) - (through_dc) | Off-Peak | 33 | 2.3 | -9.0 | 3952.6 | 62.9 | 3 |
| | Peak | 32 | -1.9 | -2.3 | 2608.6 | 51.1 | 3 |
| | | | | | | | |
| (right_Ga) - (through_Gf) | Off-Peak | 9 | -12.7 | -1.0 | 1276.3 | 35.7 | 33 |
| | Peak | 12 | -7.2 | -1.3 | 1144.3 | 33.8 | 5 |
| (right_eg) - (through_ea) | Off-Peak | 7 | 13.9 | 18.0 | 621.0 | 24.9 | -10 |
| | Peak | — | — | — | — | — | — |
| (right_Db) - (through_Dc) | Off-Peak | 15 | -14.8 | -17.0 | 1806.5 | 42.5 | -6 |
| | Peak | 15 | -37.6 | -29.0 | 4154.2 | 64.5 | -5 |
| (right_CA) - (through_Cd) | Off-Peak | 19 | -2.4 | -17.0 | 5007.5 | 70.8 | -5 |
| | Peak | 20 | -22.2 | -20.2 | 1640.2 | 40.5 | -5 |

4.3 Regression Models to Predict Left-Turn Travel Time on Target Link A

The regression analysis was performed on the segment of the study route with the largest number of probe reports, Target Link A (see Table 1). The intersection of Dundee Road with Elmhurst Road has volume detectors on all approaches; five-minute aggregate detector volumes were used in the regression analysis.

In order to predict left-turn travel time we constructed three regression models with different inputs as the independent variables. In the first model we used only through-movement travel times as predictors. In the second model, in addition to through-movement travel times, we included traffic-volume data from the detectors on the four intersection approaches. Finally we used signal information in the regression model. The results from each regression analysis (performed using SAS) are presented below.

4.3.1 Regression Model 1: Using Through-Movement Travel Time

The analysis of variance table and parameter estimates from the regression performed to predict left-turn travel times on Link A from through-movement travel times on Link A are shown in Table 5. In this model the five-minute *mean* travel time for the through movement is used to predict each individual left-turn travel time.

Table 5: Analysis of Variance and Parameter Estimates: Regression Model 1

F -value 3.58
 Prob $> F$ 0.059

Root MSE 27.61
 R-square 0.0058

Parameter Estimates:

| Independent Variable | Parameter Estimate | Standard Error | T for H_0 : Parameter = 0 | Prob $> T $ |
|----------------------|--------------------|----------------|--------------------------------|--------------|
| Intercept | 59.56 | 3.26 | 18.25 | 0.0001 |
| $TT_{through}$ | 0.11 | 0.06 | 1.89 | 0.059 |

The critical value of F at the 1% level of significance with 1 and 609 degrees of freedom is 6.7. The F -value from this analysis is less than the critical F -value ($3.58 < 6.7$) therefore we cannot reject the hypothesis that the slope of the regression is zero at a 1% level of significance. Even at a 5% level of significance (critical value of $F = 3.85$) we cannot reject the hypothesis that the slope of the regression is zero, although the situation is more borderline now. However, because the residuals are very large and the regression

line is not a good fit for the data ($R^2 = 0.0058$), even the level of significance attained is largely due to a large sample size and it would be inadvisable to use the model for predictive purposes.

Figure 8 shows a plot of each left-turn travel time vs. the corresponding five-minute mean through-movement travel time (that is, the data used in the regression model). The figure also shows the best-fit regression line $\hat{y} = a + bx$, ($\hat{y} = 59.56 + 0.11x$). This plot confirms the poor fit of the regression.

As the R^2 illustrates, the predictive ability of this model is very slight. Indeed, the most significant term is the intercept which actually turns out to be the best prediction of left-turn travel time. This leads to the conclusion that a constant (e.g., obtained from the NFM or subsequent static-profile updates) added to the through-movement travel time would do about as well as this simple regression model in predicting left-turn travel times from known through-movement travel times.

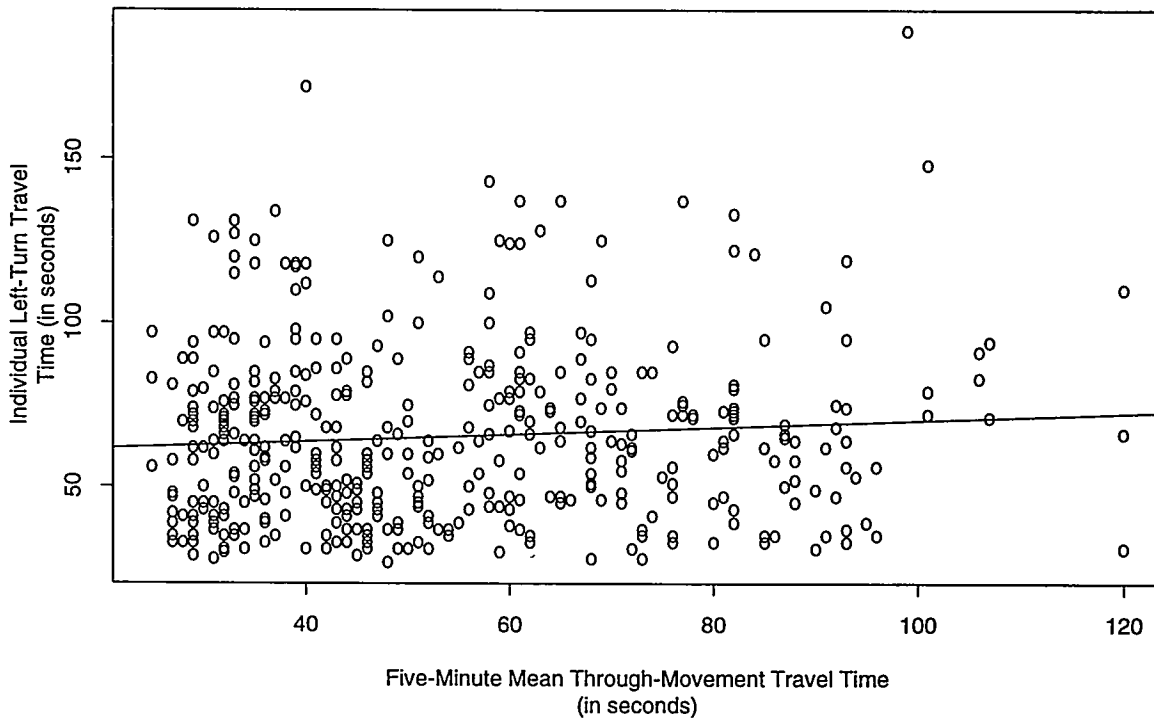

Figure 8: Left-Turn Travel Time by Through-Movement Travel Time: Target Link A

4.3.2 Regression Model 2: Using Detector Traffic Volumes

In order to improve on the results obtained from the first regression model, the second regression model includes data on through-traffic, cross-traffic and opposing-traffic volumes to predict left-turn travel times. The variables used to predict left-turn travel time on Link A in the second regression model are 5-minute mean through-movement travel time

on Link A and five-minute aggregated detector volumes on the four approaches to the intersection — Dundee Road eastbound, Dundee Road westbound (i.e. Link A), Elmhurst Road southbound and Elmhurst Road northbound.

Table 6: Analysis of Variance and Parameter Estimates: Regression Model 2

F -value 5.26
 Prob $> F$ 0.0001

Root MSE 25.83
 R-square 0.054

Parameter Estimates:

| Independent Variable | Parameter Estimate | Standard Error | T for H_0 : Parameter = 0 | Prob $> T $ |
|----------------------|--------------------|----------------|--------------------------------|--------------|
| Intercept | 27.14 | 9.86 | 2.75 | 0.0062 |
| $TT_{through}$ | 0.015 | 0.061 | 0.25 | 0.80 |
| $VOL_{eastbound}$ | 0.13 | 0.155 | 0.84 | 0.40 |
| $VOL_{westbound}$ | 0.17 | 0.082 | 2.03 | 0.04 |
| $VOL_{northbound}$ | 0.02 | 0.095 | 0.21 | 0.84 |
| $VOL_{southbound}$ | 0.27 | 0.143 | 1.86 | 0.06 |

This regression model offers little improvement over the previous model. The critical value of F at the 1% level of significance with 5 and 464 degrees of freedom is 3.03. The F -value from this analysis is greater than the critical F -value ($5.26 > 3.03$) therefore we must reject the hypothesis that the independent variables collectively have no effect on the dependent variable. However the residuals are still very large and the regression is not a good fit for the data. The value of R^2 ($R^2 = 0.054$) is somewhat higher than in the previous model but, as in the previous model, indicates a poor fit.

In this way, it is not desirable to predict the left-turn travel time on Link A from through-movement travel times and detector traffic volumes on the four intersection approaches. The inclusion of traffic volumes does not noticeably improve the predictive ability of the model.

4.3.3 Regression Model 3: Using Signal Information

During the turning-relationships data-collection exercise signal phasing and timing data were gathered. Observers noted the timing of all signal changes on Link A, for example, the change from red to green with green arrow. Using the time stamp on each probe report we were able to determine the time at which each probe vehicle passed through the

intersection of Dundee Road and Elmhurst. By matching these times with the manually-collected signal-timing data we noted the signal received by each vehicle passing through the intersection: red with green arrow, green *with* green arrow, or green *without* green arrow. Again we are indebted to NISS, who conducted this data-collection exercise.

In an attempt to find a good predictive model for left-turn travel time on Link A we constructed a regression model using through-movement travel times on Link A and the signal information described above. The signal information input to the model is in the form of dummy variables indicating the signal received by left-turning and through traffic (see Table 7).

Table 7: Regression Model 3: Signal Information

| Dummy Variable Name | Signal Aspect | S_{left} | $S_{through}$ | Travel Time Comparison |
|-----------------------|----------------------------------|------------|---------------|------------------------|
| S_{left} | red with green arrow | 1 | 0 | $TT_l < TT_t$ |
| $S_{left}S_{through}$ | green <i>with</i> green arrow | 1 | 1 | $TT_l = TT_t$ |
| $S_{through}$ | green <i>without</i> green arrow | 0 | 1 | $TT_l > TT_t$ |

S_{left} is the signal received by left-turning traffic

$S_{through}$ is the signal received by through traffic

TT_l is the left-turn travel time

TT_t is the through-movement travel time

The analysis of variance table and parameter estimates from the regression model constructed to predict left-turn travel times on Link A from through-movement travel times on Link A and the signal information described above are shown in Table 8. The value of R^2 ($R^2 = 0.54$) indicates a better fit of the regression.

While the through-movement travel times and five-minute aggregated detector traffic volumes do not enhance the predictive ability of using a constant to predict left-turn travel times, the use of signal timings yields a promising model.

4.3.4 Comments on the Regression Models

The results of the regression analyses performed for Link A indicate that using known through-movement travel times and intersection-approach traffic volumes is not useful in predicting left-turn travel times. A good prediction can be made when signal timing is known. However, as described above, this information was not available to us through the ADVANCE design; it had to be gathered manually. The manually-collected signal-timing data allowed us to construct a fairly simple regression model with promising results in the prediction of left-turn travel times. These results are not entirely surprising given that the signals are demand actuated. We therefore recommend that any future attempt to

Table 8: Analysis of Variance and Parameter Estimates: Regression Model 3

F -value 210.0
 Prob > F 0.0001

Root MSE 17.77
 R-square 0.54

Parameter Estimates

| Independent Variable | Parameter Estimate | Standard Error | T for H_0 : Parameter = 0 | Prob > T |
|-----------------------|--------------------|----------------|--------------------------------|-----------|
| Intercept | 29.56 | 2.63 | 11.2 | 0.0001 |
| $TT_{through}$ | 0.58 | 0.04 | 13.3 | 0.0001 |
| S_{left} | -23.65 | 1.40 | -16.9 | 0.0001 |
| $S_{left}S_{through}$ | -5.66 | 1.05 | -5.42 | 0.0001 |
| $S_{through}$ | 29.31 | 1.19 | 24.6 | 0.0001 |

predict turning-movement travel times from known through-movement travel times for a dynamic route-guidance system should use signal-timing data.

5 Conclusion

The analysis presented shows that the BD estimates for turning-movement travel times based on adding a constant to through-movement travel times are relatively accurate when compared to the turning-movement travel times experienced by probe vehicles. A future analysis of the relationships among turning movements should compare probe-reported travel times to static-profile updates [see Sen *et al.* (1996)] instead of BD estimates.

Our analysis of regression models constructed using left-turn travel times as the dependent variable and through-movement travel times and intersection-approach detector volumes as independent variables suggests that little is gained from the presence of these variables as compared to using a constant alone. However when signal-timing data is used as input to a regression model to predict left-turn travel times a more accurate prediction can be made. We therefore conclude and recommend that signal-timing information should be made available in future attempts to predict turning-movement travel times.

References

Mathes M. and Sen A. (1995) *Static Estimates of Travel Times in ADVANCE: Release 2.0 SPU Algorithm Report and Detail Design Document (#8600)*, ADVANCE Working Papers Series, Number 49, Urban Transportation Center, University of Illinois, Chicago.

Sen A., Condie H., Sheffey A., Xian T. and Zhu X. (1996) *ADVANCE Evaluation: Base Data and Static Profile*, Urban Transportation Center, University of Illinois, Chicago.

Urban Transportation Center (1995) *Relationships among Travel Times: Evaluation Test Plan*, University of Illinois, Chicago.

Glossary

Base Data (BD)/Base Data Estimates - travel-time predictions for specific links at specific times as derived from the NFM.

Network Flow Model (NFM) - the model developed by the TRF group based upon the contents of the *ADVANCE* Network Representation (ANR). The network flow model analyzes the ANR to produce link travel times and link flows by time period and day type.

Off-Peak - that portion of the day considered to have lighter traffic flow, defined in the study as 1:00 pm–4:00 pm.

Peak - that portion of the day considered to have heavier traffic flow, defined in the study as 4:00 pm–6:00 pm.

Static Profile (SP) - static information of the roadway link including day type, link ID and average travel times for a specific time period.

Static Profile Updating (SPU) - the revision of previous Static Profile travel times for links, during specific time periods, using information gathered from probe reports and processed through the SP algorithm.

Traffic Information Center (TIC) - Consisting of the hardware, software, a centralized facility and operations personnel. It communicates to and from probe vehicles and external systems.

Traffic Related Functions (TRF) - Subsystem consisting of data fusion, vehicle dynamics, incident detection and travel-time prediction algorithms.

Travel Time Prediction (TTP) - An algorithm used in the prediction at the TIC of future short term travel times on links to develop future adjustments to the static profiles.

APPENDIX H

ADVANCE

**Advanced Driver and Vehicle
Advisory Navigation Concept**

Evaluation of Arterial Probe Vehicle,
Fixed Detector and Expressway Fixed Detector
Incident Detection Algorithm
Evaluation Report
Document # 8461.01

Prepared by
Northwestern University Transportation Center

DISCLAIMER

This report was prepared by a contractor for
Argonne National Laboratory
and is published as it was received.

ADVANCE

Advance Driver and Vehicle
Advisory Navigation Concept

EVALUATION OF ARTERIAL PROBE VEHICLE, FIXED DETECTOR AND EXPRESSWAY FIXED DETECTOR INCIDENT DETECTION ALGORITHM

by

Frank S. Koppelman
Chieh-hua Wen
Wei-hsin Lin
Tsia-shiou Peng

Northwestern University
Transportation Center
Evanston, Illinois 60208

ADVANCE Project Document #8461.01

FINAL REPORT

September 24, 1996

Executive Summary

The incident detection component of *ADVANCE* was developed to provide real time information about the presence of incidents and their location with the expectation that such information will be valuable to local drivers, the primary users of *ADVANCE* who are familiar with the network and have some knowledge of expected travel times under "normal conditions". Effective identification of incidents and provision of relevant information to drivers will substantially enhance the effectiveness of dynamic route guidance. This report describes the procedures and results of testing the effectiveness of arterial probe vehicle and fixed detector incident detection methods implemented in *ADVANCE* and expressway fixed detector incident detection methods considered for but not implemented in *ADVANCE*.

The *ADVANCE* incident detection system for arterial roads uses fixed detectors which provide occupancy and volume data, probe vehicles which provide link traversal data and anecdotal descriptions of events which are likely to impact traffic flow on arterial roads. For the purpose of evaluation, the anecdotal data provided by Northwest Central Dispatch (NWCD) is adopted as representing the true incident conditions of roadways in the portion of the *ADVANCE* area which is within the emergency service jurisdictions supported by NWCD. The evaluation of both fixed detector and probe vehicle algorithms is undertaken by measuring the extent to which each of these algorithms is able to identify incidents reported by NWCD and the extent to which it reports the presence of incidents which are not confirmed by NWCD.

The arterial fixed detector algorithm implemented in *ADVANCE* identified seven of 141 incidents reported during a two month period, while also reporting nine false alarms; the mean

time to detect the detected incidents was approximately five minutes after the first report received by local emergency services through Northwest Central Dispatch. A modified algorithm which included standardized versions of volume deviation and occupancy deviation increased the number of detections to 29 with no false alarms and reduced the mean time to detect.

The arterial probe vehicle algorithm implemented in *ADVANCE* was evaluated for algorithms based on a single probe report and on multiple probe reports. The evaluation indicates that probe vehicle incident detection should be based on the use of multiple reports to avoid the potential for numerous false alarms based on unusual readings from a single vehicle caused by reasons other than disruptions in traffic flow. The algorithm based on the use of three sequential probe reports identified six of eleven incidents, for which sequences of three reports were available, without any false alarms. An alternative algorithm which changed the specification by the addition of congestion distance deviation improved the results to detect nine of nine incidents which included suitable data for estimation without generating any false alarms.

These results indicate substantial potential for the development of arterial incident detection algorithms based on volume and occupancy data from fixed detectors and link traversal data from probe vehicles. Further development of this potential would require additional testing in a variety of traffic situations.

Evaluation of a limited implementation of an expressway incident detection algorithm resulted in incident detection and false alarm performance worse than that obtained in the development context. This result raises questions about the use of previously estimated expressway incident detection algorithms without new estimation in the application area.

Table of Contents

| | |
|---|-----|
| Executive Summary | i |
| Table of Contents | iii |
| List of Figures | v |
| List of Tables | vi |
| 1. INTRODUCTION | 1 |
| 1.1 Objective of Incident Detection | 1 |
| 1.2 Multiple Data Sources for Arterial Incident Detection | 1 |
| 1.3 Expressway Incident Detection | 2 |
| 1.4 Purpose and Scope | 3 |
| 1.5 Report Structure | 4 |
| 2. FIXED DETECTOR ALGORITHM | 5 |
| 2.1 Overview | 5 |
| 2.1.1 Concept | 5 |
| 2.1.2 Initial Field Testing | 7 |
| 2.1.3 Fixed Detector Calibration | 9 |
| 2.2 Field Data Collection for Evaluation | 10 |
| 2.2.1 Data Description | 10 |
| 2.2.2 Preliminary Analysis | 12 |
| 2.3 Evaluation Results | 17 |
| 2.3.1 Overview | 17 |
| 2.3.2 Overall Evaluation | 18 |
| 2.3.3 Evaluation with Heuristic Screening Rules | 19 |
| 2.3.4 Evaluation by Time of Day | 20 |
| 2.3.5 Evaluation by Incident Type | 21 |
| 2.3.6 Summary | 21 |
| 2.4 Modifications of Arterial Fixed Detector Incident Detection Algorithm | 22 |
| 2.4.1 Re-calibration with Current Variables | 22 |
| 2.4.2 Extended Specification with Additional Variables | 24 |
| 2.4.3 Model Estimation for Peak and Off-Peak Periods | 28 |
| 2.4.4 Model Estimation for Major Incidents Only | 29 |
| 2.4.5 Summary | 31 |
| 2.5 Implementation of the Revised Algorithm | 31 |
| 2.6 Summary of Arterial Fixed Detector Evaluation | 36 |
| 3. PROBE VEHICLE ALGORITHM | 38 |
| 3.1 Overview | 38 |
| 3.2 Field Data Collection | 40 |

| | | |
|------------|---|----|
| 3.2.1 | Procedure for Data Collection | 40 |
| 3.2.2 | Data Description | 42 |
| 3.3 | Evaluation Results | 42 |
| 3.3.1 | Overview | 42 |
| 3.3.2 | Initial Evaluation Results | 44 |
| 3.4 | Modifications of Incident Detection Algorithms | 48 |
| 3.4.1 | Model Estimations Using Single Reports | 49 |
| 3.4.2 | Model Estimations Using Three Reports | 53 |
| 3.4.3 | Summary | 55 |
| 3.5 | Implementation of the Revised Algorithm | 56 |
| 3.6 | Summary of Arterial Probe Vehicle Evaluation | 60 |
| 4. | EXPRESSWAY ALGORITHM | 62 |
| 4.1 | Overview | 62 |
| 4.2 | Evaluation Data | 66 |
| 4.3 | Evaluation Results | 67 |
| 4.4 | Summary of Expressway Incident Detection | 71 |
| 5. | CONCLUSIONS | 72 |
| 5.1 | Evaluation of Arterial Incident Detection Using Fixed Detectors and Probe Vehicles | 72 |
| 5.1.1 | Evaluation of Arterial Fixed Detector Incident Detection Algorithm ... | 73 |
| 5.1.2 | Evaluation of Arterial Probe Vehicle Incident Detection Algorithm | 74 |
| 5.2 | Expressway Incident Detection | 75 |
| 5.3 | Conclusion | 76 |
| References | | 77 |
| Appendix A | | 79 |

List of Figures

| | | |
|------------|--|----|
| Figure 2.1 | Average Volume and Occupancy for Detectors at Wilke Rd, Westbound on Dundee | 14 |
| Figure 2.2 | Average Volume and Occupancy for Detectors at Buffalo Grove, Eastbound on Dundee | 14 |
| Figure 2.3 | Occupancy Deviation and Volume Deviation for Incident and Non-incident Cases | 16 |
| Figure 2.4 | Occupancy Deviation and Volume Deviation for Incident and Non-incident Cases with Increased Detail in Critical Range | 16 |
| Figure 2.5 | Incident and Non-incident, Standardized Occupancy Deviation by Standardized Volume Deviation | 27 |
| Figure 2.6 | Flow Diagram for the Arterial Fixed Detector Algorithm | 35 |
| Figure 3.1 | Effect of the Thresholds on the Single Report Model Results | 52 |
| Figure 3.2 | Effect of the Thresholds on the Three Report Model Results | 55 |
| Figure 3.3 | Flow Diagram for the Arterial Probe Vehicle Algorithm | 59 |
| Figure 4.1 | Decision Tree of Expressway Incident Detection Algorithm | 63 |
| Figure 4.2 | Comparison of Evaluation Results with Estimation Results | 69 |
| Figure 4.3 | Comparison of Results: Estimation on Edens, Evaluation Application on Kennedy and Estimation on Kennedy | 70 |

List of Tables

| | | |
|------------|---|----|
| Table 2.1 | Incident Type and Duration Analyses | 12 |
| Table 2.2 | Average Volume and Occupancy for Weekday Peak Periods (by detectors) ... | 15 |
| Table 2.3 | Initial Evaluation Results of Fixed Detector Incident Detection Model | 18 |
| Table 2.4 | The Effect of Heuristic Rules on the Incident Detection | 19 |
| Table 2.5 | Effect of Peak vs. Off-Peak Periods on Incident Detection | 20 |
| Table 2.6 | Comparison of Detection Effectiveness by Incident Categories | 21 |
| Table 2.7 | Fixed Detector Detection Discriminant Parameters and Classification Performance | 23 |
| Table 2.8 | Comparison of Models with Standardized Variables and with Original Variables | 25 |
| Table 2.9 | Time Period of Incident Detection Relative to Time Period of NWCD Report | 26 |
| Table 2.10 | Detection Effectiveness by Incident Categories | 26 |
| Table 2.11 | Model Estimation for Peak and Off-peak Periods | 29 |
| Table 2.12 | Model Estimation for Major Incidents Only | 30 |
| Table 3.1 | Estimated Parameters for Discriminant Function and Cut-off Points | 40 |
| Table 3.2a | Evaluation Results of Probe Vehicle Incident Detection Model | 45 |
| Table 3.2b | Evaluation Results of Probe Vehicle Incident Detection Model | 46 |
| Table 3.3 | The Initial Evaluation of Probe Vehicle Incident Detection Algorithm | 47 |
| Table 3.4 | Probe Vehicle Detection Discriminant Parameters and Classification Performance Based on Single Reports | 50 |
| Table 3.5 | Probe Vehicle Detection Discriminant Parameters and Classification Performance Based on Three Reports | 54 |
| Table 4.1 | Estimation Thresholds and Results | 64 |
| Table 4.2 | Evaluation Results of Kennedy Expressway, Inbound | 67 |
| Table 4.3 | Comparison of Evaluation Results with Estimation Results | 68 |

1. INTRODUCTION

1.1 Objective of Incident Detection

An important objective of the *ADVANCE* Project is to provide participating drivers with real-time route planning information, based on up-to-date travel times on the links in the *ADVANCE* area. Since most drivers will be local residents, with considerable knowledge about the local network and information about recurring congestion; navigational guidance based on historic values of travel time will be of limited value. Incidents, on the contrary, are non-recurring events on the network which can have significant impacts, which cannot be anticipated by drivers, on link travel times. Thus, real-time information, regarding the occurrence of incidents and their location, will be valuable even to those travelers who are familiar with the network and have some knowledge of expected travel times under "normal conditions." The effectiveness of the *ADVANCE* incident detection algorithm and its successors has the potential to enhance the effectiveness of dynamic route guidance both for ATIS users and others.

1.2 Multiple Data Sources for Arterial Incident Detection

The *ADVANCE* incident detection system for arterial roads uses three sources of information to identify incident conditions on the network. These include: (1) fixed detectors which provide occupancy and volume data averaged over a limited time period for specific sections of selected network links, (2) probe vehicles which travel freely on the network and report link travel times, and (3) anecdotal reports of particular events affecting traffic flow provided by people traveling on or monitoring the road network.

Fixed detectors provide a continuous stream of volume and occupancy data aggregated

over a certain time interval (*e.g.*, every five minutes) across all lanes at a limited number of fixed locations¹. Probe vehicles and anecdotal sources provide data intermittently at locations determined by the location of the probe equipped vehicle or the reporting source, respectively. Specifically, probe vehicles will provide travel time for links when they complete traversals of those links. During any time interval, probe reports will be available for only a small number of links due to the small number of probe vehicles traversing the network during a given time interval. Similarly, anecdotal data will be available only when emergency personnel or motorists report a traffic incident on the link.

1.3 Expressway Incident Detection

A more limited incident detection capability for expressways in the *ADVANCE* and adjacent areas is based on estimation of the California incident detection algorithm with data from fixed detectors which are located at approximately one-half mile intervals for the center lane of express roadway (Koppelman and Lin, 1996)².

¹ The fixed detectors in the *ADVANCE* area are part of the traffic signal control system. Detectors located on Dundee Road between Milwaukee Avenue and Rand Road are generally located approximately 90 meters upstream from signalized intersections. Detectors at 26 locations are linked to the *ADVANCE* Traffic Information Center (TIC) and provide information on volume (total across lanes) and occupancy (average across lanes) for each five minute period.

² Expressway detectors are linked to the Traffic System Center of the Illinois DOT and volume and occupancy data for each one minute interval is forwarded to the *ADVANCE* TIC.

1.4 Purpose and Scope

The purpose of this report is to evaluate the performance of the automatic incident detection algorithms for arterial roads (probe vehicle, fixed detector, and fused) and for expressways. The evaluation of the arterial fixed detector algorithm is undertaken by collecting data from loop detectors along Dundee Road and from NWCD logs³ for incident verification. Evaluation of the probe vehicle algorithm is based on data which is collected through the assignment of a fleet of vehicles to travel on incident links to acquire current travel time and related information for these links under incident and non-incident conditions⁴ and incident reports from NWCD logs. Evaluation of the fused algorithm was to be based on loop detector, probe vehicle and NWCD incident data along Dundee Road. However, this evaluation could not be completed due to the absence of incidents along this portion of Dundee Road on dates when probe vehicles were assigned to incident detection evaluation. Evaluation of the expressway incident detection algorithm is undertaken by collecting automatic data from loop detectors along an expressway and comparing it to incident data based on cellular phone and Emergency Traffic Patrol reports⁵. The incident detection evaluation uses these data to calculate

³ Northwest Central Dispatch (NWCD) transmitted all traffic related emergency reports on roadways in their jurisdiction which covers approximately one-half of the *ADVANCE* test area to the *ADVANCE* TIC. Twenty-two of the Dundee Road detector stations are in the NWCD area.

⁴ Incident conditions are monitored by assigning vehicles to links on which incidents are reported; non-incident conditions are monitored by assigning vehicles to the same links on subsequent days. The planned use of data from traversals under construction (pseudo incident) and non-construction conditions was not undertaken as construction projects on these links continued through the entire data collection period.

⁵ The interpretation of cellular phone (*999) and Emergency Traffic Patrol Reports is described in Task Report TRF-ID-311/312 (Koppelman and Lin, 1996).

incident detection and false alarm rates for each incident detection algorithm.

Additional analysis is undertaken to determine the extent to which modifications to the implemented arterial algorithms will improve their performance.

1.5 Report Structure

The remainder of this report is organized as follows. The algorithms for arterial fixed detector, arterial probe vehicle and expressway are discussed and analyzed in Sections 2, 3 and 4, respectively. Each section describes the logic of the algorithm and the type of data used, then presents the evaluation and, as appropriate, modification of the specific algorithm. Finally, the implementation and algorithm description are presented. Section 5 summarizes the overall results.

2. FIXED DETECTOR ALGORITHM

2.1 Overview

2.1.1 Concept

An incident which impacts traffic flow is expected to increase occupancy⁶ upstream and decrease occupancy downstream from the incident and to reduce the flow rate (volume) both upstream and downstream of the incident. Further, average speed is likely to decrease upstream of the incident due to increased congestion. The changes in volume and occupancy are directly measurable at detectors located upstream and downstream of the incident provided that the distance between the incident location and the detectors is limited. Speed effects can be estimated indirectly by the ratio of volume to occupancy, which is positively related to the speed⁷.

The arterial fixed detector algorithm compares current detector readings to historic average values for the corresponding day type and time period to identify differences in traffic flow conditions. Current occupancies and volumes are reported from detectors at 22 locations in the Dundee Rd. corridor at the end of each five minute period. The historic occupancies and volumes for each detector are the average value recorded at the detector, under normal traffic flow conditions⁸, for the corresponding time period and day type⁹.

⁶ Occupancy is the percentage of time that the space above the detector is occupied by a vehicle.

⁷ The relationship between this ratio and speed is likely to be monotonic but non-linear on arterial links (Berka *et al.*, 1995).

⁸ Normal conditions are when there is no incident on the roadway.

⁹ Day type consists of four categories: Monday through Thursday, Friday, Saturday and Sunday.

Variables based on current volume and occupancy and their relationship to historic volume and occupancy were formulated and tested to select a preferred model based on fixed detector data under simulated incident and non-incident conditions. The measures considered include the following variables collected at both the upstream and downstream detector stations:

- | | |
|--|--|
| 1) Occupancy Deviation (OCCDEV): | Deviation of occupancy from its historic value, OCCOBS - OCCMEAN; |
| 2) Volume Deviation (VOLDEV): | Deviation of volume from its historic value, VOLOBS - VOLMEAN; |
| 3) Occupancy Ratio (OCCRAT): | Ratio of occupancy to its historic value, OCCOBS / OCCMEAN; |
| 4) Volume Ratio (VOLRAT): | Ratio of volume to its historic value, VOLOBS / VOLMEAN; |
| 5) Deviation of Volume by Occupancy Ratio (VBYODEV): | Deviation of volume by occupancy from historic value, VBYO_OBS - VBYOMEAN; |
| 6) Ratio of Volume by Occupancy Ratio (VBYORAT): | Ratio of volume by occupancy to historic value, VBYO_OBS / VBYOMEAN. |

where,

- | | |
|-----------|--|
| OCCOBS: | observed occupancy, |
| OCCMEAN: | historic occupancy ¹⁰ , |
| VOLOBS: | observed volume, |
| VOLMEAN: | historic volume, and |
| VBYO_OBS: | observed ratio of volume by occupancy. |
| VBYOMEAN: | historic ratio of volume by occupancy. |

The estimation approach for the arterial incident detection algorithm was described in Sethi *et al.* (1995) as follows: "Models were estimated using discriminant analysis (Klecka,

¹⁰ The historic values for occupancy, volume and volume by occupancy are obtained by averaging values for non-incident periods for corresponding time periods and day types.

1980) in which a linear combination of variables is used to classify cases into two mutually exclusive groups, incident and non-incident conditions. The models were calibrated using cases for which the group membership was known. In discriminant analysis, the coefficients are estimated so that the 'values of the discriminant function differ.. as much as possible between the groups' (Norusis, 1988). Classification using discriminant analysis is dependent on a discriminant score, which is a function of the measured variables and the prior probability of an accident. The prior probabilities reflect the expected share of observations (time periods on a link) during which an incident is likely to occur."

The model with the best performance in terms of the detection rate and false alarm rate included the occupancy deviation and the volume by occupancy deviation, both measured at the upstream detector station (Koppelman *et al.*, 1994). These variables are used to compute a discriminant score (Green, 1979). If the score exceeds zero, the fixed detector algorithm classifies the condition as an incident on the section of the roadway associated with the detector.

2.1.2 Initial Field Testing

An initial field test was based on fixed detector data only since the incident confirmation data from NWCD was not available. The lack of confirmed incident reports precluded recalibration of the fixed detector algorithm (Bhandari *et al.*, 1995). However, the fixed detector data was used to examine the performance of the fixed detector algorithm under apparent non-incident conditions.

The fixed detector data covered most of the five minute time periods from November 20, 1994 to February 1, 1995. The algorithm generated 814 incident alarms, all of which were

presumed to be false alarms¹¹ from 51,455 detector reports (detectorized links by time period). An investigation of this data led to the adoption of the following heuristic rules which eliminated all these alarms:

- An incident is not declared if current occupancy is below a predefined threshold. This threshold occupancy level is set at 20%, when travel time is virtually independent of occupancy (Sisiopiku *et al.*, 1994).
- An incident is not declared if the flow volume is greater than its historic value (independent of the occupancy level).
- An incident is not declared if the flow volume is greater than 60 vehicles per 5 minutes per lane (*i.e.*, 720 vehicles per hour per lane).

A discriminant score, FD_DISC_FUNC, is computed as follows :

$$FD_DISC_FUNC = \beta_0 + \beta_1*OCCDEV + \beta_2*OCCRAT + \beta_3*VOLDEV + \beta_4*VOLRAT + \beta_5*VBYODEV + \beta_6*VBYORAT$$

where the modified model parameters are:

$$\begin{aligned} \beta_0 &= -14.880, \\ \beta_1 &= 0.0192, \\ \beta_2 &= 0.0^{12}, \\ \beta_3 &= 0.0, \\ \beta_4 &= 0.0, \\ \beta_5 &= -4.088, \\ \beta_6 &= 0.0. \end{aligned}$$

¹¹ In the absence of confirmed incident reports, it was assumed that there were no incidents during the time periods corresponding to the detector data used for testing. The large number of incident reports indicated that this assumption was correct for most, if not all, incident identifications. Assuming all were false alarms resulted in an algorithm which is conservative; that is, it will identify a relatively small number of incidents which produce large travel flow impacts while generating very few false alarms.

¹² Inclusion of variables with zero weight allows the function to be modified easily to include additional variables by changing the weight to a non-zero value.

If the discriminant score is greater than 0, an incident is flagged for the link associated with the detector for the corresponding time period; if the discriminant score is less than 0, normal conditions are assumed.

2.1.3 Fixed Detector Calibration

Initial field calibration was undertaken based on fixed detector data for the period from April 28th, through June 29th, 1995, and incident data in the Dundee Rd. corridor reported by NWCD (Koppelman and Tsai 1995). During this period, 50 incidents were reported in the Dundee Rd. corridor. Of these, 37 incidents were excluded because they occurred during periods when fixed detector data was not available or the detector data was well within the normal range at that location. The remaining 13 incidents generated 276 incident observations (detector locations by time period) out of 270,084 detector reports (detector locations by time period).

Model estimations were undertaken with variables defined in section 2.1.1. Based on the results, the fixed detector algorithm was modified by adjusting the screening rule for volume from 60 to 70 vehicles per lane per five minutes and modifying the coefficients to:

$$\begin{aligned}\beta_0 &= -7.623, \\ \beta_1 &= 0.154, \\ \beta_2 &= 0.0, \\ \beta_3 &= -0.039, \\ \beta_4 &= 0.0, \\ \beta_5 &= -0.046, \\ \beta_6 &= 0.0.\end{aligned}$$

With this modification, volume deviation (VOLDEV) at the upstream detector is added to the algorithm.

2.2 Field Data Collection for Evaluation

2.2.1 Data Description

The evaluation of the fixed detector algorithm uses the Dundee Rd. detector data and the NWCD incident records. These data were logged on a daily basis from October 1st, through November 30th, 1995. Fixed detector data are often missing in the early morning hours and sometimes during other time periods for a variety of reasons including malfunction of loop detectors.

The NWCD reports include information regarding incident location, received time (initial incident report) and clear time (incident termination) and incident type. The incident start time is set at 30 minutes before the first report received on the possibility that there may be a delay in reporting the incident. The rule for selection of the incident start time is arbitrary. Data which includes true incident start times, based on driver reports, and time of the first NWCD incident report would be required to provide a non-arbitrary basis for selecting incident start time¹³. A change in the incident start time will cause a corresponding change in the mean time to detect. That is, the assumption of later (earlier) start times will reduce (increase) the mean time to detect. The end time is set at 15 minutes after the clear time of the report because it is possible that the police or fire department units clear (depart from the incident location) before traffic flow returns to normal. The selection of incident end time is arbitrary but has no impact on any of the performance measures included in the evaluation. Most of the incident reports do not include information about the direction of the incident lanes. In addition, the incident

¹³ Collection of this information requires continuous monitoring of the roadway by observers or closed circuit televisions.

location is given in terms of a recognized reference point (usually an intersection) but without direction and distance to the incident site so the exact incident location is generally not known. We adopt the convention that the incident is in the vicinity of the reported location and attempt to detect the incident at all detector stations upstream from that location on any adjacent link.

During the evaluation test period, 151 incidents were reported in this portion of Dundee Road. Ten incidents were excluded because they occurred during periods when fixed detector data was not available at the incident location. The remaining 141 incidents generated 4,439 incident observations (detector locations by time period) out of 289,161 detector reports (detector locations by time period).

Incidents are classified into three categories: (1) accident-- includes accident with property damage or injuries, activated fire alarms, and hazardous material spills; (2) law enforcement-- includes traffic stop and arrest, suspended driver's license, and motorist assistance; and (3) other-- includes hit and run with property damage, ambulance calls and light malfunction. Of these incidents, about half are considered minor incidents (law enforcement) which have little impact on traffic flow and are expected to be difficult to detect (see Table 2.1).

Table 2.1 Incident Type and Duration Analyses

| Incident Type | | Cases | Average Duration (minutes) |
|-----------------|----------------------------------|-------|----------------------------|
| Law Enforcement | Traffic Stop | 48 | 22.3 |
| | Traffic Arrest | 2 | 62.5 |
| | Suspended Driver License | 1 | 35.0 |
| | Motorist Assistance | 19 | 25.3 |
| Accident | Accident with Property Damage | 27 | 45.9 |
| | Accident with Injuries | 14 | 41.8 |
| | Activated Fire Alarm | 8 | 23.1 |
| | Hazard Material Spill | 1 | 10.0 |
| Others | Light Malfunction | 3 | 23.3 |
| | Ambulance Call | 12 | 28.3 |
| | Hit and Run with Property Damage | 2 | 77.5 |
| | Other | 4 | 23.8 |
| Total | | 141 | 31.3 |

2.2.2 Preliminary Analysis

The time-of-day distribution of average volume and occupancy for two stations, westbound at Wilke Road and Eastbound at Buffalo Grove, are given in Figures 2.1 and 2.2, respectively. The figures show that (1) the volume and occupancy patterns differ greatly by location and flow direction and (2) there is considerable variation in volume and occupancy by time of day, especially for afternoon peak periods in the eastbound direction. These results imply that there is a need to compute historic average value of occupancy and volume separately

for each station and time of day.

The average volume and occupancy of each station during weekday peak periods¹⁴, under incident and non-incident conditions, are given in Table 2.2. The results show that average occupancy is higher during incident periods at every station and that average volume is lower at ten of the thirteen stations where incidents occurred. Incidents which result in volume increase are likely to be more difficult detect than incidents which follow the expected pattern; increase in occupancy and decrease in volume.

Figure 2.3 shows the distribution of deviation of volume and occupancy (current values minus historic values), for both incident and non-incident periods (because of the large number of non-incident periods, only 1% of these are included). The deviation values of more than half of the incidents are within the range of values commonly observed during non-incident periods. A more detailed view of these data for values of occupancy deviation greater than ten including fifty percent of non-incident periods indicates that very few incidents can be distinguished from non-incident data if the model is based exclusively on occupancy and volume deviation (Figure 2.4). This indicates that unless the algorithm incorporates other variables, large numbers of false alarms will be generated in any effort to detect more than a small fraction of incidents.

¹⁴ The data in this table is for peak periods, 6:00-9:00am and 4:00-7:00pm, to control for time of day variability. 40 of the 141 incidents occur during peak periods.

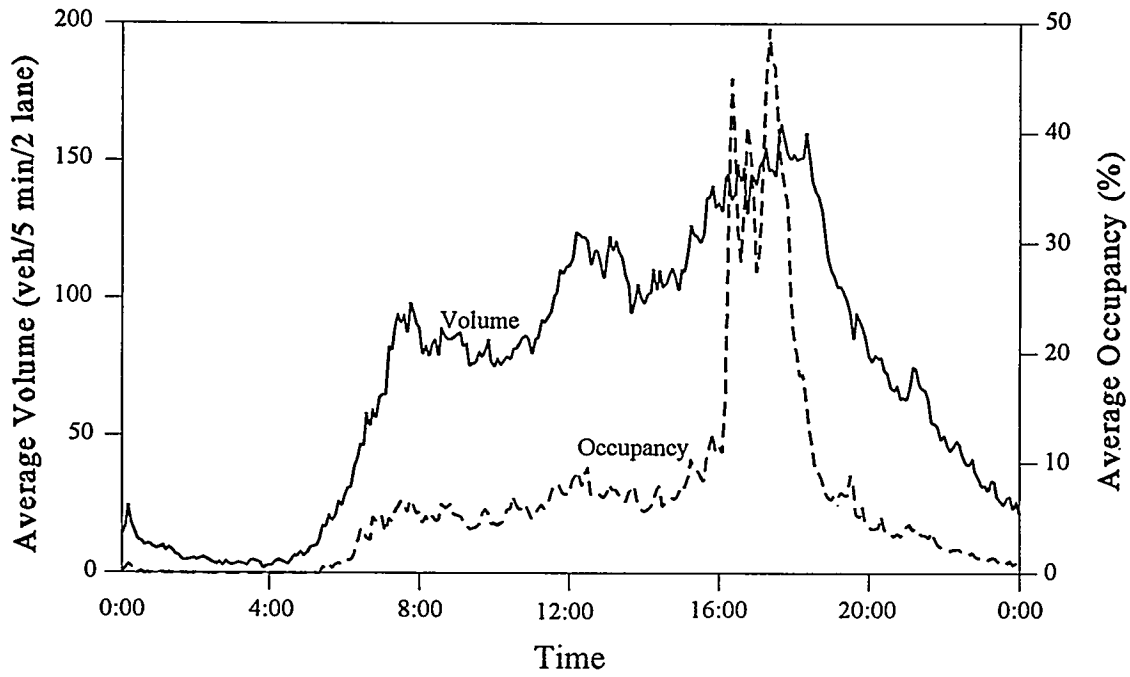

Figure 2.1 Average Volume and Occupancy for Detectors at Wilke Rd, Westbound on Dundee

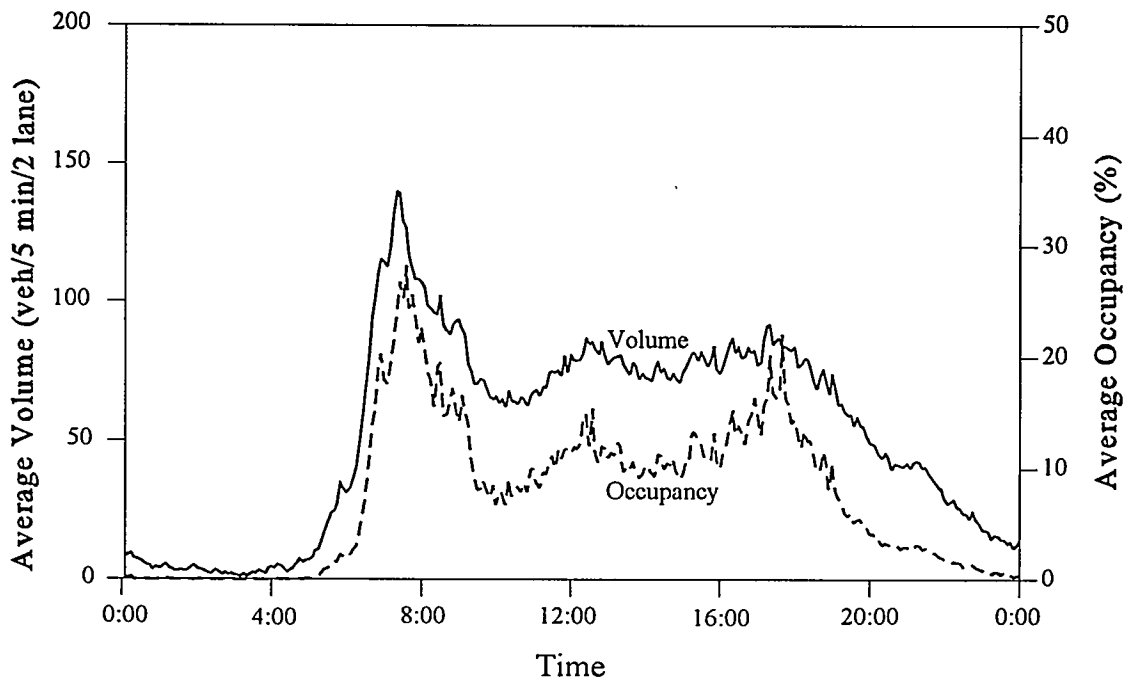
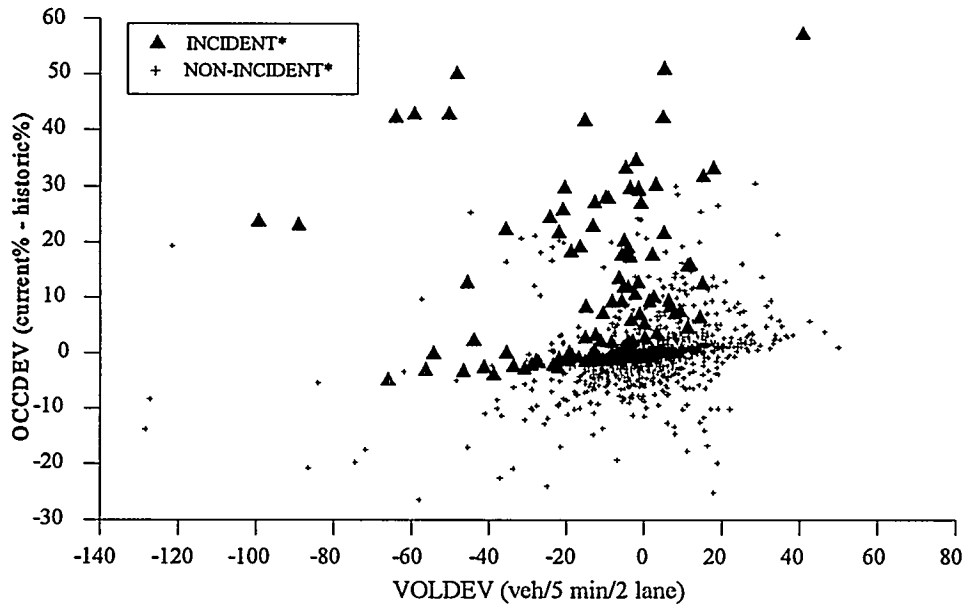

Figure 2.2 Average Volume and Occupancy for Detectors at Buffalo Grove, Eastbound on Dundee

Table 2.2 Average Volume and Occupancy for Weekday Peak Periods (by detectors)

| Detector Station | | | Incident Data | | | Non-Incident Data | |
|------------------|----------|---------------------|----------------|--------|-----------|-------------------|-----------|
| Master No. | Detector | Location, Direction | No of Incident | Volume | Occupancy | Volume | Occupancy |
| 1 | 13,14 | E. Frontage, EB | 5 | 119.20 | 35.80 | 148.06 | 11.56 |
| | 15,16 | E. Frontage, WB | 3 | 81.66 | 51.00 | 115.04 | 17.86 |
| | 17,18 | Baldwin, EB | 5 | 45.20 | 35.20 | 74.67 | 15.26 |
| | 1,2 | Arlington Hts, EB | 4 | 85.50 | 7.00 | 102.96 | 5.49 |
| | 19,20 | Crofton, EB | 0 | | | 43.85 | 3.06 |
| | 21,22 | Arlington Hts, WB | 0 | | | 83.73 | 11.80 |
| | 23,24 | Arlington Hts, NB | 3 | 64.67 | 53.67 | 65.42 | 17.13 |
| | 25,26 | Arlington Hts, SB | 1 | 50.00 | 32.00 | 57.93 | 10.63 |
| | 3,4 | W. Frontage, WB | 4 | 138.50 | 27.00 | 108.50 | 8.69 |
| | 7,8 | IL53 E. Ramp, EB | 1 | 51.00 | 7.00 | 76.77 | 6.41 |
| | 9,10,11 | IL53 E. Ramp, NB | 0 | | | 95.20 | 18.28 |
| 92 | 11,12 | Buffalo Grove, SB | 1 | 44.00 | 15.00 | 52.32 | 14.45 |
| | 13,14 | Lake, WB | 0 | | | 99.17 | 12.24 |
| | 15,16 | IL83, EB | 0 | | | 92.43 | 16.85 |
| | 17,18 | IL83, WB | 0 | | | 75.58 | 11.85 |
| | 19,20 | IL83, NB | 0 | | | 74.78 | 9.85 |
| | 1,2 | Golfview, EB | 0 | | | 112.33 | 6.27 |
| | 21,22 | IL83, SB | 0 | | | 48.83 | 8.79 |
| | 3,4 | Golfview, WB | 6 | 92.33 | 7.83 | 102.62 | 5.96 |
| | 5,6 | Buffalo Grove, EB | 3 | 86.33 | 23.66 | 88.02 | 15.35 |
| | 7,8 | Buffalo Grove, WB | 2 | 114.50 | 39.50 | 93.04 | 16.37 |
| | 9,10 | Buffalo Grove, NB | 2 | 66.50 | 53.00 | 45.87 | 8.76 |



*Include all incidents and 1% non-incidents.

Figure 2.3 Occupancy Deviation and Volume Deviation for Incident and Non-incident Cases

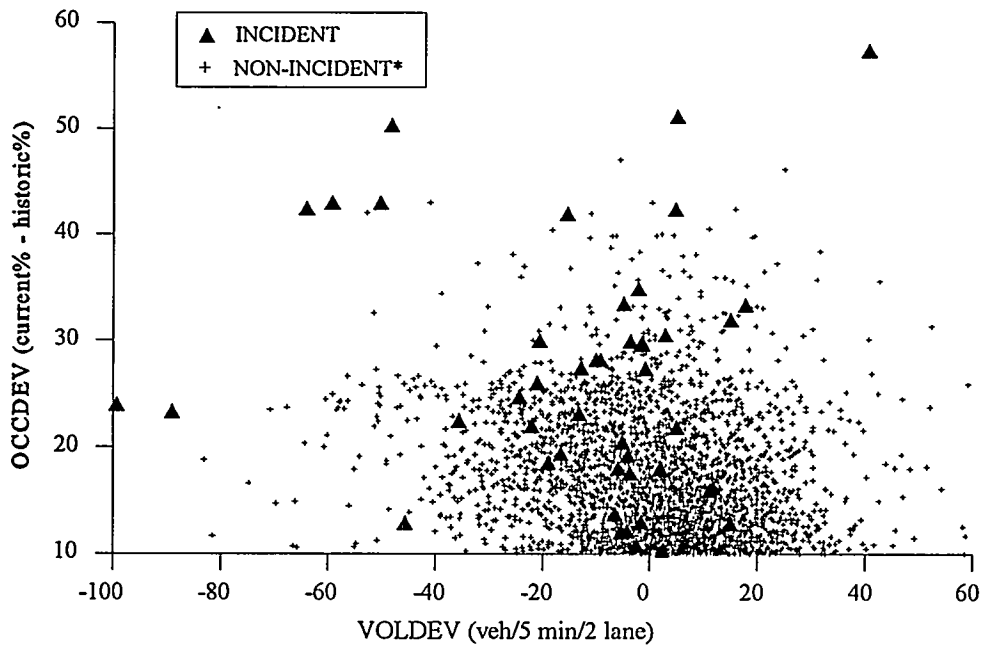

*Includes 50% non-incidents.

Figure 2.4 Occupancy Deviation and Volume Deviation for Incident and Non-incident Cases with Increased Detail in Critical Range

2.3 Evaluation Results

2.3.1 Overview

The performance of the fixed detector incident detection algorithm is evaluated by the number of incidents detected, the number of false alarms and the mean time to detect an incident. Initial evaluation is based on all incidents for which fixed detector and incident validation data is available using the implemented algorithm which was based on initial field data (Section 2.1.3). Further evaluation is performed incorporating screening rules which were developed based on limited field data. Three sets of screening rules are examined to see if any of them improve the overall level of algorithm performance by decreasing false alarms while maintaining incident detection.

Additional evaluation was undertaken to consider the extent to which the performance results are influenced by the time of day or the incident types considered. Incident detection is expected to be better during peak (heavy travel) time periods because it is during these time periods that a loss of roadway capacity is likely to have the greatest impact on traffic flow characteristics. This additional evaluation is undertaken by splitting the data into peak periods defined as 6:00am to 9:00am and 4:00pm to 7:00pm, Monday through Friday, and all other time periods. Also, it is expected that more severe incidents (*e.g.*, accident with injuries) are likely to have a more substantial impact on traffic flow than other incidents (*e.g.*, traffic arrest). Therefore, they will be easier to distinguish from normal traffic conditions than other incident types. The effect of differentiating incident types (accident and other vs. law enforcement) on incident detection will be explored.

2.3.2 Overall Evaluation

An overall evaluation is undertaken with the variables and parameters defined in Section 2.1.3 for all reported incidents. Table 2.3, reports that 7 out of 141 incidents are detected with a mean time to detect of 35 minutes (or 5 minutes after the first NWCD report). The low incident detection rate is due, in part, to the fact that most of the incidents are minor incidents or incidents occurring during off-peak periods: 70 are minor incidents including traffic stop, traffic arrest, and motorist assistance and 101 incidents occur during off-peak periods; only 26 incidents are major incidents occurring during peak periods¹⁵. On the other hand, 9 false alarms are declared by the model. Although this number is low, it is greater than the number of detected incidents.

Table 2.3 Initial Evaluation Results of Fixed Detector Incident Detection Model

| Number of Incidents | Number of Detected Incidents | Number of Detected Incident Periods | Number of False Alarms | Mean Time to Detect (min.) |
|---------------------|------------------------------|-------------------------------------|------------------------|----------------------------|
| 141 | 7 | 32 | 9 | 35.0 |

An interesting result is that none of the incidents detected are in the area covered by master¹⁶ 92. For unknown reasons, the incident data for detectors linked to master 92 are less distinct from non-incident data than for detectors linked to master 1 (see Table 2.2). It is particularly surprising that of the four Master 92 detector stations where incidents were reported,

¹⁵ Differences in detection by time period and incident type are examined in Sections 2.3.4 and 2.3.5, respectively.

¹⁶ Fixed detector data is initially routed to a Master Controller which manages signal progression for multiple intersections. There are two master controllers in this section of Dundee Road, Master 92 and Master 1.

volume does not decrease as expected in some cases (volumes are higher during incident periods than non-incident periods for two cases and about the same for another case).

2.3.3 Evaluation with Heuristic Screening Rules

A variety of screening rules were proposed to reduce the number of false alarms generated during initial field testing with the objective of not substantially reducing the number of incidents detected. Three distinct screening rules are evaluated as shown in Table 2.4. These rules include only those time periods for which:

- Volume is less than or equal to 70 vehicles per lane per 5 minutes.
- Current volume is less than its historic average and current occupancy is greater than 20%.
- Current occupancy is greater than 20% and occupancy temporal difference (OCCTD, current occupancy minus occupancy 5 minutes ago) is greater than 5%.

Table 2.4 The Effect of Heuristic Rules on the Incident Detection

| Screening Rules | No. of Incidents which Satisfy Screening Rule(s) | No. of Detected Incidents | No. of Detected Incident Periods | No. of False Alarms |
|--|--|---------------------------|----------------------------------|---------------------|
| $Vol \leq 70$ | 140 | 5 | 28 | 9 |
| $Vol \leq His_vol$ and $Occ \geq 20\%$ | 45 | 7 | 23 | 9 |
| $Occ \geq 20\%$ and $Occtd \leq 5\%$ | 45 | 4 | 10 | 5 |
| No Screening | 141 | 7 | 32 | 9 |

Only the third screening rule reduces the number of false alarms and that rule reduces the number of incidents detected by a similar fraction. The other rules reduce the number of incidents detected without reducing the number of false alarms. That is, the proposed screening rules are equally or more likely to reduce incident detection than to reduce false alarms. Such screening rules do not provide a satisfactory approach to improving incident detection results.

2.3.4 Evaluation by Time of Day

The evaluation results by peak and off-peak periods are reported in Table 2.5. The peak period results are better than the off-peak period results. Although less than one-third of incidents occur during peak periods, most detected incidents (6 out of 7) are during peak periods. Two factors appear to contribute to poor incident detection during off-peak periods. First, more than half of all incidents during off-peak periods (56 out of 101) are minor incidents (traffic stop, traffic arrest, and motor assistance) which are more difficult to detect than the others. Second, the level of congestion is lower during off-peak periods so incidents which occur during these periods are likely to have a much smaller impact on traffic flow than those which occur during peak periods.

Table 2.5 Effect of Peak vs. Off-Peak Periods on Incident Detection

| | No. of Incidents | No. of Detected Incidents | No. of Detected Incident Periods | No. of False Alarms |
|-------------|------------------|---------------------------|----------------------------------|---------------------|
| Peak | 40 | 6 | 28 | 9 |
| Off-Peak | 101 | 1 | 4 | 0 |
| Pooled Data | 141 | 7 | 32 | 9 |

2.3.5 Evaluation by Incident Type

Table 2.6 shows the evaluation results by incident type. All the incidents detected are either "accidents" or "other" (not law enforcement related incidents). This indicates that law enforcement incidents, most of which are undertaken in a manner to minimize the impact on traffic flow, are likely to be difficult to detect and consideration should be given to estimating an incident detection algorithm using data which excludes these incidents. The remaining categories (accident and other) have similar detection results (4 out of 50 accidents; 3 out of 21 other incidents).

Table 2.6 Comparison of Detection Effectiveness by Incident Categories

| Incident Category | No. of Incidents | No. of Detected Incidents | No. of Detected Incident Periods |
|-------------------|------------------|---------------------------|----------------------------------|
| Accident | 50 | 4 | 16 |
| Law Enforcement | 70 | 0 | 0 |
| Others | 21 | 3 | 16 |
| All Incidents | 141 | 7 | 32 |

2.3.6 Summary

The overall evaluation results are less than satisfactory. Only 7 of 141 incidents were detected. The number of false alarms is larger than the number of detected incidents. One of the reasons for this poor performance of the algorithm is that about 70% of total incidents occurred during off-peak periods and almost 50% of total incidents are minor.

The inclusion of heuristic screening rules does not have a positive effect on the incident detection. The evaluation results by time of day and incident types indicate that the algorithm performs best when (1) it is applied to peak periods and (2) for detection of other than law enforcement incidents.

The following section explores alternative approaches for enhancing the performance of the algorithm.

2.4 Modifications of Arterial Fixed Detector Incident Detection Algorithm

2.4.1 Re-calibration with Current Variables

Six current variables described in Section 2.1.1 are considered: occupancy deviation (OCCDEV); occupancy ratio (OCCRAT); volume deviation (VOLDEV); volume ratio (VOLRAT); volume by occupancy deviation (VBYODEV); and volume by occupancy ratio (VBYORAT). Algorithm modifications with these variables were undertaken using the evaluation data. Table 2.7 reports the discriminant parameters and classification results for different thresholds¹⁷ for three preferred specifications among many considered. Only model 3, with the same specification as the tested model, combined with a threshold of -5.0 is equal to or better than the tested model (Table 2.3); it detects the same number of incidents, detects more incident periods and generates fewer false alarms. This result supports the selection of the tested specification (among the specifications based on the occupancy, volume and volume by

¹⁷ The thresholds are selected to illustrate a range of results with respect to incidents detected and false alarms. The selection of a preferred threshold reflects judgement about the importance of reducing the number of false alarms at the cost of reducing the number of incidents detected.

occupancy variables). However, it also indicates the limitation of this specification to provide an effective arterial incident detection algorithm.

Table 2.7 Fixed Detector Detection Discriminant Parameters and Classification Performance

| Model 1 | | | | Model 2 | | | | Model 3 | | | |
|-----------|--------------|--------------------|---------------------------|-----------|--------------|--------------------|---------------------------|-----------|--------------|--------------------|---------------------------|
| OCCDEV | | 0.120 | | OCCDEV | | 0.140 | | OCCDEV | | 0.238 | |
| OCCRAT | | 0.324 | | OCCRAT | | 0.308 | | OCCRAT | | | |
| VOLDEV | | | | VOLDEV | | -0.0371 | | VOLDEV | | -0.0454 | |
| VOLRAT | | | | VOLRAT | | | | VOLRAT | | | |
| VBYODEV | | -0.0604 | | VBYODEV | | -0.0509 | | VBYODEV | | -0.0394 | |
| VBYORAT | | | | VBYORAT | | | | VBYORAT | | | |
| CONSTANT | | -12.913 | | CONSTANT | | -11.630 | | CONSTANT | | -15.824 | |
| Threshold | False Alarms | Detected Incidents | Detected Incident Periods | Threshold | False Alarms | Detected Incidents | Detected Incident Periods | Threshold | False Alarms | Detected Incidents | Detected Incident Periods |
| 0 | 1 | 5 | 9 | 0 | 6 | 5 | 9 | 0 | 1 | 0 | 0 |
| -2.5 | 11 | 5 | 10 | -1.5 | 16 | 6 | 12 | -5.0 | 7 | 7 | 39 |
| -3.0 | 16 | 6 | 11 | -2.0 | 23 | 8 | 16 | -5.5 | 22 | 8 | 49 |
| -4.0 | 43 | 7 | 12 | -3.0 | 43 | 11 | 36 | -6.0 | 33 | 10 | 59 |
| -5.0 | 101 | 10 | 19 | -4.0 | 128 | 16 | 72 | -7.0 | 95 | 10 | 80 |

2.4.2 Extended Specification with Additional Variables

Due to the poor performance of all the algorithms based on the original set of variables, further modification of the algorithm was undertaken. Three new variables, standardized versions of the original variables, were considered. In each case, the standardized variables are obtained by dividing the deviation variables in the preferred model by their historical standard deviation during non-incident periods for the corresponding time period and day type as follows:

$$\text{SOCCDEV} = \text{OCCDEV} / \text{SDOCCDEV}$$

$$\text{SVOLDEV} = \text{OCCDEV} / \text{SDOCCDEV}$$

$$\text{SVBYODEV} = \text{OCCDEV} / \text{SDOCCDEV}$$

where SDxxxxxx is the standard deviation of the historic variable and

Sxxxxxx is the standardized value of the observed variable at the current time.

Thus, the standardized values measure deviations relative to the variability of each variable at different locations by time and day type¹⁸.

The discriminant parameter estimates for the new model with standardized occupancy and volume deviation¹⁹ and the original model (original specification with new parameters, model 3 in Table 2.7) are presented in Table 2.8 with classification results for a range of thresholds selected for each model. The standardized model obtains substantially better results. For a threshold of 1.2, it detects 29 incidents without any false alarms; while the original model could

¹⁸ To avoid unreasonably large values of SOCCDEV and SVOLDEV the minimum standard deviations for historical data are set at 0.5% for occupancy deviation and 3 vehicles per minute per station for volume deviation.

¹⁹ A similar model including standardized volume by occupancy deviation obtained very similar results to the model which includes only standardized volume and standardized occupancy deviation.

not detect any incidents without causing some false alarms and obtained a large number of false alarms to detect a much smaller number of incidents. This result indicates the desirability of adopting the standardized model for use in the identification of arterial incidents.

Table 2.8 Comparison of Models with Standardized Variables and with Original Variables

| Original Model | | | | | | Standardized Model | | | | | |
|----------------|--------------|----------------------|--------------------|--------------------|---------------------------|--------------------|--------------|----------------------|--------------------|--------------------|---------------------------|
| OCCDEV | | 0.238 | | | | SOCCDEV | | 1.278 | | | |
| VOLDEV | | -0.0454 | | | | SVOLDEV | | -0.724 | | | |
| VBYODEV | | -0.0394 | | | | CONSTANT | | -7.729 | | | |
| CONSTANT | | -15.824 | | | | | | | | | |
| Threshold | False Alarms | False Alarm Rate (%) | Detected Incidents | Detection Rate (%) | Detected Incident Periods | Threshold | False Alarms | False Alarm Rate (%) | Detected Incidents | Detection Rate (%) | Detected Incident Periods |
| 0 | 1 | 0.0004 | 0 | 0 | 0 | 1.2 | 0 | 0 | 29 | 20.6 | 86 |
| -5.0 | 7 | 0.0025 | 7 | 5.0 | 39 | 0.5 | 6 | 0.0021 | 32 | 22.7 | 93 |
| -5.5 | 33 | 0.0116 | 10 | 7.1 | 59 | 0 | 30 | 0.0105 | 33 | 23.4 | 99 |
| -6.0 | 51 | 0.0179 | 10 | 7.1 | 69 | -0.5 | 76 | 0.0267 | 35 | 24.8 | 105 |
| -7.0 | 95 | 0.0334 | 10 | 7.1 | 80 | -1.0 | 106 | 0.0372 | 36 | 25.5 | 110 |
| -7.5 | 168 | 0.0590 | 13 | 9.2 | 86 | -1.5 | 151 | 0.0530 | 36 | 25.5 | 120 |

The mean time to detect the detected incidents for the selected threshold is 29.5 minutes from the first record or at approximately the same time as the first NWCD report. The number of incidents detected in each ten minute interval, shown in Table 2.9, indicates that some of these incidents would have been detected early enough to provide an earlier warning to NWCD and the emergency services it supports than that obtained using current sources.

Table 2.9 Time Period of Incident Detection Relative to Time Period of NWCD Report

| Time Period | Earlier Time | | | NWCD Report | Later Time | | |
|----------------------|--------------|-------|------|-------------|------------|-------|-----|
| | 20-30 | 10-20 | 0-10 | | 0-10 | 10-20 | 20+ |
| Number of Detections | 7 | 2 | 5 | 1 | 6 | 3 | 5 |

The number of incidents and incident periods detected by incident type for the new model is shown in Table 2.10. These results are superior to the results of the original model (Table 2.6) in every category indicating an across the board improvement in incident detection. Further, these results are obtained with no false alarms rather than seven using the implemented model (Table 2.3).

Table 2.10 Detection Effectiveness by Incident Categories

| Incident Category | No. of Incidents | No. of Detected Incidents | No. of Detected Incident Periods |
|-------------------|------------------|---------------------------|----------------------------------|
| Accident | 50 | 12 | 41 |
| Law Enforcement | 70 | 11 | 28 |
| Other | 21 | 6 | 17 |
| All Incidents | 141 | 29 | 86 |

The sensitivity of these results to selection of the score threshold is illustrated in Figure 2.5 which shows the values of standardized occupancy and volume deviation for the highest score point for each incident and for all non-incident periods (close to the score threshold and

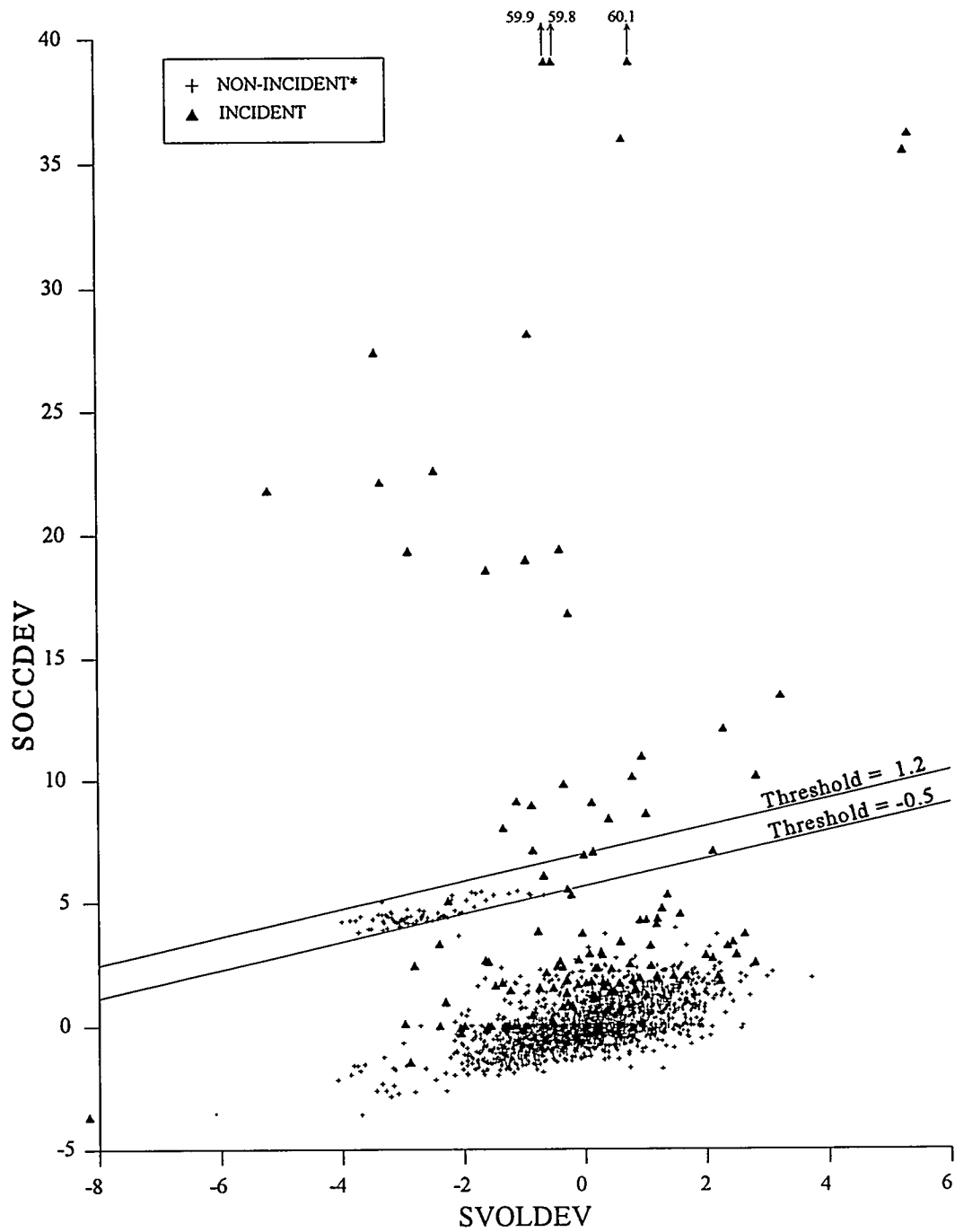

*Includes all non-incident observations above the line of threshold=-0.5 and 1% of non-incident observations below the threshold of -0.5.

Figure 2.5 Incident and Non-incident, Standardized Occupancy Deviation by Standardized Volume Deviation

percent of other non-incident periods). This figure demonstrates that a large fraction of incident observations are well within the data "cloud" for non-incident observations making these incidents "undetectable". Small changes in the threshold (*e.g.*, from -0.5 to +1.2) will screen out large numbers of false alarms.

2.4.3 Model Estimation for Peak and Off-peak Periods

Incidents occurring during peak periods are likely to have more serious impacts on traffic flow than incidents occurring during off-peak periods. The normal travel pattern in peak periods is also different from that in off-peak periods. Therefore, it may be appropriate to use different algorithm parameters during peak periods and off-peak periods. The discriminant parameters and the effect of threshold selection on the false alarm and detection numbers for pooled, peak, and off-peak models are shown in Table 2.11.

The estimation results for the parameters are very similar during peak and off-peak periods and the combined detection results for peak and off-peak models with no false alarms are very close to those for the pooled model; the number of detected incidents increases from 29 to 30 and the number of detected incident periods increases from 86 to 87. Further, the 29 incidents detected by the pooled model are included in the 30 incidents detected by the peak and off-peak models. This small improvement, using a single data set, is not large enough to justify implementing separate models for peak and off-peak periods.

Table 2.11 Model Estimation for Peak and Off-peak Periods

| Pooled Model | | | | Peak Model | | | | Off-peak Model | | | |
|--------------|-----------------------|-----------------------------|---------------------------|------------|-----------------------|-----------------------------|---------------------------|----------------|-----------------------|-----------------------------|---------------------------|
| SOCCDEV | | 1.278 | | SOCCDEV | | 0.994 | | SOCCDEV | | 1.356 | |
| SVOLDEV | | -0.724 | | SVOLDEV | | -0.690 | | SVOLDEV | | -0.579 | |
| CONSTANT | | -7.729 | | CONSTANT | | -5.426 | | CONSTANT | | -13.005 | |
| Threshold | False Alarms (Rate,%) | Detected Incidents (Rate,%) | Detected Incident Periods | Threshold | False Alarms (Rate,%) | Detected Incidents (Rate,%) | Detected Incident Periods | Threshold | False Alarms (Rate,%) | Detected Incidents (Rate,%) | Detected Incident Periods |
| 1.2 | 0 (0) | 29 (20.6) | 86 | 1.9 | 0 (0) | 11 (27.5) | 55 | -4.5 | 0 (0) | 19 (18.8) | 32 |
| 0.5 | 6 (0.0021) | 32 (22.7) | 93 | 1.0 | 5 (0.011) | 14 (35.0) | 65 | -5.0 | 13 (0.0055) | 20 (19.8) | 33 |
| 0 | 30 (0.0105) | 33 (23.4) | 99 | 0 | 39 (0.082) | 14 (35.0) | 73 | -5.5 | 39 (0.0164) | 21 (20.8) | 36 |
| -0.5 | 76 (0.0267) | 35 (24.8) | 105 | -1.0 | 78 (0.164) | 15 (37.5) | 97 | -6.0 | 63 (0.0266) | 22 (21.8) | 38 |
| -1.0 | 106 (0.0372) | 36 (25.5) | 110 | -1.5 | 107 (0.225) | 15 (37.5) | 108 | -6.5 | 102 (0.0430) | 22 (21.8) | 41 |
| -1.5 | 151 (0.0530) | 36 (25.5) | 120 | -2.0 | 189 (0.398) | 19 (47.5) | 128 | -7.0 | 149 (0.0628) | 23 (22.8) | 45 |

2.4.4 Model Estimation for Major Incidents Only

As shown in Section 2.2.1, nearly half of all incidents (70 of 141) are minor incidents (traffic stops, motorist assistance, traffic arrests, and suspended driver license.). These incidents are expected to have little or no impact on traffic flow and are difficult to detect. To detect these incidents, the algorithm tends to lower its criteria for incident alarms and therefore generates more false alarms. This section explores the effect of excluding minor incidents in the discriminant analysis on the algorithm performance. The discriminant coefficients and the

algorithm performance for the all incident and major incident only models are reported in Table 2.12.

Table 2.12 Model Estimation for Major Incidents Only

| All-incident Model | | | | | | Major-incident Model | | | | | |
|--------------------|--------------|----------------------|--------------------|--------------------|---------------------------|----------------------|--------------|----------------------|--------------------|--------------------|---------------------------|
| SOCCDEV | | 1.278 | | | | SOCCDEV | | 1.367 | | | |
| SVOLDEV | | -0.724 | | | | SVOLDEV | | -0.822 | | | |
| CONSTANT | | -7.729 | | | | CONSTANT | | -6.237 | | | |
| Threshold | False Alarms | False Alarm Rate (%) | Detected Incidents | Detection Rate (%) | Detected Incident Periods | Threshold | False Alarms | False Alarm Rate (%) | Detected Incidents | Detection Rate (%) | Detected Incident Periods |
| 1.2 | 0 | 0 | 29 | 20.6 | 86 | 3.4 | 0 | 0 | 18 | 25.4 | 58 |
| 0.5 | 6 | 0.0021 | 32 | 22.7 | 93 | 2.25 | 5 | 0.0018 | 18 | 25.4 | 60 |
| 0 | 30 | 0.0105 | 33 | 23.4 | 99 | 2.0 | 43 | 0.0151 | 20 | 28.2 | 67 |
| -0.5 | 76 | 0.0267 | 35 | 24.8 | 105 | 1.5 | 80 | 0.0281 | 22 | 31.0 | 72 |
| -1 | 106 | 0.0372 | 36 | 25.5 | 110 | 1.0 | 108 | 0.0379 | 22 | 31.0 | 76 |
| -1.5 | 151 | 0.0530 | 36 | 25.5 | 120 | 0.5 | 150 | 0.0527 | 22 | 31.0 | 81 |

Although the detection rate in the major-incident model is higher than in the all-incident model for a similar false alarm rate, the major-incident model detects many fewer incidents, 18 incidents detected in the major-incident model vs. 29 incidents detected in the all-incident model, when no false alarms are generated. Further, the 18 incidents detected in the major-incident model are all included in the 29 incidents detected in the all-incident model. Therefore, the approach of excluding minor incidents does not improve the model performance.

2.4.5 Summary

Re-calibration of the *ADVANCE* fixed detector arterial algorithm results in substantially improved incident detection when new standardized variables are considered. These models detect 29 of 141 total incidents including 18 of 71 important incidents without generating any false alarms. This result is substantially better than that for the original model. Other approaches, including segmentation of the model by time of day and by incident severity, did not substantially improve the ability of the algorithm to discriminate between incident and non-incident.

Based on these results, the model with standardized occupancy and volume deviation, SOCCDEV and SVOLDEV, is preferred. We employ a conservative threshold which will result in relatively few false alarms²⁰ and acknowledge that only those impacts which have severe traffic impacts are likely to be detected. This threshold is incorporated in the algorithm (which is programmed to use a threshold of 0.0) by decreasing the constant from -7.729 to -8.929. The resulting equation for the discriminant score is

$$FD_DISC_FUNC = -8.929 + 1.278 * SOCCDEV - 0.724 * SVOLDEV.$$

2.5 Implementation of the Revised Algorithm

The fixed detector algorithm consists of a module which processes current and historic volume and occupancy data from fixed detectors. The historic volume and occupancy data by day type and time of the day, aggregated over a specified time interval for each detector, is

²⁰ This model obtains no false alarms with the estimation data but would be likely to generate some false alarms if applied to different data.

stored in the 'Historic_Link_Data'. The current volume and occupancy data will be available from the 'TIC_Active_Data'. This data will be screened in TIC for "reasonableness"²¹ to determine if it can be used in the fixed detector algorithm. The parameters for the fixed detector algorithm will be stored in the 'TRF_Data' (Berka *et al*, 1995). The fixed detector algorithm collects the current and historic volume and occupancy data and computes standardized deviations from historic values. It then computes the discriminant score based on these deviations using the parameters reported in Section 2.4.5. The discriminant score will be used to determine incident presence in the proximity of each detector station and identify the roadway links which are affected if a particular detector signals an incident. Incident identifications will be provided to the data fusion module. The fixed detection algorithm will review each detector location during every time period.

The algorithm is identical to that reported in Section 5.2 of TRF-ID-300 and TRF-ID-400 except for changes in variables and parameters in Steps 2.3 and 2.4, exclusion of the heuristic screening rules and elimination of the occupancy only algorithm. Figure 2.6 shows the flow diagram for the fixed detector algorithm. The various steps in the algorithm are:

1. Determine if the data required can be used in the fixed detector algorithm.
 - 1.1 If $O_{tag}=1$ and $V_{tag}=1$ (indicating that both occupancy and volume data are available) *then* go to step 2, *else* go to step 5.
2. Use model with occupancy and volume variables:

²¹ The validity of the detector data is tested for: 1) reasonableness of the occupancy data, 2) reasonableness of the volume data, and 3) consistency of volume and occupancy data. Each test consists of one criterion. Criteria for the first two tests are based on fundamental traffic engineering relationships. The third test is based on the statistical relationship between the two measures.

- 2.1 Obtain current occupancy and volume for the detector station.
 - 2.1.1 Obtain individual detector occupancy and volume for all the detectors at the station.
 - 2.1.2 Compute average occupancy (O_s) and total volume (V_s) for detectors at the same station.
- 2.2 Obtain the historic average occupancy ($O_{\bar{s}}$), average total volume ($V_{\bar{s}}$) and historic standard deviation of occupancy ($O_{\bar{s}\sigma}$) and volume ($V_{\bar{s}\sigma}$) of the detector station for that time period and day type.
- 2.3 Compute the following variables:
 - a) Standardized occupancy deviation: $\text{SOCCDEV} = (O_s - O_{\bar{s}}) / \max(O_{\bar{s}\sigma}, 0.5)$.
 - b) Standardized volume deviation: $\text{SVOLDEV} = (V_s - V_{\bar{s}}) / \max(V_{\bar{s}\sigma}, 3)$.
- 2.4 Compute the discriminant function FD_DISC_FUNC , for the detector s for the time period t as follows:

$$\text{FD_DISC_FUNC} = \beta_0 + \beta_1 * \text{SOCCDEV} + \beta_2 * \text{SVOLDEV},$$
 where the β_i are:

$$\beta_0 = -8.929,$$

$$\beta_1 = 1.278,$$

$$\beta_2 = -0.724.$$
3. If $\text{FD_DISC_FUNC} > 0$, an incident is flagged for the detector for that time period, else the conditions are "normal".
4. Store the discriminant score, classification results and relevant explanatory variables, in a temporary file.

5. Repeat cycle for all detectors.
6. When all detectors are checked, pass the temporary file created in step 4 to ID data fusion module.

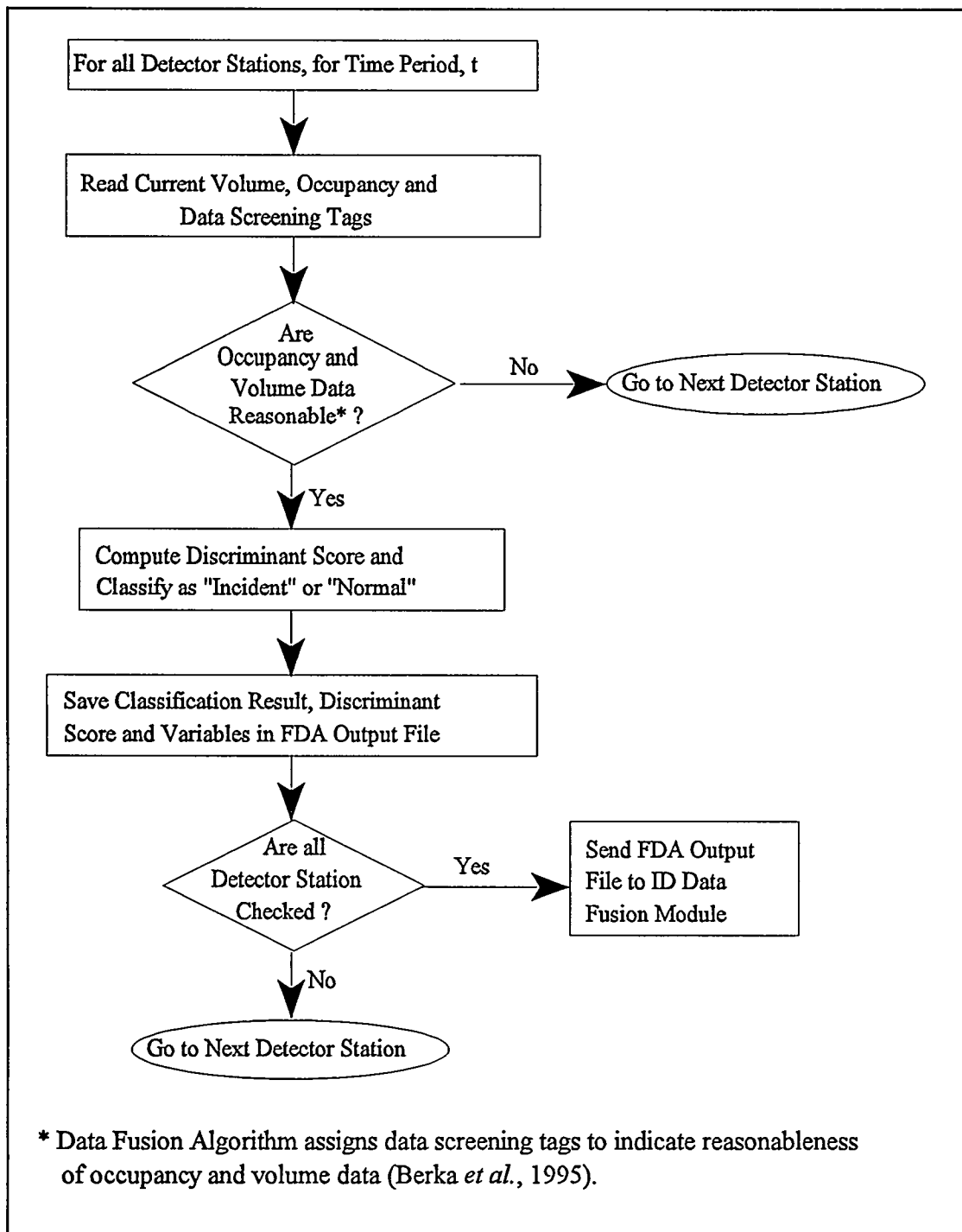

Figure 2.6: Flow Diagram for the Arterial Fixed Detector Algorithm

2.6 Summary of Arterial Fixed Detector Evaluation

The arterial fixed detector algorithm implemented in *ADVANCE* was evaluated for a period of two months at twenty-two locations along Dundee Road using detectors placed at approximately 90 meters upstream from major intersections which are located as much as 600 meters apart. Of 141 incidents reported during this period, the algorithm detected only seven incidents (and 32 incident periods) while also reporting nine false alarms. The mean time to detect was approximately five minutes after the first report received by local emergency services through Northwest Central Dispatch. These results were not improved through consideration of screening rules, evaluation by time of day, and incident type.

Consideration of alternative algorithms identified a change in specification, standardization of volume deviation and occupancy deviation by the variability of those measures at each station by time of day, which substantially improved the effectiveness of the arterial fixed detector algorithm. The revised algorithm was able to identify 29 of 141 incidents (and 86 incident periods) with no false alarms. The effectiveness of this revised algorithm was substantially better for major incidents (incidents not related to law enforcement); 18 of 71 (25%) major incidents detected vs. 11 of 70 (16%) of law enforcement incidents²². Of the incidents detected, close to half were detected before any report was received by local emergency services. These results indicate substantial potential for the development of arterial incident detection algorithms based on volume and occupancy data from fixed detectors. Stronger conclusions about the effectiveness of this algorithm require validation with a different

²² Detection of law enforcement incidents is of limited value since this information is available in a timely and reliable fashion through communication with local law enforcement agencies.

data set.

Field implementation of an arterial fixed detector algorithm should adopt conservative thresholds to ensure that the number of false alarms in application continues to be zero or very small. Ongoing data collection can be used to update the algorithm to account for both seasonal and long term changes in travel patterns.

3. PROBE VEHICLE ALGORITHM

3.1 Overview

The presence of an incident on a link is expected to increase travel time, reduce speed, of vehicles traversing that link as described in Section 2.1.1. Probe vehicles collect three data items describing each link traversal; these are travel time (number of seconds from the first second on the link to the first second on the next link), congestion distance (number of meters which the vehicle traveled at less than 10 meters per second) and congestion time (number of seconds during which the vehicle traveled at less than 2 meters per second) (De Leuw *et al.*, 1995).

The *ADVANCE* probe vehicle incident detection algorithm is based on link travel time and average link speed. Travel time and speed, measured during the current period, are compared to historic averages by taking differences or ratios. The probe vehicle algorithm (PVA) operates in two stages for each five minute period. The first stage computes the average travel times on links for which reports are available at the end of the time period. Aggregation of probe reports results in a more accurate representation of travel time conditions by reducing the potential to obtain a false alarm due to a single aberrant non-incident probe report. The second stage of the PVA applies the algorithm to classify conditions on links for which current data is available as "incident" or "normal".

Variables based on current travel time and its relationship to historic travel time were formulated and estimated based on simulated probe vehicle data. The measures considered included:

- (1) Travel Time Ratio: $TTRATIO[i,t] = TTOBS[i,t] / TTMEAN[i,t]$
- (2) Speed Ratio: $SPDRAT[i,t] = TTMEAN[i,t] / TTOBS[i,t];$
- (3) Travel Time Deviation: $TTNDEV[i,t] = (TTOBS[i,t] - TTMEAN[i,t]) / TTSD[i,t];$
- (4) Speed Deviation: $SPDDEV[i,t] = ((Link_Length/5280)/(TTOBS[i,t]/3600))$
 $-((Link_Length/5280)/(TTMEAN[i,t]/3600));$

where,

$TTOBS[i,t]$: observed average travel time on link i for time period t (in seconds),

$TTMEAN[i,t]$: historic travel time on link i for time period t (in seconds), and

$TTSD[i,t]$: standard deviation of historic travel time on link i for time period t (in seconds).

A discriminant function, $PV_DISC_FN[i,t]$, for the subject link i and time period t, is computed by

$$PV_DISC_FN[i,t] = \beta_0 + \beta_1 * TTRATIO[i,t] + \beta_2 * SPDRAT[i,t] + \beta_3 * TTNDEV[i,t] + \beta_4 * SPDDEV[i,t],$$

where the β coefficients depend on the number of reports used to compute the average travel time. The estimated parameters²³ for different models and the effective cut-off-points²⁴ for travel time ratio used to identify incidents are reported in Table 3.1. The parameter values reported in Table 3.1 indicate a high level of interdependence between β_0 and β_2 . However, the

²³ Parameter estimates are based exclusively on simulated data. Re-estimation with field data could not be undertaken due to unavailability of probe vehicles and delay in establishment of real time data linkage to NWCD for incident confirmation.

²⁴ Since the variables in the final model include time and speed ratio only, the effective cutoff between incident and non-incident conditions can be defined in terms of the travel time ratio.

important result of Table 3.1 is that the travel time ratio which indicates an incident is reduced in a consistent manner as the number of reports used to estimate the travel time increases. The algorithm for each link and time period is based on the number of vehicles for which data is available on the link during the time period.

Table 3.1 Estimated Parameters for Discriminant Function and Cut-off Points

| Number of reports | Parameter estimates for discriminant function | | | | | Travel time Ratio |
|-------------------|---|-----------|-----------|-----------|-----------|-------------------|
| | β_0 | β_1 | β_2 | β_3 | β_4 | |
| 1 | -9.5425 | 2.6628 | 0.7740 | 0.0 | 0.0 | 3.50 |
| 2 | -7.4920 | 2.2961 | -1.1592 | 0.0 | 0.0 | 3.45 |
| 3, 4, 5 | -8.1870 | 3.1157 | -1.4207 | 0.0 | 0.0 | 2.80 |
| 6, 7, 8 | -4.7278 | 2.4847 | -4.2547 | 0.0 | 0.0 | 2.60 |
| 8, ..., 15 | -4.4785 | 2.7365 | -4.8784 | 0.0 | 0.0 | 2.40 |
| 15, 16, ... | 26.1091 | -1.1258 | -35.4857 | 0.0 | 0.0 | 1.45 |

3.2 Field Data Collection

3.2.1 Procedure for Data Collection

The evaluation of the probe vehicle algorithm requires the collection of NWCD incident reports and probe data during incident and non-incident conditions.

Probe data under incident conditions were collected by assigning a deployed fleet of

vehicles in real time to an incident site within the NWCD jurisdictional area to acquire current link traversal data for the incident and adjacent links. The probe-equipped vehicles traversed the affected area as many times as possible to generate traversal data which was automatically broadcast to the TIC. The vehicles returned to the same site on subsequent days to collect data during non-incident conditions (during successive days when possible).

Planned construction evaluation was designed to make use of scheduled construction as a source of congestion to represent the impacts on traffic flow expected from short term incidents²⁵. Initial steps included identification of the locations and scheduled dates for planned construction within the *ADVANCE* test area, and the selection of at least four construction sites to be used for observation, with preference given to sites within the Dundee Rd. corridor. Probe vehicles were driven through construction links in the areas likely to be impacted by the construction. However, the long term nature of the construction projects prevented the collection of post-construction data at all but one site and, in that case, there was a three month gap between the construction and non-construction data collection. For these reasons, the construction evaluation was not undertaken.

²⁵ It was recognized that the use of construction as a proxy for an incident was limited due to the extent that driver awareness of the construction would result in route changes which reduce the traffic flow impact of the construction blockage.

3.2.2 Data Description

Data cover a total of twenty weekdays during August and November, 1995, from approximately 2 p.m. to 6 p.m. Incident data summary forms were used to record the NWCD log number, vehicles assigned and date and time of incident observed. Probe data included link travel time, congestion distance and congestion time for each traversal. Historic values for these variables were appended to each link traversal record.

3.3 Evaluation Results

3.3.1 Overview

The arterial probe vehicle incident detection algorithm is evaluated in terms of the number of incidents detected, the number of false alarms and the mean time to detect. The evaluation is undertaken separately for algorithms based on a single report and for sequences of three probe reports. A single report algorithm may be required in initial implementation of a probe vehicle algorithm as it is very unlikely to obtain two or more reports on a link during an incident period with low levels of fleet penetration. However, a single report algorithm has the potential for creating a large number of false alarms as it can be triggered when a single vehicle reports an unusually large travel time, possibly for a non-incident related reason. The three report algorithm is expected to provide more reliable incident detection because the effect of an extreme report will be offset by the more representative values of the other reports. In this evaluation, each sequence of three probe reports on a link is considered as an observation even if the time interval covered exceeds the nominal detection period to provide an indication of the potential effectiveness of a multiple report probe vehicle algorithm.

An incident is counted as detected if it is detected by the applicable algorithm at any time during the incident on the incident link (in either direction) or on one of the adjacent upstream or downstream links. A false alarm occurs if an incident is reported during any non-incident period on any of the links observed.

Examination of the probe data reports identified two data problems which required correction. The problems and the corrections applied to them are:

- The historic travel times for some traversals were unreasonable²⁶ and differed substantially from the average value for the observed non-incident traversals, which they were expected to represent. In these cases, the historic travel time was replaced by the average travel time for non-incident traversals.
- The probe report system is based on one-second monitoring of the vehicle location. A link traversal is considered to begin at the first one-second observation of a new link and to end at the first one-second observation on another link. However, some *ADVANCE* links, such as turning lanes or ramps, are so short that no one-second observation occurs on them for some traversals. Travel times on these "short links" are likely to be unavailable. In such cases, the "short link resolver" (De Leuw *et al.*, 1995) allocates the travel time between the short link and the adjacent upstream link. We found the resulting values for travel time, congestion distance and congestion time to be unreliable. To retain useful traversal information to the maximum extent possible, the traversal data for

²⁶ In some cases, the historic travel time implied a value of average link speed well outside the likely range of link speeds. The historic travel times were obtained from a network traffic flow model (Boyce *et al.*, 1994). In some cases, where the link was traversed many times the historic travel times were updated as part of the TRF Static Profile algorithm (Thakuriah *et al.*, 1994).

the pair of links was re-combined in these analyses.

3.3.2 Initial Evaluation Results

Detailed evaluation results for each of twenty²¹ incidents for which incident and non-incident data were available are reported in Appendix A which includes information describing the incident, probe traversal assignments, incident indicator scores for single and sets of three probe traversals and the interpretation of each probe traversal during both incident (incident detection or not) and non-incident (false alarm or not) conditions. A summary of this information for seventeen incidents²⁷ is reported in Tables 3.2a for severe incidents (accident with property damage and accident with personal injuries) and 3.2b for non-severe incidents (light malfunction, stalled truck/train and motorist assistance) where each incident is characterized by incident type and duration. The tables report the number of detections obtained by the algorithm relative to the number of traversals for the incident link and the adjacent upstream and downstream links during both incident and non-incident conditions for two directions of traffic flow²⁸. The results for each incident include one row where identification is based on single traversals and one row for three sequential traversals. For example, the first incident entries for Incident 1 indicate that six of nineteen traversals on the incident link in Direction 1 indicate the presence of an incident. Similarly, the next row indicates that seven of

²⁷ Four of the initially identified incidents were excluded because they occurred on links which were under construction during the incident day.

²⁸ The directions are arbitrarily designated as the direction of the incident lanes is not included in the incident descriptions.

fifteen sets of three traversals indicated the presence of an incident²⁹.

These results are further summarized in Table 3.3 which indicates the number of severe incidents, non-severe incidents and all incidents detected. These results indicate a good level

Table 3.2a Evaluation Results of Probe Vehicle Incident Detection Model

| Incidents Number and Types ³⁰ | Duration | Number of Reports | Incident Detections | | | | | | False Alarms | | | | | |
|--|----------|-------------------|---------------------|-------|-----------------|-------|-----------------|-------|----------------|-------|-----------------|-------|-----------------|-------|
| | | | Incident Links | | Up-stream Links | | Dn-stream Links | | Incident Links | | Up-stream Links | | Dn-stream Links | |
| | | | Dir.1 | Dir.2 | Dir.1 | Dir.2 | Dir.1 | Dir.2 | Dir.1 | Dir.2 | Dir.1 | Dir.2 | Dir.1 | Dir.2 |
| 1. ACPD | 72 | 1 | 6/19 | 0/14 | 0/8 | N/A | | | 0/58 | 0/43 | 0/22 | N/A | | |
| | | 3 | 7/15 | 0/8 | 0/6 | N/A | | | 0/54 | 0/39 | 0/20 | N/A | | |
| 2. ACPD/I | 53 | 1 | 0/3 | 0/1 | N/A | N/A | | | 0/20 | 0/5 | N/A | N/A | | |
| | | 3 | 0/1 | N/A | N/A | N/A | | | 0/18 | 0/3 | N/A | N/A | | |
| 4. ACPI | 93 | 1 | 1/2 | 0/2 | 0/1 | N/A | 0/3 | | 0/36 | 0/15 | 0/42 | N/A | 2/38 | |
| | | 3 | N/A | N/A | N/A | N/A | 0/1 | | 0/34 | 0/13 | 0/40 | N/A | 0/36 | |
| 7.ACPD | 39 | 1 | 0/4 | N/A | 0/2 | N/A | | | 0/23 | N/A | 0/41 | N/A | | |
| | | 3 | 0/2 | N/A | N/A | N/A | | | 0/21 | N/A | 0/39 | N/A | | |
| 8. ACPI | 51 | 1 | N/A | N/A | 0/2 | 0/1 | | | N/A | N/A | 0/6 | 0/6 | | |
| | | 3 | N/A | N/A | N/A | N/A | | | N/A | N/A | 0/4 | 0/4 | | |
| 9. ACPD | 61 | 1 | 1/3 | 0/1 | 0/1 | N/A | | | 0/4 | 0/2 | 0/3 | N/A | | |
| | | 3 | N/A | N/A | N/A | N/A | | | 0/1 | N/A | 0/1 | N/A | | |
| 13.ACPI | 79 | 1 | 4/6 | 0/2 | N/A | N/A | | | 0/61 | 0/25 | N/A | N/A | | |
| | | 3 | N/A | N/A | N/A | N/A | | | 0/55 | 0/23 | N/A | N/A | | |
| 14.ACPD | 78 | 1 | N/A | N/A | 0/5 | 1/5 | | | N/A | 0/3 | 0/15 | N/A | | |
| | | 3 | N/A | N/A | 0/3 | 0/3 | | | N/A | 0/1 | 0/13 | N/A | | |
| 17.ACPI | 59 | 1 | 1/3 | N/A | N/A | N/A | | | 0/18 | N/A | N/A | N/A | | |
| | | 3 | 1/1 | N/A | N/A | N/A | | | 0/16 | N/A | N/A | N/A | | |
| 20.ACPD | 84 | 1 | 0/2 | N/A | 0/2 | N/A | 2/2 | | 1/61 | N/A | 0/69 | N/A | 1/60 | |
| | | 3 | N/A | N/A | N/A | N/A | N/A | | 0/59 | N/A | 0/67 | N/A | 0/58 | |

²⁹ The number of sets of three sequential reports is equal to the number of single reports reduced by two for each turning movement.

³⁰ Incident types include accident with property damage (ACPD), accident with personal injuries (ACPI), light malfunction (LMAL), stalled train and truck, repair truck and motorist assistance.

Table 3.2b Evaluation Results of Probe Vehicle Incident Detection Model

| Incidents Number and Types | Duration | Number of Reports | Incident Detections | | | | | | False Alarms | | | | | |
|----------------------------|----------|-------------------|---------------------|-------|-----------------|-------|-----------------|-------|----------------|-------|-----------------|-------|-----------------|-------|
| | | | Incident Links | | Up-stream Links | | Dn-stream Links | | Incident Links | | Up-stream Links | | Dn-stream Links | |
| | | | Dir.1 | Dir.2 | Dir.1 | Dir.2 | Dir.1 | Dir.2 | Dir.1 | Dir.2 | Dir.1 | Dir.2 | Dir.1 | Dir.2 |
| 5.Stalled Train | 15 | 1 | 2/8 | 0/6 | 0/1 | 0/2 | | | 0/37 | 0/16 | 0/14 | 0/5 | | |
| | | 3 | 1/4 | 0/4 | N/A | N/A | | | 0/33 | 0/14 | 0/12 | 0/3 | | |
| 6. Repair Truck | 70 | 1 | 0/5 | 0/6 | 0/4 | 0/7 | | | 0/17 | 0/35 | 0/16 | 0/35 | | |
| | | 3 | 0/3 | 0/4 | 0/2 | 0/5 | | | 0/15 | 0/33 | 0/14 | 0/33 | | |
| 10.LMAL | 66 | 1 | 1/5 | 1/5 | 2/5 | N/A | 0/3 | | 0/7 | 0/7 | 0/7 | N/A | 0/7 | |
| | | 3 | 3/3 | 0/3 | 2/3 | N/A | 0/1 | | 0/5 | 0/5 | 0/5 | N/A | 0/5 | |
| 12.LMAL | 28 | 1 | 0/3 | 2/3 | N/A | N/A | 0/2 | | 0/32 | 0/46 | N/A | N/A | 0/42 | |
| | | 3 | 1/1 | 1/1 | N/A | N/A | N/A | | 0/30 | 0/44 | N/A | N/A | 0/40 | |
| 18.Stalled Truck | 30 | 1 | 2/8 | N/A | 2/8 | N/A | 0/2 | | 1/9 | N/A | 0/16 | N/A | 0/15 | |
| | | 3 | 2/6 | N/A | 1/6 | N/A | N/A | | 0/7 | N/A | 0/14 | N/A | 0/13 | |
| 19.Motorist Assistance | 25 | 1 | 2/2 | 0/1 | 0/3 | 0/1 | | | 0/63 | 0/64 | 0/89 | 0/70 | | |
| | | 3 | N/A | N/A | 0/1 | N/A | | | 0/61 | 0/62 | 0/87 | 0/68 | | |
| 21.LMAL | 105 | 1 | 3/3 | 0/7 | N/A | N/A | 0/7 | | 0/54 | 2/34 | N/A | N/A | 0/15 | |
| | | 3 | 1/1 | 0/5 | N/A | N/A | 0/5 | | 0/52 | 0/32 | N/A | N/A | 0/13 | |

Table 3.3 The Initial Evaluation of Probe Vehicle Incident Detection Algorithm

| Performance | Single Report ³¹ | | | Three Reports ³² | | |
|-----------------------------------|-----------------------------|------------|-------|-----------------------------|------------|-------|
| | Severe | Non-severe | Total | Severe | Non-severe | Total |
| # of Incidents | 8 | 7 | 15 | 4 | 7 | 11 |
| # of Incidents Detected | 6 | 5 | 11 | 2 | 4 | 6 |
| # of Incident Traversals | 94 | 107 | 201 | 40 | 58 | 98 |
| # of Incident Traversals Detected | 16 | 17 | 33 | 8 | 12 | 20 |
| # of False Alarms | -- ³³ | -- | 7 | -- | -- | 0 |
| DR (%) | 75.0 | 71.4 | 73.3 | 50.0 | 57.1 | 54.5 |
| FA (%) | 0.7 | 0.4 | 0.5 | 0.0 | 0.0 | 0.0 |

of incident detection for the algorithm based on single reports but with an unacceptably high false alarm rate. The corresponding data for the algorithm based on three sequential reports obtains a lower but still good detection rate with no false alarms. These results confirm that an algorithm based on single probe reports is likely to produce an unacceptably large number of

³¹ Incidents #8 and 14 were excluded from this table because no data was obtained on the incident links.

³² Four of eight severe incidents (4, 9, 13 and 20), which included fewer than three probe reports on the incident link, are excluded in assessment of the three report algorithm.

³³ False alarms are not disaggregated according to severity of the associated incidents as the condition during the false alarm period is unrelated to the incident other than by time of day and location.

false alarms³⁴. The results also indicate that while the primary detection of incidents occurs on the incident links, there is some potential to identify an incident on an adjacent upstream or downstream link. Finally, the algorithm appears to perform approximately as well for the types of incidents we classify as severe and the types we classify as not severe.

3.4 Modifications of Incident Detection Algorithms

Modification of the PVA was undertaken separately for the algorithm based on a single probe report and the algorithm based on three sequential probe reports. The model parameters for the single probe report case are estimated using field data for 13 incidents³⁵ and for the three probe report case using data for 11 incidents as in Table 3.3. The data files include probe reports on incident links and adjacent up- and down-stream links in each direction during both incident and non-incident conditions. In addition to the variables defined in section 3.1, the analysis includes the congestion distance deviation and ratio³⁶.

³⁴ A false alarm rate of 0.5% will result in large numbers of false alarms on even a small network.

³⁵ All incidents in Table 3.3 were included except for incidents 2 and 7 which are undetectable due to low travel time.

³⁶ The congestion distance ratio (CDRATIO) is the ratio of current to historic congestion distance. The congestion distance deviation (CDDEV) is the deviation of current to historic congestion distance. The congestion time was excluded from the analysis because it is missing on ten percent of the probe reports.

3.4.1 Model Estimations Using Single Reports

The estimation results of the PVA based on single reports are given in Table 3.4 including the discriminant function coefficients and performance measures for incidents detected³⁷, incident traversals classed as incidents³⁸ and non-incident traversals classified as incidents (false alarms). The first two models include travel time ratio without and with travel time deviation³⁹; the next two models add congestion distance deviation to these models. All four models detect the same number of incidents and produce approximately the same number of false alarms when tested with threshold equal to zero but the models with congestion distance deviation outperform the corresponding models with time variables only with respect to the number of incident traversals detected. The threshold for each of these models can be adjusted such that they do not produce any false alarms in this data set. When the thresholds are so adjusted, the simplest model with travel time ratio alone obtains the best incident results with nine of thirteen incidents and 17 of 76 incident traversals detected⁴⁰. Further, the thresholds for each of these models can be adjusted to an intermediate value with which the model outperforms the probe vehicle algorithm implemented in *ADVANCE* (more incidents and incident periods

³⁷ An incident is considered to be detected if one or more incident traversals (or sequences of three traversals in the case of the three report algorithm) are identified as incident traversals.

³⁸ A greater number of incident traversals identified provides higher assurance that the incident would be identified under condition of fewer probes operating.

³⁹ Models with travel time ratio with or without travel time deviation are consistently better than corresponding models with speed ratio with or without speed deviation and the addition of the speed related variables to models which include travel time related variables results in little or no improvement in classification so these variables are excluded from further consideration.

⁴⁰ Seventy-six traversals on incident, upstream and downstream links on which the traffic flow was impacted are used for model estimation.

detected and fewer false alarms).

Table 3.4 Probe Vehicle Detection Discriminant Parameters and Classification Performance Based on Single Reports

| Variables | | Model 1 | | Variables | | Model 2 | |
|-----------|--------------------|------------------------------|-------------------|-----------|--------------------|------------------------------|-------------------|
| TTRATIO | | 1.435 | | TTRATIO | | 0.972 | |
| Constant | | -4.240 | | TTDEV | | 0.008 | |
| | | | | Constant | | -3.789 | |
| Threshold | Incidents Detected | Incident Traversals Detected | # of False Alarms | Threshold | Incidents Detected | Incident Traversals Detected | # of False Alarms |
| 2.600 | 9 | 17 | 0 | 4.258 | 6 | 10 | 0 |
| 2.444 | 10 | 19 | 1 | 1.761 | 12 | 29 | 1 |
| 2.128 | 11 | 23 | 2 | 1.437 | 12 | 31 | 2 |
| 0 | 13 | 43 | 11 | 0 | 13 | 44 | 10 |

| Variables | | Model 3 | | Variables | | Model 4 | |
|-----------|--------------------|------------------------------|-------------------|-----------|--------------------|------------------------------|-------------------|
| TTRATIO | | 1.099 | | TTRATIO | | 0.903 | |
| CDDEV | | 0.005 | | TTDEV | | 0.004 | |
| Constant | | -4.125 | | CDDEV | | 0.004 | |
| | | | | Constant | | -3.889 | |
| Threshold | Incidents Detected | Incident Traversals Detected | # of False Alarms | Threshold | Incidents Detected | Incident Traversals Detected | # of False Alarms |
| 4.330 | 7 | 10 | 0 | 5.000 | 5 | 8 | 0 |
| 2.062 | 12 | 27 | 1 | 2.362 | 12 | 25 | 1 |
| 1.817 | 12 | 29 | 2 | 1.805 | 12 | 30 | 2 |
| 0 | 13 | 50 | 11 | 0 | 13 | 50 | 11 |

The effect on incident detection and false alarms of increasing the threshold can be seen in Figure 3.1 which shows the discriminant boundary and the individual traversal values for Model 3 (travel time ratio and congestion distance deviation) for the threshold set at zero and at 4.33 (no false alarms). Adjustment of the threshold is represented by "upward to the right" movement of the line without changing its slope. Traversals with data above the boundary for each threshold are classified as incidents for that threshold. The true incident characteristics are indicated by the symbols in the figure. Pluses are non-incident data and triangles represent incident traversals. The dark triangles represent the traversal with the highest score for each incident. It is apparent that, for Model 3 with threshold equal to zero, all the incidents are detected (13 dark triangle above the boundary) as well as a number of other incident traversals but with eleven false alarms. Using this algorithm, the number of false alarms can be reduced by increasing the threshold. As shown, increasing the threshold to 4.33 will eliminate all the false alarms but also eliminates a number of incident detections (dark triangles) and a number of secondary detections (open triangles). Recognizing that more extensive link coverage would result in many more non-incident traversals and many more false alarms, it would be appropriate to set the threshold at a value equal to or greater than the value which eliminates all false alarms in this data set (to reduce the possibility that additional false alarms will be generated in a general implementation). This figure can also be used to compare Model 3 with Model 1 represented by the horizontal dashed line. While Model 1 with zero false alarms identifies two additional incidents, its boundary is very close to a number of non-incident traversals which suggests a relatively high potential for false alarms in a larger data set. This suggests that it might be more appropriate to adopt Model 3 which has a slightly lower detection effectiveness

but also has a smaller potential for the generation of false alarms⁴¹.

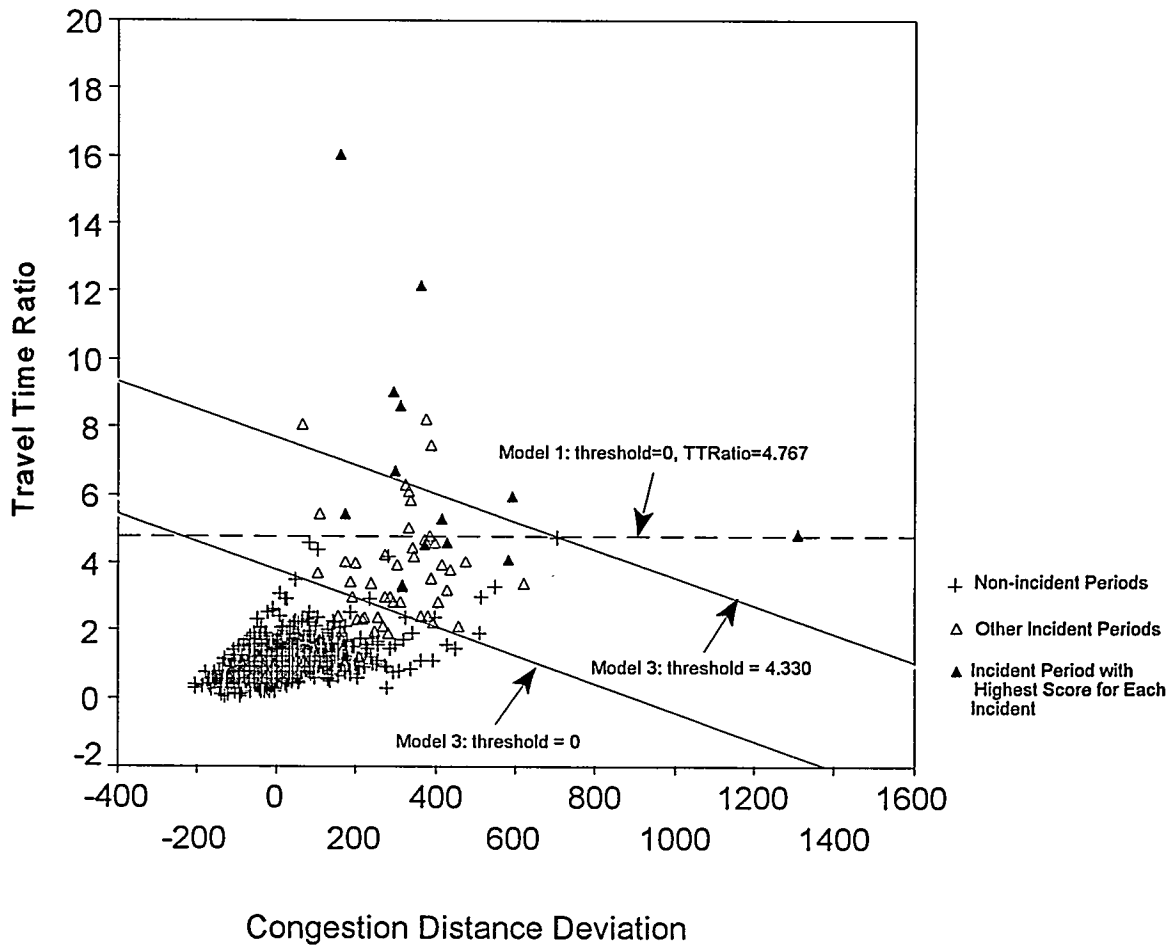

Figure 3.1: Effect of the Thresholds on the Single Report Model Results

⁴¹ A small number of false alarms in this small data set would suggest the potential for a huge number of false alarms for a representative data set including traversals on numerous links every day.

3.4.2 Model Estimations Using Three Reports

The estimation results of the PVA based on three probe reports using the same specifications as for the single probe report case are given in Table 3.5. All four models have identical incident classification results when compared with thresholds adjusted to eliminate all false alarms; they detect all of the incidents considered and 24 of 34 sequences of three probe reports selected for analysis⁴². These models perform better than the corresponding single probe report models as they detect all incidents but with fewer false alarms.

The advantages of Model 3 over Model 1 can be seen in Figure 3.2 which includes the threshold boundary which eliminates all false alarms in both cases. Using the threshold for Model 3 (solid line), one non-incident traversal (a potential false alarm) is close to the boundary, while for Model 1 (long dash line) a number of non-incident traversals are close to the boundary. This indicates that adoption of Model 1 would have a much larger potential for the generation of false alarms if it were implemented in a full scale deployment. These models can be compared to the model implemented in *ADVANCE* with Travel Time Ratio equal to 2.80 (short dashed line) which avoids false alarms but misses some incidents detected by the other algorithms.

⁴² Thirty-four sets of three traversals on incident, upstream and downstream links on which the traffic flow was impacted are used for model estimation.

Table 3.5 Probe Vehicle Detection Discriminant Parameters and Classification Performance Based on Three Reports

| Variables | | Model 1 | | Variables | | Model 2 | |
|-----------|--------------------|---------------------------|-------------------|-----------|--------------------|---------------------------|-------------------|
| TTRATIO | | 3.165 | | TTRATIO | | 2.721 | |
| Constant | | -7.198 | | TTDEV | | 0.007 | |
| | | | | Constant | | -6.687 | |
| Threshold | Incidents Detected | Incident Periods Detected | # of False Alarms | Threshold | Incidents Detected | Incident Periods Detected | # of False Alarms |
| 0 | 9 | 24 | 0 | 0.001 | 9 | 24 | 0 |
| -0.281 | 9 | 24 | 1 | 0 | 9 | 24 | 1 |
| -0.406 | 9 | 24 | 2 | -0.307 | 9 | 24 | 2 |

| Variables | | Model 3 | | Variables | | Model 4 | |
|-----------|--------------------|---------------------------|-------------------|-----------|--------------------|---------------------------|-------------------|
| TTRATIO | | 2.506 | | TTRATIO | | 2.368 | |
| CDDEV | | 0.006 | | TTDEV | | 0.002 | |
| Constant | | -6.625 | | CDDEV | | 0.006 | |
| | | | | Constant | | -6.550 | |
| Threshold | Incidents Detected | Incident Periods Detected | # of False Alarms | Threshold | Incidents Detected | Incident Periods Detected | # of False Alarms |
| 0.524 | 9 | 24 | 0 | 0.531 | 9 | 24 | 0 |
| 0 | 9 | 27 | 1 | 0 | 9 | 27 | 1 |
| -0.392 | 9 | 28 | 2 | -0.483 | 9 | 28 | 2 |

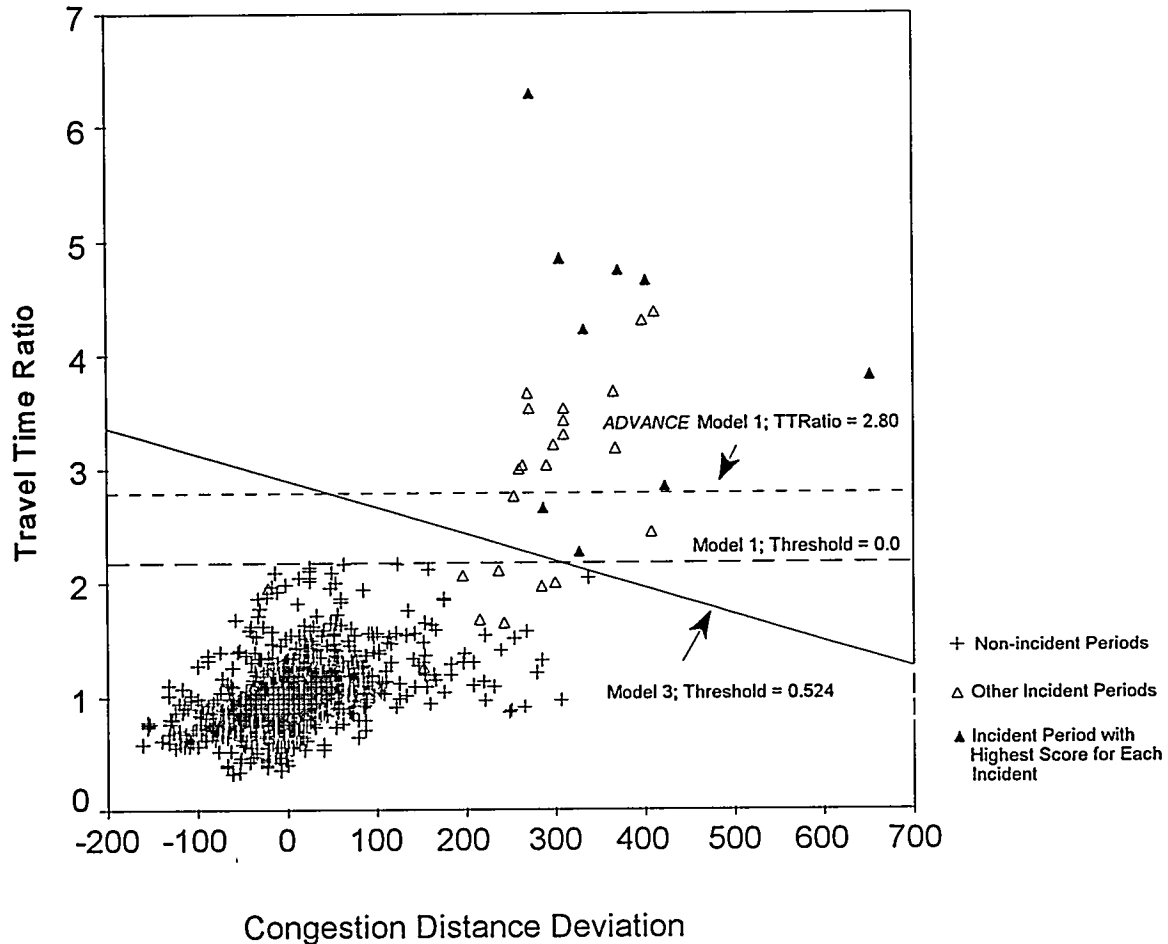

Figure 3.2: Effect of the Thresholds on the Three Report Model Results

3.4.3 Summary

During the early years of ITS deployment, the number of probe-equipped vehicles will be small and the TIC will receive very few reports per time period except for the most heavily travelled links. This paucity of probe data will encourage the use of a single probe report algorithm. While such an algorithm can be implemented, it is likely to detect only a small fraction of incidents if the threshold is set high enough to avoid a large number of false alarms.

These evaluation results indicate that a detection algorithm based on sequences of three or more probe reports will perform substantially better than one based on single reports.

The three report algorithm uses the travel time and congestion distance reported by probes to detect incidents. The model, based on the ratio of current to historic average travel times and the deviation of current to historic average congestion distances, obtained a high detection rate (100%) and a zero false alarm rate in this limited case.

It is essential to select a threshold which will ensure a very low false alarm rate because the field conditions in a large network will result in greater variability of travel times and congestion distances under non-incident conditions than that observed in our field experiment. We adopt a threshold which will result in no false alarms and a relatively small chance of generating false alarms with large field data and recognize that some fraction of incidents which have less severe traffic impacts are not likely to be detected. The resulting equation for the discriminant score is

$$PV_DISC_FN = -7.149 + 2.506 \times TTRATIO + 0.006 \times CDDEV$$

3.5 Implementation of the Revised Algorithm

The PVA requires current and historic probe vehicle data, and is designed to compute the averaged values of three reports each time. The historic data would be stored in the *ADVANCE* database 'Historic_Link_Data_Profile'. The current data would be provided to the incident detection module by 'TIC_Active_Data'. The parameters for the probe vehicle algorithm will be stored in the 'TRF_Data'.

The PVA operates in two stages. The first stage is the computation of the average travel

times and congestion distances on the links by aggregating three sequential probe reports each time. The second stage of PVA is the application of the algorithm to classify conditions on the links as "incident" or "normal". Figure 3.3 shows the flow diagram for the PVA. The steps in the algorithm are:

1. Obtain the current travel time and congestion distance for the link i at time t , if data is available. If not, go to the next link.
 - 1.1 Collect the current travel time and congestion distance for link i at time t .
 - 1.2 Compute the average travel time and congestion distance using current probe reports and probe reports for up to two previous periods if needed to obtain three probe reports.
2. Obtain the historic travel time and congestion distance for link i at time t .
 - 2.1 Collect the historic travel time and congestion distance for link i at time t .
 - 2.2 Compute the average historic travel time and congestion distance⁴³ on link i across all time periods for which probe data is included in step 1.
3. Compute the following variables:

$$TTRATIO[i,t] = TTOBS[i,t] / TTMEAN[i,t];$$

$$CDDEV[i,t] = (CDOBS[i,t] - CDMEAN[i,t]);$$

⁴³ The historic travel time and congestion distance associated with each probe report are fixed within time periods. However, in cases where sequential reports cross a major time period boundary (e.g., at 4 pm), the average provides a better representation of expected values.

where,

TTOBS[i,t]: Average three observed travel time on the link i at time t,

TTMEAN[i,t]: Average three historic travel time on the link i at time t,

CDOBS[i,t]: Average three observed congestion distance on the link i at time t,
and

CDMEAN[i,t]: Average three historic congestion distance on the link i at time
t.

4. Compute the discriminant function, PV_DISC_FN[i,t], for link i at time t as follows:

$$PV_DISC_FN[i,t] = \beta_0 + \beta_1 \times TTRATIO[i,t] + \beta_2 \times CDDEV[i,t]$$

where β_i s are:

$$\beta_0 = -7.149,$$

$$\beta_1 = 2.506,$$

$$\beta_2 = 0.006.$$

5. If $PV_DISC_FN[i,t] > 0$, an incident is flagged for the link i at time t, else the conditions are 'normal'.
6. Store the discriminant score, classification results and relevant explanatory variables, in a temporary file.
7. Repeat cycle for all links.
8. When all links are checked, pass the temporary file created in step 6 to ID data fusion module.

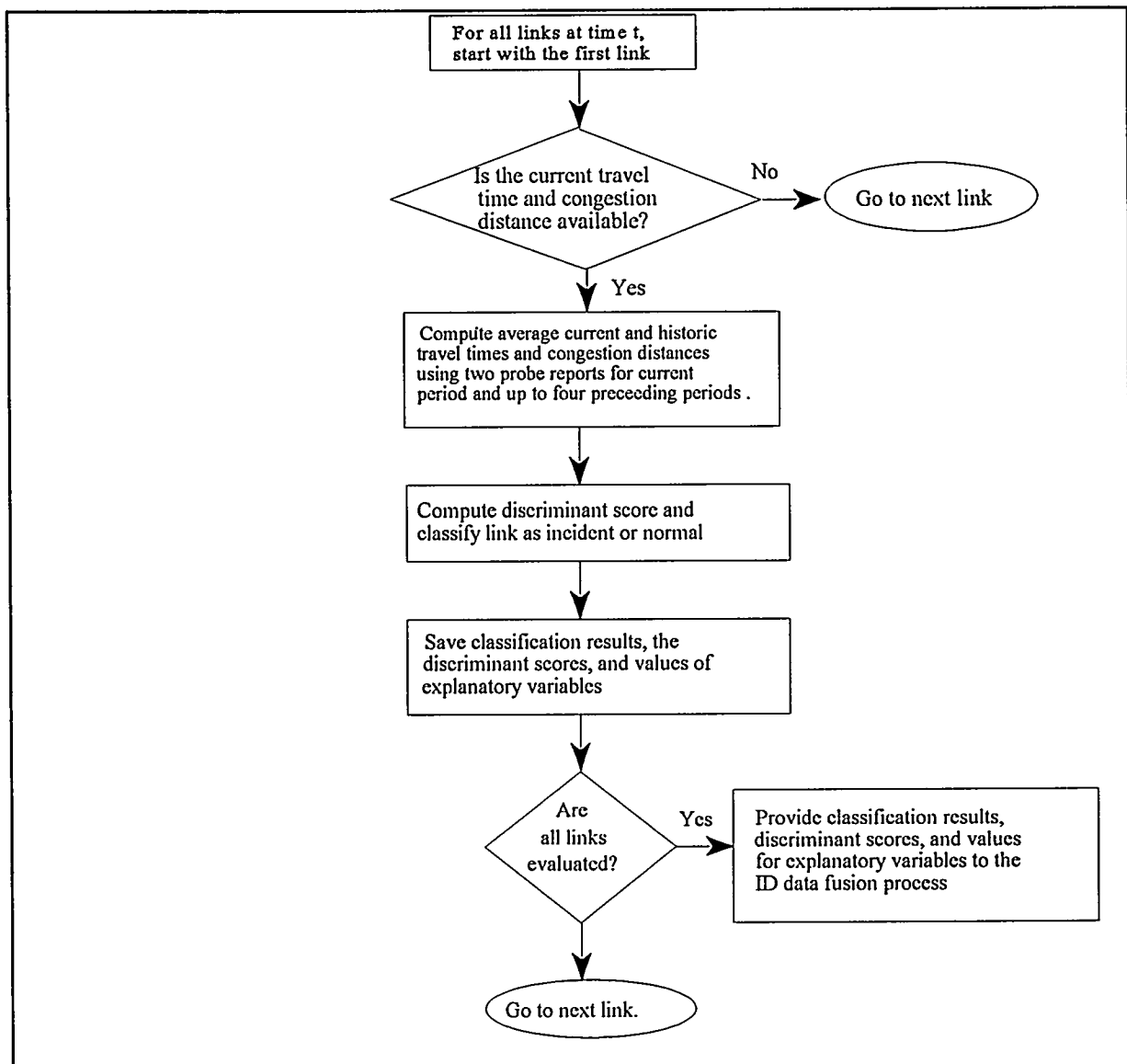

Figure 3.3: Flow Diagram for the Arterial Probe Vehicle Algorithm

3.6 Summary of Arterial Probe Vehicle Evaluation

The arterial probe vehicle algorithm implemented in *ADVANCE* was evaluated for a period of twenty days (ten days in August and ten days in November) within the *ADVANCE* area covered by Northwest Central Dispatch. Evaluation was based on the analysis of individual probe reports and sequences of three probe reports on the incident and adjacent links.

The single report algorithm identified eleven of fifteen incidents for which single reports were available but also produced seven false alarms. The three report algorithm identified six of eleven incidents for which sequences of three reports were available without any false alarms. These results favor the adoption of the three report algorithm over the single report algorithm. However, even the three report algorithm is likely to generate false alarms in a general implementation⁴⁴.

Consideration of alternative algorithms identified the potential to improve the three probe algorithm through a change in specification, addition of congestion distance deviation, which improved the effectiveness of the arterial fixed detector algorithm in terms of incident traversals identified and reduced potential of false alarms.

Both the evaluation and modification results support the contention that probe vehicle incident detection be based on the use of multiple reports to reduce the potential for numerous false alarms based on unusual readings from a single vehicle caused by reasons other than disruptions in traffic flow on a link.

⁴⁴ The number of false alarms is directly proportional to the size of the network and the number of days of operation. Given the variability of link travel time data, the result of no false alarms in this data set does not provide strong assurance that the number of false alarms would be small in a larger implementation.

Implementation of the probe vehicle arterial incident detection algorithm can only be expected to be successful if the number of vehicles equipped is large enough to ensure a reasonable likelihood of multiple probe vehicle reports on potential incident links during relatively short time periods during peak travel conditions. This might reasonably be accomplished if probe vehicles were 3-5% of the total fleet which would produce an average of 2.5 to 4 probe reports on arterial links for each five minute interval during peak periods.

4. EXPRESSWAY ALGORITHM

4.1 Overview

The Expressway ID Algorithm is based on the California Algorithm⁴⁵ which compares the value of variables derived from traffic measurements to pre-selected thresholds in a decision tree within which an incident is declared when the data conform to pre-selected criteria. These variables are:

- the spatial difference between downstream and upstream occupancy, OCCDF, which is calculated from occupancy at the upstream station, i , at time, t , and the occupancy at the downstream station, $i+1$, at the same time; that is $OCCDF_{i,t} = OCC_{i,t} - OCC_{i+1,t}$;
- the relative spatial difference between downstream and upstream occupancy, OCCRDF, which is the spatial difference in occupancy divided by the upstream occupancy; that is $OCCRDF_{i,t} = (OCC_{i,t} - OCC_{i+1,t}) / OCC_{i,t}$;
- the relative temporal difference in downstream occupancy, DOCCTD, which is calculated as the difference in downstream occupancy over two time periods relative to the downstream occupancy in the earlier time period; that is $DOCCTD_{i,t} = (OCC_{i+1,t-2} - OCC_{i+1,t}) / OCC_{i+1,t-2}$; and
- the downstream occupancy, DOCC, which is equal to $OCC_{i+1,t}$. Since DOCC has two different threshold values for different functions, it is shown as DOCC1 and DOCC2 in the algorithm.

⁴⁵ The California Algorithm (Payne *et al*, 1976) was selected by the *ADVANCE* project office.

The decision structure of the expressway incident detection algorithm is illustrated as a binary sequential decision tree (see Figure 4.1). The highest levels of the decision tree routes the algorithm to a series of tests depending on the current state (incident free, state 0; tentative incident, states 2 and 6; confirmed incident, state 7; terminated incident, state 1; or compression wave⁴⁶, states 3 to 5) of the expressway based on data in preceding time periods and the downstream occupancy.

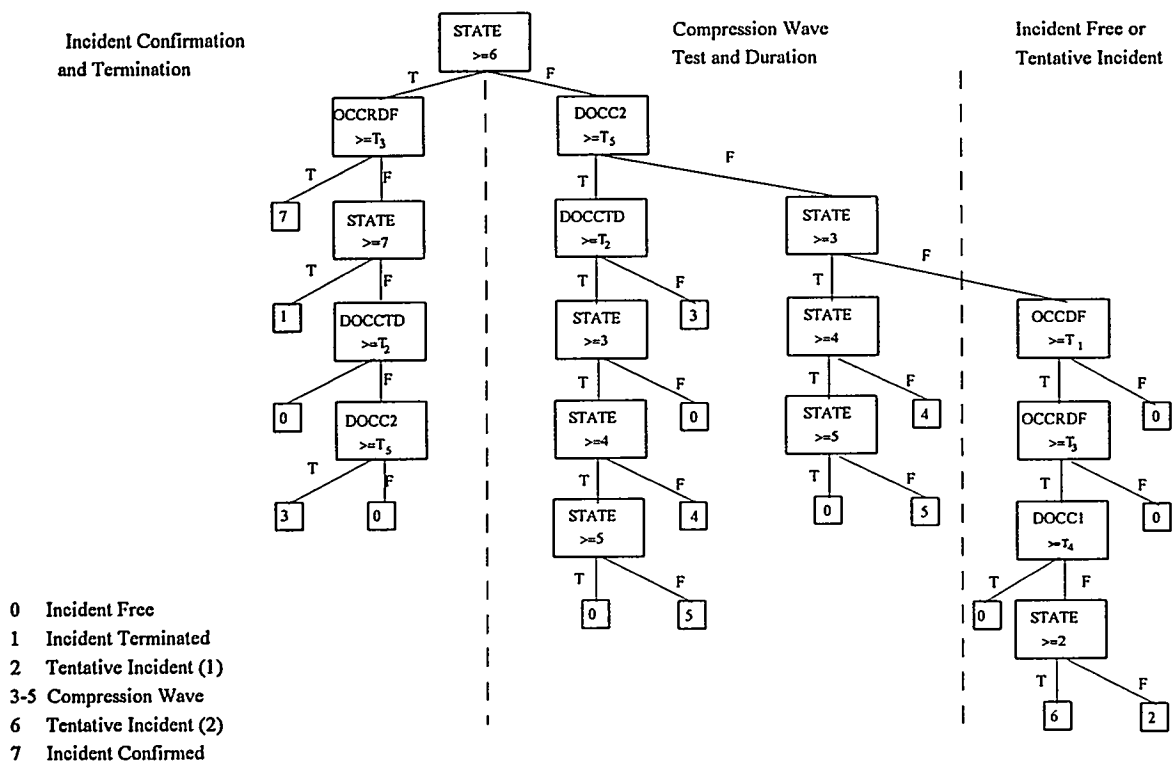

Figure 4.1 Decision Tree of Expressway Incident Detection Algorithm

⁴⁶ A compression or shock wave occurs when a queue forms upstream from an area of high congestion or reduced flow. The compression wave will propagate upstream at a rate depending on the speed and volume of traffic on the roadway. Thus, a compression wave on a road segment is indicated by an increase in occupancy at the downstream detector followed by an increase at the upstream detector.

The threshold values for the five criterion variables are chosen by using a single stage procedure in which the trade-off between increasing detection rate and increasing false alarm rate is selected a priori. The objective in this case can be thought of as trying to obtain a maximum detection rate adjusted by the weighted false alarm rate. An increasing weight implies a greater emphasis on avoiding false alarms. The thresholds for this algorithm were estimated using one minute reports of volume and occupancy and incident presence information for the Edens Expressway⁴⁷. These thresholds and the resultant detection and false alarm rates are shown in Table 4.1 for five different false alarm penalty weights.

Table 4.1 Estimation Thresholds and Results

| False Alarm Penalty Weight | Threshold Values | | | | | Detection Rate (%) | False Alarm Rate (%) |
|----------------------------|------------------|--------|--------|-------|-------|--------------------|----------------------|
| | OCCDF | DOCCTD | OCCRDF | DOCC1 | DOCC2 | | |
| 50 | 6.8 | -0.242 | 0.238 | 25.8 | 23.7 | 69.0 | 0.923 |
| 100 | 9.1 | -0.685 | 0.215 | 18.9 | 30.2 | 52.9 | 0.412 |
| 150 | 11.3 | -0.687 | 0.163 | 18.1 | 23.7 | 49.4 | 0.281 |
| 200 | 15.9 | -0.700 | 0.155 | 18.9 | 23.9 | 39.1 | 0.160 |
| 300 | 26.7 | -0.959 | 0.192 | 18.9 | 24.8 | 19.5 | 0.020 |

The structure of the decision tree can be understood best by considering its three primary functions: tentative incident identification, incident confirmation and termination and identification of compression waves. The first component tests for the existence of a

⁴⁷ The Edens Expressway is a 17-mile, six-lane, north-south expressway from the north side of Chicago (8 miles from the CBD) to Deerfield Rd in Highland Park.

compression wave (middle of Figure 4.1). A compression wave is declared when downstream occupancy is greater than its threshold, 24.8%⁴⁸, and downstream occupancy time difference is increasing rapidly, 95.9%. Once a compression wave has been declared, the algorithm maintains compression wave status for the next two one-minute periods; that is, the algorithm allows three minutes total for the compression wave to pass through the roadway segment defined by the station pair.

The second function, tentative incident identification (right side of Figure 4.1), is based on the values of the thresholds for spatial occupancy difference, OCCDF, relative spatial occupancy difference, OCCRDF, and downstream occupancy, DOCC1. A tentative incident will be identified when OCCDF is greater than 26.7% and OCCRDF is greater than 19.2% unless downstream occupancy is high enough, 18.9%, to indicate that any occupancy differences are due to downstream congestion. These criteria must be met for two sequential time periods before incident confirmation is considered.

The first function of the third component (left side of Figure 4.1), incident confirmation, occurs if the relative occupancy difference continues to be greater than its threshold for one additional period. If the incident is not confirmed, the algorithm either identifies a compression wave (under the same conditions described earlier for compression wave identification) or resets the state to the incident free condition. The second function of the third component terminates a confirmed incident when the relative occupancy difference, OCCRDF, drops below its threshold; that is, as soon as the difference between upstream and downstream occupancy drops

⁴⁸ Example values based on the most conservative model ($\alpha=300$) which emphasizes reduction in false alarms.

below 19.2% of the downstream occupancy.

The incident detection performance of the expressway algorithm was judged to be unsatisfactory due to the large number of expected false alarms compared to the expected number of successful incident detections. Despite this, the evaluation is undertaken to examine the transferability of the algorithm to a different context.

4.2 Evaluation Data

The computation of the Expressway Incident Detection Algorithm is based on one-minute reports for each station pair on the expressway considered. Each report includes the four variables defined in Section 4.1 from the fixed detector files and an incident indicator based on data from *999 and the Emergency Traffic Patrol. The evaluation data set includes data for the Kennedy Expressway⁴⁹ from O'Hare Airport to the Eisenhower Expressway, inbound, for peak periods⁵⁰ during the month of May. The incident data includes 87 non-disabled-vehicle incidents during peak periods. The non-incident data has been screened to include 35 hours of incident free peak period data for each station pair, compared to 184 hours of observed weekday peak period data.

⁴⁹ The Kennedy Expressway is a 16-mile, eight lane, expressway from downtown Chicago to O'Hare Airport.

⁵⁰ Peak periods are defined as 6:00 am to 10:00 am and 3:00 pm to 7:00 pm during weekdays.

4.3 Evaluation Results

The evaluation results reported in Table 4.2 report the number and rate of detections and the number and rate of false alarms using thresholds estimated from the Edens Expressway with different false alarm penalty weights. The number of detected incidents ranges from 17 (19.5%) to 60 (69.0%) of the 87 incidents in the data. The number of false alarms ranges from 18 (0.020%) to 814 (0.923%). Since the false alarms are estimated on the condensed incident free data, the number of false alarms should be multiplied by the ratio of incident free time (184 hours) to incident free time used in the estimation (35 hours) to get the expected number of false alarms in this roadway. This works out to 95 false alarms for the algorithm based on the highest false alarm penalty weight ($\alpha=300$) and 4279 false alarms for the algorithm estimated with the lowest penalty weight ($\alpha=50$). Clearly, these are unacceptably large numbers of false alarms.

Table 4.2: Evaluation Results of Kennedy Expressway, Inbound

| False Alarm Penalty Weight | Detection Rate (%) | Number of Detected Incident | False Alarm Rate (%) | Number of False Alarms | Mean Time To Detect (min.) |
|----------------------------|--------------------|-----------------------------|----------------------|------------------------|----------------------------|
| 50 | 69.0 | 60 | 0.923 | 814 | 11.15 |
| 100 | 52.9 | 46 | 0.412 | 363 | 11.76 |
| 150 | 49.4 | 43 | 0.281 | 248 | 12.88 |
| 200 | 39.1 | 34 | 0.160 | 141 | 12.59 |
| 300 | 19.5 | 17 | 0.020 | 18 | 13.29 |

Table 4.3 compares the evaluation results on the Kennedy Expressway evaluation data

set with the estimation results on the Edens Expressway data set. The detection rates in the evaluation test are lower and the false alarms are higher for the evaluation data than for the estimation data set (except for the fifth threshold set, alpha equals 300, for which the false alarm rates are approximately equal). The mean time to detect is approximately 1 or 2 minutes greater for the evaluation data than for the estimation data in every threshold set except for the fifth threshold set where it increases by about 1/2 minute.

Table 4.3: Comparison of Evaluation Results with Estimation Results

| Threshold Set | False Alarm Penalty Weight | Comparison | Detection Rate (%) | False Alarm Rate (%) | Mean Time to Detect (min.) |
|---------------|----------------------------|---------------------|--------------------|----------------------|----------------------------|
| 1 | 50 | Estimation(Edens) | 85.5 | 0.605 | 8.56 |
| | | Evaluation(Kennedy) | 69.0 | 0.923 | 11.15 |
| 2 | 100 | Estimation(Edens) | 63.8 | 0.209 | 10.89 |
| | | Evaluation(Kennedy) | 52.9 | 0.412 | 11.76 |
| 3 | 150 | Estimation(Edens) | 56.5 | 0.142 | 10.82 |
| | | Evaluation(Kennedy) | 49.4 | 0.281 | 12.88 |
| 4 | 200 | Estimation(Edens) | 49.3 | 0.094 | 10.74 |
| | | Evaluation(Kennedy) | 39.1 | 0.160 | 12.59 |
| 5 | 300 | Estimation(Edens) | 29.0 | 0.022 | 12.85 |
| | | Evaluation(Kennedy) | 19.5 | 0.020 | 13.29 |

Figure 4.2 shows the comparison of detection rates and false alarm rates between the estimation and evaluation results (the solid line connects the estimation points and the dotted line connects the evaluation observations; common numbers indicate pairs of points based on the same algorithm). It is apparent that the evaluation results are much worse than the estimation results (lower detection rate and/or higher false alarm rate in every case).

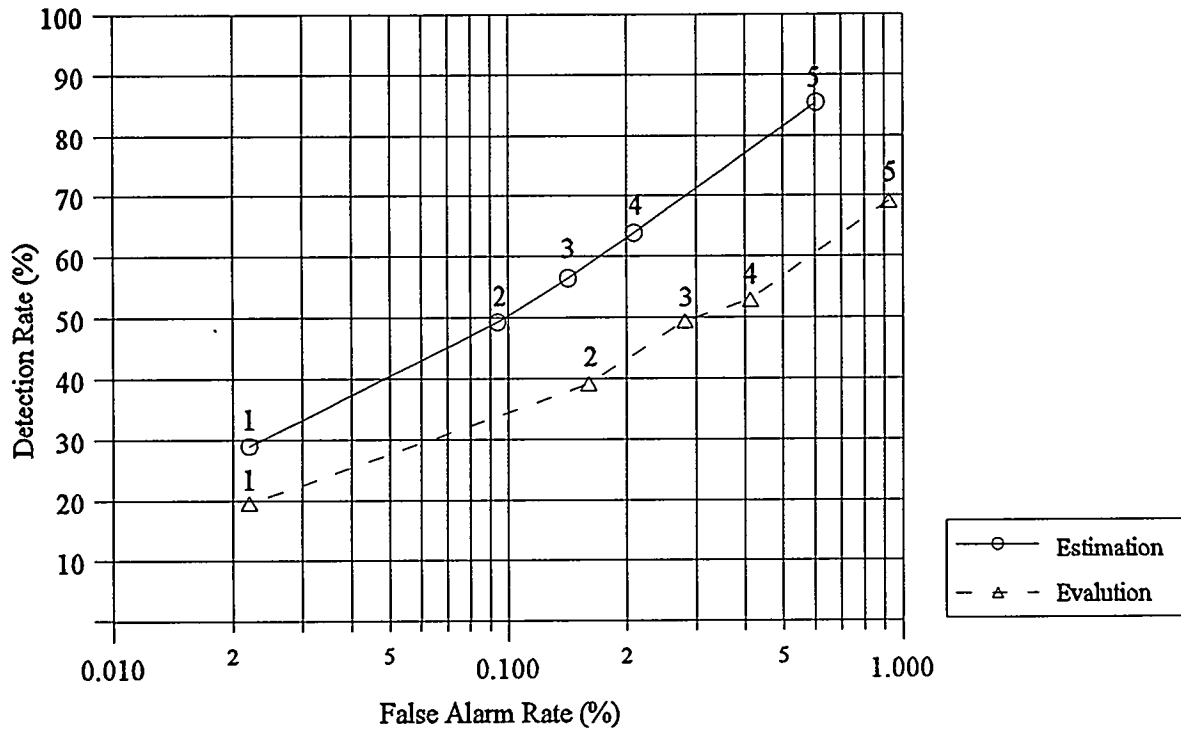

*The number above the symbol indicates the algorithm number.

Figure 4.2 Comparison of Evaluation Results with Estimation Results

There are two explanations for the differences between the estimation results of the original models on the Edens Expressway and the evaluation results obtained when applying these models to the Kennedy Expressway. These are (1) that it is more difficult to obtain good incident discrimination on the Kennedy Expressway than on the Edens Expressway and (2) that the model estimated on the Edens Expressway is not transferable to the Kennedy Expressway. The first explanation is that the characteristics of non-incident flow conditions are more similar to incident flow conditions on the Kennedy Expressway than on the Edens Expressway. This could result from higher levels of congestion on the Kennedy Expressway or/and from using data from a single detectorized lane to represent flow on four or five lanes on the Kennedy

Expressway compared to using a single detectorized lane to represent flow on three lanes on the Edens Expressway. The second explanation is that there are major differences in the best algorithm for the different expressways. That is, there is limited transferability of the estimated algorithm. Figure 4.2 shows the total difference between estimation on the Edens Expressway and application to the Kennedy Expressway; this difference includes both effects described above. Examination of Figure 4.3 indicates that a little more than half of this difference is attributable to the difference between roadways and the balance is attributable to differences in models.

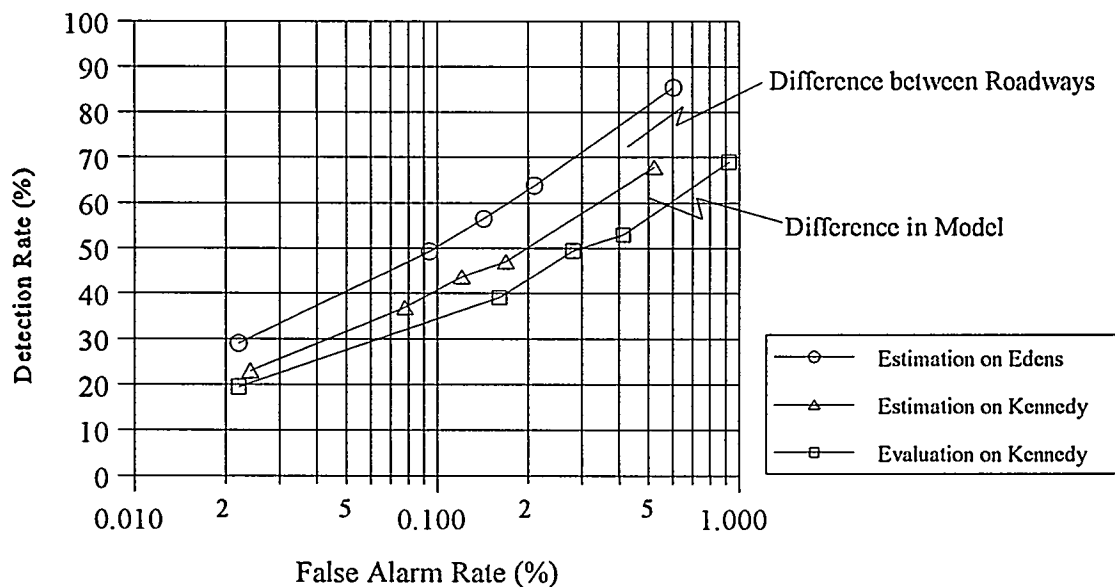

Figure 4.3 Comparison of Results: Estimation on Edens, Evaluation Application on Kennedy and Estimation on Kennedy

4.4 Summary of Expressway Incident Detection

The evaluation results obtained by applying the expressway incident detection algorithm on a new data set indicate that applying the algorithm to a different site causes a large drop in performance in terms of the detection rate, the false alarm rate, and the mean time to detect. The performance drop cannot be explained without substantial additional research; however, it appears to be due, in part, to the different traffic situation, including more congestion and more traffic lanes, on the evaluation roadway and, in part, to transfer between contexts indicating some lack of generalizability in algorithm parameters.

Both the estimation and evaluation results are unsatisfactory; that is, the number of false alarms generated by the algorithm is much greater than the number of incidents detected. These results indicate that great caution should be used in implementation of this automated incident detection algorithm in the absence of confirmation information from an independent source.

5. CONCLUSIONS

The incident detection component of *ADVANCE* was developed in the expectation that real time information will be valuable to all drivers in planning and executing selected travel routes. In particular, current information about the presence of incidents and their location will be valuable to local drivers, the primary users of *ADVANCE*, who are familiar with the network and have some knowledge of expected travel times under "normal conditions." This report describes the procedures and results of testing the effectiveness of arterial probe vehicle and fixed detector incident detection methods implemented in *ADVANCE* and expressway fixed detector incident detection methods considered for but not implemented in *ADVANCE*.

5.1 Evaluation of Arterial Incident Detection Using Fixed Detectors and Probe Vehicles

The *ADVANCE* incident detection system for arterial roads uses fixed detectors which provide occupancy and volume data, probe vehicles which provide link traversal data and anecdotal descriptions of events which are likely to impact traffic flow on arterial roads. For the purpose of evaluation, the anecdotal data provided by Northwest Central Dispatch (NWCD) is adopted as representing the true incident conditions of roadways in the portion of the *ADVANCE* area which is within emergency service jurisdictions supported by NWCD. The evaluation of both fixed detector and probe vehicle algorithms is undertaken by comparing arterial incidents identified by fixed detector and probe vehicle algorithms to incidents reported by NWCD. Additional analysis is undertaken to determine the extent to which modifications to the algorithms using evaluation data will improve their performance.

5.1.1 Evaluation of Arterial Fixed Detector Incident Detection Algorithm

The evaluation of the arterial fixed detector algorithm is undertaken by collecting data from loop detectors along Dundee Road and from NWCD logs for incident verification during a period of two months at twenty-two locations along Dundee Road. Of 141 incidents reported during this period, the algorithm detected only seven incidents (and 32 incident periods) while also reporting nine false alarms; the mean time to detect the detected incidents was approximately five minutes after the first report received by local emergency services through Northwest Central Dispatch. All of the detected incidents were incidents identified as major (not related to law enforcement). Consideration of alternative algorithms identified a change in specification, standardization of volume deviation and occupancy deviation by the variability of those measures at each station by time of day, which increased the number of detections to 29 including 18 major incidents and 86 incident periods without producing any false alarms. The mean time to detect is approximately equal to the time of the first NWCD report and close to half of the detected incidents were detected before any report was received by local emergency services.

These results indicate substantial potential for the development of arterial incident detection algorithms based on data from fixed detectors. A first step toward realization of this result would be more extensive data collection and analysis of arterial detector data in a variety of environments with corresponding incident verification data.

5.1.2 Evaluation of Arterial Probe Vehicle Incident Detection Algorithm

The evaluation of the probe vehicle algorithm is based on comparison of link traversal data collected through the assignment of a fleet of vehicles to travel on incident links under incident and non-incident conditions to NWCD logs for incident verification.

The arterial probe vehicle algorithm implemented in *ADVANCE* was evaluated for a period of twenty days (ten days in August and ten days in November, 1995) within the *ADVANCE* area covered by Northwest Central Dispatch. Evaluation was based on the analysis of individual probe reports and sequences of three probe reports on the incident and adjacent links.

The three report algorithm identified six of eleven incidents, for which sequences of three reports were available, without any false alarms; the corresponding single report algorithm was not capable of detecting this share of incidents without reporting multiple false alarms.

An alternative algorithm which changed the specification by the addition of congestion distance deviation improved the effectiveness of the arterial fixed detector algorithm in terms of the number of incident traversals identified and the number of false alarms.

Both the evaluation and modification results support the contention that probe vehicle incident detection be based on the use of multiple reports to avoid the potential for numerous false alarms based on unusual readings from a single vehicle caused by reasons other than disruptions in traffic flow on a link.

Implementation of the probe vehicle arterial incident detection algorithm can only be expected to be successful if the number of vehicles equipped is large enough to ensure a reasonable likelihood of multiple probe vehicle reports on potential incident links during

relatively short time periods during peak travel conditions. Further development of the potential for incident identification through the use of probe vehicles would require a larger field test.

5.2 Expressway Incident Detection

Limited development of an incident detection capability for expressways in the *ADVANCE* and adjacent areas was based on the California incident detection algorithm using data from fixed detectors which are located at approximately one-half mile intervals for the center lane of each roadway. The estimated algorithm was unsatisfactory as the number of false alarms was much greater than the number of incidents detected at any reasonable level of detection. Nonetheless, this algorithm is included in the evaluation for completeness.

The evaluation of the expressway incident detection algorithm was undertaken by collecting automatic data from loop detectors along a different expressway and comparing incident detection results to incident confirmation data based on cellular phone and Emergency Traffic Patrol reports.

The evaluation results obtained by applying the expressway incident detection algorithm on a new data set indicate that applying the algorithm to a different site causes a large drop in performance in terms of the detection rate, the false alarm rate, and the mean time to detect. The performance drop is due, in part, to the different traffic situation, including more congestion and more traffic lanes, on the evaluation roadway and, in part, to transfer between contexts indicating some lack of generalizability in algorithm parameters.

Both the estimation and evaluation results are unsatisfactory; they indicate that the number of false alarms generated by the algorithm is likely to be much greater than the number

of incidents detected. These results indicate that great caution should be used in implementation of this automated incident detection algorithm in the absence of confirmation information from an independent source. This unsatisfactory performance compared to reported incident detection performance in other contexts may be due to limitations in the precision and completeness of incident information and reliance on single lane detectors rather than multiple lane detectors.

5.3 Conclusion

The results of this evaluation indicate a potential to develop and implement effective incident detection capabilities for use on arterial road networks based on either or both of fixed detector or probe vehicle data. However, considerable additional development, with field data is required to reach this potential.

References

- Berka S., Tian X., and Tarko A., (1995), "Data fusion algorithm for *ADVANCE* Release 2.0," *ADVANCE Tasks TRF-DF-202/204*, May.
- Bhandari N., Sethi V., Koppelman F.S., and Schofer J.L., (1995), "Calibration of fixed detector and probe vehicle algorithms with initial field data," *ADVANCE Project Technical Report TRF-ID-201*, Northwestern University, Evanston, IL, (rev.) March 17.
- Boyce D.E., Tarko A., Berka S., and Zhang Y., (1994), "Estimation of link travel times with a large-scale network flow model for a dynamic route guidance system," *Paper presented at Fourth Annual Meeting of IVHS America*, Atlanta, Georgia, April 18.
- De Leuw, Cather and Company, (1995), "*ADVANCE* interface control specification," *ADVANCE Document#8110.ADV.05-2.0*.
- Green B.F., (1979), "The two kinds of linear discriminant functions and their relationship," *Journal of Educational Statistics*, 4:3, 247-263.
- Klecka W.R., (1980), *Discriminant Analysis*, Sage University Paper Series, Quantitative Applications in the Social Sciences, no. 07-019, Beverly Hills, CA, Sage Publications.
- Koppelman F.S., Schofer J.L., Bhandari N., Sethi V., and Ivan J.N., (1994), "Calibration of fixed detector and probe vehicle algorithms using simulated data," *ADVANCE Project Technical Report ADV-ID-151*, Northwestern University, Evanston, IL, (rev.)
- Koppelman F.S., and Tsai S., (1995), "Revised incident detection algorithms for release 2.0 and re-calibration of arterial fixed detector incident detection parameters," *ADVANCE Project Technical Report TRF-ID-300/400*, Northwestern University, Evanston, IL, August 3.
- Koppelman F.S., and Lin W., (1996), "Development of an expressway incident detection algorithm for the *ADVANCE* area based on the California algorithms," *ADVANCE Project Technical Report TRF-ID-311/312*, Northwestern University, Evanston, IL, March 29.
- Norusis M.J., (1988), *SPSS/PC+ advanced statistics V2.0*, Chicago, IL, SPSS Inc.
- Payne H.J., Helfenbein E.D., and Knobel H.C., (1976), *Development and testing of incident detection algorithms, vol 2, research methodology and detailed results, Report no. FHWA-RD-76-20*, Federal Highway Administration, Washington D.C.
- Sethi, V., Bhandari N., Koppelman F.S., and Schofer J.L., (1995), "Arterial Incident Detection Using Fixed Detector and Probe Vehicle Data," *Transportation Research Part C*, Vol.3,

No.2, pp.99-112.

Sisiopiku V., Roupail N.M., and Santiago A., (1994), "Analysis of the correlation between arterial travel times and detector data from simulation and field studies," *Transportation Research Record*, No. 1457, p. 166-173.

Thakuriah P., Sen A., and Mathes M., (1994), "Static estimates of travel times in *ADVANCE*, Release 1.6", *ADVANCE Working Paper #39*.

Appendix A: Detailed Probe Vehicle Evaluation Results

| | |
|---|--|
| NU Inc. #: <u>1</u> | NWCD Incident #: <u>AHP9534421</u> |
| Date: <u>08/09/95</u> | First report: <u>15:49</u> Clear: <u>17:01</u> |
| Type: <u>ACPD</u> | Inc. Location: <u>WB Rand, btw Wilke & Hintz</u> |
| Incident PV IDs: <u>41</u> , <u>0A</u> , _____, _____ | |
| Follow-up PV IDs: Date: <u>08/21</u> ; <u>41</u> , <u>10</u> , <u>15</u> , <u>2B</u> Date: <u>08/23</u> ; <u>0A</u> , <u>1B</u> , _____, _____ Date: <u>08/24</u> ; <u>23</u> , <u>57</u> , <u>2B</u> , _____ Date: <u>08/25</u> ; <u>5C</u> , <u>59</u> , _____, _____ Date: <u>11/15</u> ; <u>16</u> , _____, _____, _____ | |
| Use distinct block for each link (and turning movement) | |
| Segment #: <u>88d070-88d0ac</u> Direction: <u>SEB</u> | |
| Link Location: (Incident, Upstream, Downstream): <u>INC</u> Turn: <u>Through</u> | |
| Inc. Detections/Traversals: Base (1 report): <u>0/8</u> ; FU Alarms/Traversals: <u>0/21</u> Base (3 report): <u>0/6</u> ; FU Alarms/Traversals: <u>0/19</u> Adj. (1 report): _____ ; FU Alarms/Traversals: _____ Adj. (3 report): _____ ; FU Alarms/Traversals: _____ | |
| Other observations (Short link, data problems, etc.; use lines as needed) | |
| Segment #: <u>88d0ac-88d226</u> Direction: <u>SEB</u> | |
| Link Location: (Incident, Upstream, Downstream): <u>INC</u> Turn: <u>Turn</u> | |
| Inc. Detections/Traversals: Base (1 report): <u>0/4</u> ; FU Alarms/Traversals: <u>N/A</u> Base (3 report): <u>0/2</u> ; FU Alarms/Traversals: _____ Adj. (1 report): _____ ; FU Alarms/Traversals: _____ Adj. (3 report): _____ ; FU Alarms/Traversals: _____ | |
| Other observations (Short link, data problems, etc.; use lines as needed): <u>No FU traversals.</u> | |
| Segment #: <u>88d0ac-88d2d0</u> Direction: <u>SEB</u> | |
| Link Location: (Incident, Upstream, Downstream): <u>INC</u> Turn: <u>Through</u> | |
| Inc. Detections/Traversals: Base (1 report): <u>0/2</u> ; FU Alarms/Traversals: <u>0/22</u> Base (3 report): _____ ; FU Alarms/Traversals: <u>0/20</u> Adj. (1 report): <u>0/2</u> ; FU Alarms/Traversals: <u>0/22</u> Adj. (3 report): _____ ; FU Alarms/Traversals: <u>0/20</u> | |
| Other observations (Short link, data problems, etc.; use lines as needed) | |

| | |
|---|--|
| NU Inc. #: <u> 1 </u> | NWCD Incident #: <u> AHP9534421 </u> |
| Date: <u> 08/09/95 </u> | First report: <u> 15:49 </u> Clear: <u> 17:01 </u> |
| Type: <u> ACPD </u> | Inc. Location: <u> WB Rand, btw Wilke & Hintz </u> |
| Segment #: <u> 8a1044-8ce5c8 </u> Direction: <u> SEB </u> Link Location: (Incident, Upstream, Downstream): <u> UP1 </u> Turn: <u> Through </u> Inc. Detections/Traversals: Base (1 report): <u> 0/8 </u> ; FU Alarms/Traversals: <u> 1/22 </u> Base (3 report): <u> 0/6 </u> ; FU Alarms/Traversals: <u> 0/20 </u> Adj. (1 report): <u> 0/8 </u> ; FU Alarms/Traversals: <u> 0/22 </u> Adj. (3 report): <u> 0/6 </u> ; FU Alarms/Traversals: <u> 0/20 </u> Other observations (Short link, data problems, etc.; use lines as needed) | |
| Segment #: <u> 8d070-a1044 </u> Direction: <u> NWB </u> Link Location: (Incident, Upstream, Downstream): <u> INC </u> Turn: <u> Through </u> Inc. Detections/Traversals: Base (1 report): <u> 2/9 </u> ; FU Alarms/Traversals: <u> 6/31 </u> Base (3 report): <u> 0/7 </u> ; FU Alarms/Traversals: <u> 3/29 </u> Adj. (1 report): <u> 0/9 </u> ; FU Alarms/Traversals: <u> 0/31 </u> Adj. (3 report): <u> 0/7 </u> ; FU Alarms/Traversals: <u> 0/29 </u> Other observations (Short link, data problems, etc.; use lines as needed) | |
| Segment #: <u> 8d0ac-8d070 </u> Direction: <u> NWB </u> Link Location: (Incident, Upstream, Downstream): <u> INC </u> Turn: <u> Through </u> Inc. Detections/Traversals: Base (1 report): <u> 1/10 </u> ; FU Alarms/Traversals: <u> 0/27 </u> Base (3 report): <u> 3/8 </u> ; FU Alarms/Traversals: <u> 0/25 </u> Adj. (1 report): <u> 6/10 </u> ; FU Alarms/Traversals: <u> 0/27 </u> Adj. (3 report): <u> 7/8 </u> ; FU Alarms/Traversals: <u> 0/25 </u> Other observations (Short link, data problems, etc.; use lines as needed) | |

| | |
|---|--|
| NU Inc. #: <u> 2 </u> | NWCD Incident #: <u> EGP9535364 (EGP 9535374) </u> |
| Date: <u> 08/09/95 </u> | First report: <u> 15:12 (16:18) </u> Clear: <u> 16:05 (17:09) </u> |
| Type: <u> ACPD/I </u> | Inc. Location: <u> NB Elmhurst, btw Landmeier & Higgins </u> |
| Incident PV IDs: <u> 59 </u> , <u> 09 </u> , <u> </u> , <u> </u> | |
| Follow-up PV IDs: | |
| Date: <u> 08/21 </u> ; | <u> 0A </u> , <u> 09 </u> , <u> 17 </u> , <u> 57 </u> |
| Date: <u> 08/22 </u> ; | <u> 59 </u> , <u> </u> , <u> </u> , <u> </u> |
| Date: <u> 08/23 </u> ; | <u> 50 </u> , <u> 14 </u> , <u> </u> , <u> </u> |
| Date: <u> 08/24 </u> ; | <u> 17 </u> , <u> 15 </u> , <u> </u> , <u> </u> |
| Date: <u> 08/25 </u> ; | <u> 15 </u> , <u> 0A </u> , <u> </u> , <u> </u> |
| Date: <u> 11/07 </u> ; | <u> 09 </u> , <u> 52 </u> , <u> </u> , <u> </u> |
| Use distinct block for each link (and turning movement) | |
| Segment #: <u> 89e584-90c0e </u> Direction: <u> SB </u> | |
| Link Location: (Incident, Upstream, Downstream): <u> INC </u> Turn: <u> Turn </u> | |
| Inc. Detections/Traversals: | |
| Base (1 report): <u> 0/1 </u> ; | FU Alarms/Traversals: <u> 0/5 </u> |
| Base (3 report): <u> </u> ; | FU Alarms/Traversals: <u> 0/3 </u> |
| Adj. (1 report): <u> 0/1 </u> ; | FU Alarms/Traversals: <u> 0/5 </u> |
| Adj. (3 report): <u> </u> ; | FU Alarms/Traversals: <u> 0/3 </u> |
| Other observations (Short link, data problems, etc.; use lines as needed): | |
| Segment #: <u> 89e584-90cf3 </u> Direction: <u> SB </u> | |
| Link Location: (Incident, Upstream, Downstream): <u> INC </u> Turn: <u> Through </u> | |
| Inc. Detections/Traversals: | |
| Base (1 report): <u> 0/1 </u> ; | FU Alarms/Traversals: <u> </u> |
| Base (3 report): <u> </u> ; | FU Alarms/Traversals: <u> </u> |
| Adj. (1 report): <u> </u> ; | FU Alarms/Traversals: <u> </u> |
| Adj. (3 report): <u> </u> ; | FU Alarms/Traversals: <u> </u> |
| Other observations (Short link, data problems, etc.; use lines as needed): <u> No FU traversals. </u> | |
| Segment #: <u> 9e584-908b7 </u> Direction: <u> NB </u> | |
| Link Location: (Incident, Upstream, Downstream): <u> INC </u> Turn: <u> Through </u> | |
| Inc. Detections/Traversals: | |
| Base (1 report): <u> 0/3 </u> ; | FU Alarms/Traversals: <u> 2/20 </u> |
| Base (3 report): <u> 0/1 </u> ; | FU Alarms/Traversals: <u> 3/18 </u> |
| Adj. (1 report): <u> 0/3 </u> ; | FU Alarms/Traversals: <u> 0/20 </u> |
| Adj. (3 report): <u> 0/1 </u> ; | FU Alarms/Traversals: <u> 0/18 </u> |
| Other observations (Short link, data problems, etc.; use lines as needed) | |

| | |
|---|--|
| NU Inc. #: <u> 2 </u> | NWCD Incident #: <u> EGP9535364 (EGP 9535374) </u> |
| Date: <u> 08/09/95 </u> | First report: <u> 15:12 (16:18) </u> Clear: <u> 16:05 (17:09) </u> |
| Type: <u> ACPD/I </u> | Inc. Location: <u> NB Elmhurst, btw Landmeier & Higgins </u> |
| Segment #: <u> 890cf3-89e59a </u> Direction: <u> NB </u> Link Location: (Incident, Upstream, Downstream): <u> UP1 </u> Turn: <u> Turn </u> Inc. Detections/Traversals: Base (1 report): <u> N/A </u> ; FU Alarms/Traversals: <u> N/A </u> Base (3 report): <u> </u> ; FU Alarms/Traversals: <u> </u> Adj. (1 report): <u> </u> ; FU Alarms/Traversals: <u> </u> Adj. (3 report): <u> </u> ; FU Alarms/Traversals: <u> </u> Other observations (Short link, data problems, etc.; use lines as needed): <u> No CTT, no FU traversals. </u> | |
| Segment #: <u> 9e59a-9e584 </u> Direction: <u> WB </u> Link Location: (Incident, Upstream, Downstream): <u> UP1 </u> Turn: <u> Through </u> Inc. Detections/Traversals: Base (1 report): <u> 0/1 </u> ; FU Alarms/Traversals: <u> N/A </u> Base (3 report): <u> </u> ; FU Alarms/Traversals: <u> </u> Adj. (1 report): <u> </u> ; FU Alarms/Traversals: <u> </u> Adj. (3 report): <u> </u> ; FU Alarms/Traversals: <u> </u> Other observations (Short link, data problems, etc.; use lines as needed): | |

| | |
|--|--|
| NU Inc. #: <u> 3 </u> | NWCD Incident #: <u> None </u> |
| Date: <u> 08/09/95 </u> | First report: <u> 15:27 </u> Clear: <u> 16:15 </u> |
| Type: <u> Short Term Cons. </u> | Inc. Location: <u> WB Central, Central & Arlington Hts. </u> |
| Incident PV IDs: <u> 41 </u> , <u> </u> , <u> </u> , <u> </u> | |
| Follow-up PV IDs: Date: <u> </u> ; <u> </u> , <u> </u> , <u> </u> , <u> </u> Date: <u> </u> ; <u> </u> , <u> </u> , <u> </u> , <u> </u> Date: <u> </u> ; <u> </u> , <u> </u> , <u> </u> , <u> </u> Date: <u> </u> ; <u> </u> , <u> </u> , <u> </u> , <u> </u> | |
| Use distinct block for each link (and turning movement) | |
| Segment #: <u> 8ee4-8ee90 </u> Direction: <u> WB </u> Link Location: (Incident, Upstream, Downstream): <u> UP1 </u> Turn: <u> Through </u> Inc. Detections/Traversals: Base (1 report): <u> 0/3 </u> ; FU Alarms/Traversals: <u> </u> Base (3 report): <u> 0/1 </u> ; FU Alarms/Traversals: <u> </u> Adj. (1 report): <u> </u> ; FU Alarms/Traversals: <u> </u> Adj. (3 report): <u> </u> ; FU Alarms/Traversals: <u> </u> Other observations (Short link, data problems, etc.; use lines as needed) | |
| Segment #: <u> 8ee90-8eb93 </u> Direction: <u> WB </u> Link Location: (Incident, Upstream, Downstream): <u> Cons. Side </u> Turn: <u> </u> Inc. Detections/Traversals: Base (1 report): <u> 0/3 </u> ; FU Alarms/Traversals: <u> </u> Base (3 report): <u> 0/1 </u> ; FU Alarms/Traversals: <u> </u> Adj. (1 report): <u> </u> ; FU Alarms/Traversals: <u> </u> Adj. (3 report): <u> </u> ; FU Alarms/Traversals: <u> </u> Other observations (Short link, data problems, etc.; use lines as needed) | |
| Segment #: <u> 8ee82-8ee87 </u> Direction: <u> WB </u> Link Location: (Incident, Upstream, Downstream): <u> DN2 </u> Turn: <u> </u> Inc. Detections/Traversals: Base (1 report): <u> 1/1 </u> ; FU Alarms/Traversals: <u> </u> Base (3 report): <u> </u> ; FU Alarms/Traversals: <u> </u> Adj. (1 report): <u> </u> ; FU Alarms/Traversals: <u> </u> Adj. (3 report): <u> </u> ; FU Alarms/Traversals: <u> </u> Other observations (Short link, data problems, etc.; use lines as needed) | |

| | |
|--|--|
| NU Inc. #: <u>3</u> | NWCD Incident #: <u>None</u> |
| Date: <u>08/09/95</u> | First report: <u>15:27</u> Clear: <u>16:15</u> |
| Type: <u>Short Term Cons.</u> | Inc. Location: <u>WB Central, Central & Arlington Hts.</u> |
| Segment #: <u>8ee89-8f18c</u> Direction: <u>EB</u> Link Location: (Incident, Upstream, Downstream): <u>Cons. Side</u> Turn: _____ Inc. Detections/Traversals: Base (1 report): <u>0/1</u> ; FU Alarms/Traversals: _____ Base (3 report): _____; FU Alarms/Traversals: _____ Adj. (1 report): _____; FU Alarms/Traversals: _____ Adj. (3 report): _____; FU Alarms/Traversals: _____ Other observations (Short link, data problems, etc.; use lines as needed) | |
| Segment #: <u>8ee87-8ee82</u> Direction: <u>EB</u> Link Location: (Incident, Upstream, Downstream): _____ Turn: _____ Inc. Detections/Traversals: Base (1 report): <u>0/1</u> ; FU Alarms/Traversals: _____ Base (3 report): _____; FU Alarms/Traversals: _____ Adj. (1 report): _____; FU Alarms/Traversals: _____ Adj. (3 report): _____; FU Alarms/Traversals: _____ Other observations (Short link, data problems, etc.; use lines as needed) | |

| | |
|---|--|
| NU Inc. #: <u>4</u> | NWCD Incident #: <u>AHF9504561 (AHP9534591)</u> |
| Date: <u>08/10/95</u> | First report: <u>16:38</u> Clear: <u>16:51 (18:01)</u> |
| Type: <u>ACPI</u> | Inc. Location: <u>Oakton, btw Elizabeth & Badger</u> |
| Incident PV IDs: <u>15</u> , <u>17</u> , <u>57</u> , _____ | |
| Follow-up PV IDs: Date: <u>11/07</u> ; <u>09</u> , <u>52</u> , _____, _____ Date: <u>11/15</u> ; <u>17</u> , <u>0B</u> , <u>57</u> , _____ Date: <u>11/17</u> ; <u>11</u> , <u>4B</u> , <u>14</u> , _____ | |
| Use distinct block for each link (and turning movement) | |
| Segment #: <u>a6f2a-905f6</u> Direction: <u>WB</u> Link Location: (Incident, Upstream, Downstream): <u>INC</u> Turn: <u>Through</u> Inc. Detections/Traversals: Base (1 report): <u>1/2</u> ; FU Alarms/Traversals: <u>0/35</u> Base (3 report): _____; FU Alarms/Traversals: <u>0/33</u> Adj. (1 report): _____; FU Alarms/Traversals: _____ Adj. (3 report): _____; FU Alarms/Traversals: _____ Other observations (Short link, data problems, etc.; use lines as needed) | |
| Segment #: <u>905f6-905fe</u> Direction: <u>WB</u> Link Location: (Incident, Upstream, Downstream): <u>DN1</u> Turn: <u>Through</u> Inc. Detections/Traversals: Base (1 report): <u>2/3</u> ; FU Alarms/Traversals: <u>27/38</u> Base (3 report): <u>0/1</u> ; FU Alarms/Traversals: <u>32/36</u> Adj. (1 report): <u>0/3</u> ; FU Alarms/Traversals: <u>2/38</u> Adj. (3 report): <u>0/1</u> ; FU Alarms/Traversals: <u>0/36</u> Other observations (Short link, data problems, etc.; use lines as needed): <u>Lots of "low-speed" link_tr in FU traversals .</u> | |
| Segment #: <u>8905f6-8a6f2a</u> Direction: <u>EB</u> Link Location: (Incident, Upstream, Downstream): <u>UP1</u> Turn: <u>Through</u> Inc. Detections/Traversals: Base (1 report): <u>0/1</u> ; FU Alarms/Traversals: <u>0/42</u> Base (3 report): _____; FU Alarms/Traversals: <u>0/40</u> Adj. (1 report): <u>0/1</u> ; FU Alarms/Traversals: <u>0/42</u> Adj. (3 report): _____; FU Alarms/Traversals: <u>0/40</u> Other observations (Short link, data problems, etc.; use lines as needed) | |

| | |
|--|--|
| NU Inc. #: <u> 4 </u> | NWCD Incident #: <u> AHF9504561 (AHP9534591) </u> |
| Date: <u> 08/10/95 </u> | First report: <u> 16:38 </u> Clear: <u> 16:51 (18:01) </u> |
| Type: <u> ACPI </u> | Inc. Location: <u> Oakton, btw Elizabeth & Badger </u> |
| Segment #: <u> 8a6f2a-8905ad </u> Direction: <u> EB </u> Link Location: (Incident, Upstream, Downstream): <u> INC </u> Turn: <u> Through </u> Inc. Detections/Traversals: Base (1 report): <u> 0/2 </u> ; FU Alarms/Traversals: <u> 0/15 </u> Base (3 report): <u> </u> ; FU Alarms/Traversals: <u> 0/13 </u> Adj. (1 report): <u> 0/2 </u> ; FU Alarms/Traversals: <u> 0/15 </u> Adj. (3 report): <u> </u> ; FU Alarms/Traversals: <u> 0/13 </u> Other observations (Short link, data problems, etc.; use lines as needed) | |

| | |
|--|---|
| NU Inc. #: <u>5</u> | NWCD Incident #: <u>None</u> |
| Date: <u>08/10/95</u> First report: <u>15:10</u> Clear: <u>15:25</u> | |
| Type: <u>Stalled Freight Train</u> | Inc. Location: <u>Hintz at RR track, btw Wheeling & Glenn</u> |
| Incident PV IDs: <u>57</u> , <u>0B</u> , <u>10</u> , <u>17</u> | |
| Follow-up PV IDs: Date: <u>08/14</u> ; <u>5C</u> , <u>0D</u> , <u>14</u> , <u>50</u> , <u>17</u> , <u>1B</u> , Date: <u>08/16</u> ; <u>45</u> , <u>5C</u> , <u>3E</u> , <u>1A</u> , <u>15</u> , <u>10</u> , <u>0E</u> , <u>0B</u> , <u>11</u> , <u>0A</u> , Date: <u>08/17</u> ; <u>10</u> , <u>41</u> , <u>50</u> , _____ Date: <u>11/21</u> ; <u>2B</u> , _____, _____, _____ | |
| Use distinct block for each link (and turning movement) | |
| Segment #: <u>88d023-88d20b</u> Direction: <u>EB</u> Link Location: (Incident, Upstream, Downstream): <u>INC</u> Turn: <u>Through</u> Inc. Detections/Traversals: Base (1 report): <u>0/6</u> ; FU Alarms/Traversals: <u>0/16</u> Base (3 report): <u>0/4</u> ; FU Alarms/Traversals: <u>0/14</u> Adj. (1 report): _____ ; FU Alarms/Traversals: _____ Adj. (3 report): _____ ; FU Alarms/Traversals: _____ Other observations (Short link, data problems, etc.; use lines as needed) | |
| Segment #: <u>88d1fe-88d203</u> Direction: <u>EB</u> Link Location: (Incident, Upstream, Downstream): <u>UP1</u> Turn: <u>Through</u> Inc. Detections/Traversals: Base (1 report): <u>0/1</u> ; FU Alarms/Traversals: <u>0/14</u> Base (3 report): _____ ; FU Alarms/Traversals: <u>0/12</u> Adj. (1 report): <u>0/1</u> ; FU Alarms/Traversals: <u>0/14</u> Adj. (3 report): _____ ; FU Alarms/Traversals: <u>0/12</u> Other observations (Short link, data problems, etc.; use lines as needed) | |
| Segment #: <u>8d203-8d8f3</u> Direction: <u>WB</u> Link Location: (Incident, Upstream, Downstream): <u>INC</u> Turn: <u>Turn</u> Inc. Detections/Traversals: Base (1 report): <u>1/2</u> ; FU Alarms/Traversals: <u>0/9</u> Base (3 report): _____ ; FU Alarms/Traversals: <u>0/7</u> Adj. (1 report): <u>1/2</u> ; FU Alarms/Traversals: <u>0/9</u> Adj. (3 report): _____ ; FU Alarms/Traversals: <u>0/7</u> Other observations (Short link, data problems, etc.; use lines as needed): | |

| | |
|---|---|
| NU Inc. #: <u>5</u> | NWCD Incident #: <u>None</u> |
| Date: <u>08/10/95</u> First report: <u>15:10</u> Clear: <u>15:25</u> | |
| Type: <u>Stalled Freight Train</u> | Inc. Location: <u>Hintz at RR track, btw Wheeling & Glenn</u> |
| Segment #: <u>8d203-8d1fe</u> Direction: <u>WB</u> Link Location: (Incident, Upstream, Downstream): <u>INC</u> Turn: <u>Through</u> Inc. Detections/Traversals: Base (1 report): <u>2/6</u> ; FU Alarms/Traversals: <u>0/28</u> Base (3 report): <u>1/4</u> ; FU Alarms/Traversals: <u>0/26</u> Adj. (1 report): <u>1/6</u> ; FU Alarms/Traversals: <u>0/28</u> Adj. (3 report): <u>1/4</u> ; FU Alarms/Traversals: <u>0/26</u> Other observations (Short link, data problems, etc.; use lines as needed) | |
| Segment #: <u>8d20b-8d203</u> Direction: <u>WB</u> Link Location: (Incident, Upstream, Downstream): <u>UP1</u> Turn: <u> </u> Inc. Detections/Traversals: Base (1 report): <u>0/2</u> ; FU Alarms/Traversals: <u>0/5</u> Base (3 report): <u> </u> ; FU Alarms/Traversals: <u>0/3</u> Adj. (1 report): <u>0/2</u> ; FU Alarms/Traversals: <u>0/5</u> Adj. (3 report): <u> </u> ; FU Alarms/Traversals: <u>0/3</u> Other observations (Short link, data problems, etc.; use lines as needed) | |

| | |
|---|--|
| NU Inc. #: <u>6</u> | NWCD Incident #: <u>None</u> |
| Date: <u>08/11/95</u> | First report: <u>15:45</u> Clear: <u>16:55</u> |
| Type: <u>Repair Truck</u> | Inc. Location: <u>SB Hintz, Hintz & Arlington Hts.</u> |
| Incident PV IDs: <u>50</u> , <u>15</u> , _____, _____ | |
| Follow-up PV IDs: Date: <u>08/23</u> ; <u>0A</u> , _____, _____, _____ Date: <u>08/24</u> ; <u>57</u> , <u>2B</u> , _____, _____ Date: <u>08/25</u> ; <u>59</u> , <u>5C</u> , _____, _____ Date: <u>11/07</u> ; <u>09</u> , <u>5A</u> , _____, _____ Date: <u>11/15</u> ; <u>16</u> , _____, _____, _____ | |
| Use distinct block for each link (and turning movement) | |
| Segment #: <u>88cebf-8d2a8</u> Direction: <u>SB</u> Link Location: (Incident, Upstream, Downstream): <u>INC</u> Turn: <u>Through</u> Inc. Detections/Traversals: Base (1 report): <u>0/5</u> ; FU Alarms/Traversals: <u>0/17</u> Base (3 report): <u>0/3</u> ; FU Alarms/Traversals: <u>0/15</u> Adj. (1 report): <u>0/5</u> ; FU Alarms/Traversals: <u>0/17</u> Adj. (3 report): <u>0/3</u> ; FU Alarms/Traversals: <u>0/15</u> Other observations (Short link, data problems, etc.; use lines as needed) | |
| Segment #: <u>892387-88cbef</u> Direction: <u>SB</u> Link Location: (Incident, Upstream, Downstream): <u>UP1</u> Turn: <u>Through</u> Inc. Detections/Traversals: Base (1 report): <u>0/4</u> ; FU Alarms/Traversals: <u>0/16</u> Base (3 report): <u>0/2</u> ; FU Alarms/Traversals: <u>0/14</u> Adj. (1 report): _____; FU Alarms/Traversals: _____ Adj. (3 report): _____; FU Alarms/Traversals: _____ Other observations (Short link, data problems, etc.; use lines as needed) | |
| Segment #: <u>8cebf-92387</u> Direction: <u>NB</u> Link Location: (Incident, Upstream, Downstream): <u>INC</u> Turn: <u>Through</u> Inc. Detections/Traversals: Base (1 report): <u>0/6</u> ; FU Alarms/Traversals: <u>0/35</u> Base (3 report): <u>0/4</u> ; FU Alarms/Traversals: <u>0/33</u> Adj. (1 report): <u>0/6</u> ; FU Alarms/Traversals: <u>0/35</u> Adj. (3 report): <u>0/4</u> ; FU Alarms/Traversals: <u>0/33</u> Other observations (Short link, data problems, etc.; use lines as needed) | |

| | |
|---|--|
| NU Inc. #: <u> 6 </u> | NWCD Incident #: <u> None </u> |
| Date: <u> 08/11/95 </u> | First report: <u> 15:45 </u> Clear: <u> 16:55 </u> |
| Type: <u> Repair Truck </u> | Inc. Location: <u> SB Hintz, Hintz & Arlington Hts. </u> |
| Segment #: <u> 88d2a8-8cebf </u> Direction: <u> NB </u> Link Location: (Incident, Upstream, Downstream): <u> UP1 </u> Turn: <u> Through </u> Inc. Detections/Traversals: Base (1 report): <u> 0/7 </u> ; FU Alarms/Traversals: <u> 5/35 </u> Base (3 report): <u> 0/5 </u> ; FU Alarms/Traversals: <u> 3/33 </u> Adj. (1 report): <u> 0/7 </u> ; FU Alarms/Traversals: <u> 0/35 </u> Adj. (3 report): <u> 0/5 </u> ; FU Alarms/Traversals: <u> 0/33 </u> Other observations (Short link, data problems, etc.; use lines as needed) | |

| | |
|---|---|
| NU Inc. #: <u>7</u> | NWCD Incident #: <u>DAP9534050</u> |
| Date: <u>08/11/95</u> | First report: <u>17:53</u> Clear: <u>18:32</u> |
| Type: <u>ACPD</u> | Inc. Location: <u>EB Lake Cook, Lake & Corporate Dr.</u> |
| Incident PV IDs: <u>41</u> , <u>50</u> , _____, _____ | |
| Follow-up PV IDs: | |
| Date: <u>08/15</u> ; | <u>0B</u> , <u>2B</u> , <u>10</u> , <u>11</u> , <u>19</u> , <u>5C</u> |
| Date: <u>08/18</u> ; | <u>1A</u> , <u>0B</u> , <u>28</u> , <u>09</u> |
| Date: <u>08/29</u> ; | <u>1B</u> , <u>5C</u> , <u>10</u> , <u>14</u> , <u>57</u> |
| Date: <u>11/09</u> ; | <u>2B</u> , <u>52</u> , _____, _____ |
| Date: <u>11/14</u> ; | <u>0B</u> , <u>16</u> , <u>2B</u> , <u>69</u> |
| Date: <u>11/16</u> ; | <u>2B</u> , _____, _____, _____ |
| Use distinct block for each link (and turning movement) | |
| Segment #: <u>89c51a-88c4a2</u> Direction: <u>EB</u> | |
| Link Location: (Incident, Upstream, Downstream): <u>INC</u> Turn: <u>Turn</u> | |
| Inc. Detections/Traversals: | |
| Base (1 report): <u>0/1</u> ; FU Alarms/Traversals: <u>N/A</u> | |
| Base (3 report): _____; FU Alarms/Traversals: _____ | |
| Adj. (1 report): _____; FU Alarms/Traversals: _____ | |
| Adj. (3 report): _____; FU Alarms/Traversals: _____ | |
| Other observations (Short link, data problems, etc.; use lines as needed): <u>No FU traversals.</u> | |
| Segment #: <u>89c51a-88c4a4</u> Direction: <u>EB</u> | |
| Link Location: (Incident, Upstream, Downstream): <u>INC</u> Turn: <u>Through</u> | |
| Inc. Detections/Traversals: | |
| Base (1 report): <u>0/1</u> ; FU Alarms/Traversals: <u>0/1</u> | |
| Base (3 report): _____; FU Alarms/Traversals: _____ | |
| Adj. (1 report): _____; FU Alarms/Traversals: _____ | |
| Adj. (3 report): _____; FU Alarms/Traversals: _____ | |
| Other observations (Short link, data problems, etc.; use lines as needed) | |
| Segment #: <u>89c5dc-89c51a</u> Direction: <u>EB</u> | |
| Link Location: (Incident, Upstream, Downstream): <u>UPI</u> Turn: <u>Through</u> | |
| Inc. Detections/Traversals: | |
| Base (1 report): <u>0/2</u> ; FU Alarms/Traversals: <u>0/41</u> | |
| Base (3 report): _____; FU Alarms/Traversals: <u>0/39</u> | |
| Adj. (1 report): <u>0/2</u> ; FU Alarms/Traversals: <u>0/41</u> | |
| Adj. (3 report): _____; FU Alarms/Traversals: <u>0/39</u> | |
| Other observations (Short link, data problems, etc.; use lines as needed) | |

| | |
|--|--|
| NU Inc. #: <u>7</u> | NWCD Incident #: <u>DAP9534050</u> |
| Date: <u>08/11/95</u> | First report: <u>17:53</u> Clear: <u>18:32</u> |
| Type: <u>ACPD</u> | Inc. Location: <u>EB Lake Cook, Lake & Corporate Dr.</u> |
| Segment #: <u>9c51a-9c5dc</u> Direction: <u>WB</u> Link Location: (Incident, Upstream, Downstream): <u>INC</u> Turn: <u>Through</u> Inc. Detections/Traversals: Base (1 report): <u>0/4</u> ; FU Alarms/Traversals: <u>0/23</u> Base (3 report): <u>0/2</u> ; FU Alarms/Traversals: <u>0/21</u> Adj. (1 report): _____; FU Alarms/Traversals: _____ Adj. (3 report): _____; FU Alarms/Traversals: _____ Other observations (Short link, data problems, etc.; use lines as needed): | |
| Segment #: <u>8c4a2-9c51a</u> Direction: <u>SB/WB</u> Link Location: (Incident, Upstream, Downstream): <u>UP1</u> Turn: <u>Turn</u> Inc. Detections/Traversals: Base (1 report): <u>0/1</u> ; FU Alarms/Traversals: <u>N/A</u> Base (3 report): _____; FU Alarms/Traversals: _____ Adj. (1 report): _____; FU Alarms/Traversals: _____ Adj. (3 report): _____; FU Alarms/Traversals: _____ Other observations (Short link, data problems, etc.; use lines as needed): | |
| Segment #: <u>8c4a4-9c51a</u> Direction: <u>WB</u> Link Location: (Incident, Upstream, Downstream): <u>UP1</u> Turn: <u>Through</u> Inc. Detections/Traversals: Base (1 report): <u>0/1</u> ; FU Alarms/Traversals: <u>N/A</u> Base (3 report): _____; FU Alarms/Traversals: _____ Adj. (1 report): _____; FU Alarms/Traversals: _____ Adj. (3 report): _____; FU Alarms/Traversals: _____ Other observations (Short link, data problems, etc.; use lines as needed): <u>No FU traversals</u> . | |

| | |
|---|--|
| NU Inc. #: <u>8</u> | NWCD Incident #: <u>MPP9542752 (MPF9503737)</u> |
| Date: <u>08/21/95</u> First report: <u>16:52</u> Clear: <u>17:43</u> | |
| Type: <u>ACPI</u> | Inc. Location: <u>NWB Algonquin, Algonquin & Busse</u> |
| Incident PV IDs: <u>17</u> , <u>57</u> , <u>0A</u> | |
| Follow-up PV IDs: Date: <u>08/22</u> ; <u>0A</u> , <u>0B</u> , _____, _____ Date: <u>08/23</u> ; <u>15</u> , <u>41</u> , <u>57</u> , _____ Date: <u>08/24</u> ; <u>14</u> , <u>41</u> , _____, _____ | |
| Use distinct block for each link (and turning movement) | |
| Segment #: <u>88ff7a-8ff7b</u> Direction: <u>SB/EB</u> Link Location: (Incident, Upstream, Downstream): <u>UP1</u> Turn: <u>Turn</u> Inc. Detections/Traversals: Base (1 report): <u>0/1</u> ; FU Alarms/Traversals: <u>N/A</u> Base (3 report): _____; FU Alarms/Traversals: _____ Adj. (1 report): _____; FU Alarms/Traversals: _____ Adj. (3 report): _____; FU Alarms/Traversals: _____ Other observations (Short link, data problems, etc.; use lines as needed): <u>No FU traversals</u> . | |
| Segment #: <u>88ff7b-89e6da</u> Direction: <u>EB</u> Link Location: (Incident, Upstream, Downstream): <u>UP1</u> Turn: <u>Turn</u> Inc. Detections/Traversals: Base (1 report): <u>1/1</u> ; FU Alarms/Traversals: <u>N/A</u> Base (3 report): _____; FU Alarms/Traversals: _____ Adj. (1 report): _____; FU Alarms/Traversals: _____ Adj. (3 report): _____; FU Alarms/Traversals: _____ Other observations (Short link, data problems, etc.; use lines as needed): <u>Short link combined; one erratic CTT in Inc. traversals (561 mph)</u> | |
| Segment #: <u>88ff7b-89e6d5</u> Direction: <u>EB</u> Link Location: (Incident, Upstream, Downstream): <u>UP1</u> Turn: <u>Through</u> Inc. Detections/Traversals: Base (1 report): <u>0/2</u> ; FU Alarms/Traversals: <u>2/6</u> Base (3 report): _____; FU Alarms/Traversals: <u>0/4</u> Adj. (1 report): <u>0/2</u> ; FU Alarms/Traversals: <u>0/6</u> Adj. (3 report): _____; FU Alarms/Traversals: <u>0/4</u> Other observations (Short link, data problems, etc.; use lines as needed): <u>Short link combined; one erratic CTT (92 mph) in Inc. & one erratic CTTs (162 mph) in FU traversals.</u> | |

| | |
|--|--|
| NU Inc. #: <u>8</u> | NWCD Incident #: <u>MPP9542752 (MPF9503737)</u> |
| Date: <u>08/21/95</u> | First report: <u>16:52</u> Clear: <u>17:43</u> |
| Type: <u>ACPI</u> | Inc. Location: <u>NWB Algonquin, Algonquin & Busse</u> |
| <p>Segment #: <u>9e6d5-8ff7a</u> Direction: <u>WB</u> Link Location: (Incident, Upstream, Downstream): <u>UP1</u> Turn: <u>Turn</u> Inc. Detections/Traversals: Base (1 report): <u>1/2</u>; FU Alarms/Traversals: <u>N/A</u> Base (3 report): _____; FU Alarms/Traversals: _____ Adj. (1 report): <u>1/2</u>; FU Alarms/Traversals: _____ Adj. (3 report): _____; FU Alarms/Traversals: _____ Other observations (Short link, data problems, etc.; use lines as needed): <u>Short link combined; one erratic CTT (70 mph) in Inc. traversals.</u></p> | |
| <p>Segment #: <u>9e6d5-8ff2b</u> Direction: <u>WB</u> Link Location: (Incident, Upstream, Downstream): <u>UP1</u> Turn: <u>Through</u> Inc. Detections/Traversals: Base (1 report): <u>1/1</u>; FU Alarms/Traversals: <u>4/6</u> Base (3 report): _____; FU Alarms/Traversals: <u>1/4</u> Adj. (1 report): <u>0/1</u>; FU Alarms/Traversals: <u>0/6</u> Adj. (3 report): _____; FU Alarms/Traversals: <u>0/4</u> Other observations (Short link, data problems, etc.; use lines as needed): <u>Short link combined; one erratic CTT (668.86 mph) in Inc. & 4 erratic CTTs in FU traversals.</u></p> | |

| | |
|--|--|
| NU Inc. #: <u>9</u> | NWCD Incident #: <u>EGP9537699</u> |
| Date: <u>08/23/95</u> | First report: <u>14:57</u> Clear: <u>15:58</u> |
| Type: <u>ACPD</u> | Inc. Location: <u>WB Landmeier, Landmeier & Lively</u> |
| Incident PV IDs: <u>2B</u> , <u>14</u> , _____, _____ | |
| Follow-up PV IDs: Date: <u>08/25</u> ; <u>50</u> , <u>15</u> , <u>0D</u> , _____ Date: _____; _____, _____, _____, _____ Date: _____; _____, _____, _____, _____ Date: _____; _____, _____, _____, _____ | |
| Use distinct block for each link (and turning movement) | |
| Segment #: <u>90abe-890b13</u> Direction: <u>SB/EB</u> Link Location: (Incident, Upstream, Downstream): <u>UPI</u> Turn: <u>Turn</u> Inc. Detections/Traversals: Base (1 report): <u>0/1</u> ; FU Alarms/Traversals: <u>N/A</u> Base (3 report): _____; FU Alarms/Traversals: _____ Adj. (1 report): _____; FU Alarms/Traversals: _____ Adj. (3 report): _____; FU Alarms/Traversals: _____ Other observations (Short link, data problems, etc.; use lines as needed): <u>No FU traversals.</u> | |
| Segment #: <u>890992-890b13</u> Direction: <u>EB</u> Link Location: (Incident, Upstream, Downstream): <u>UPI</u> Turn: <u>Through</u> Inc. Detections/Traversals: Base (1 report): <u>0/1</u> ; FU Alarms/Traversals: <u>0/3</u> Base (3 report): _____; FU Alarms/Traversals: <u>0/1</u> Adj. (1 report): <u>0/1</u> ; FU Alarms/Traversals: <u>0/3</u> Adj. (3 report): _____; FU Alarms/Traversals: <u>0/1</u> Other observations (Short link, data problems, etc.; use lines as needed) | |
| Segment #: <u>890b13-890ccc</u> Direction: <u>EB</u> Link Location: (Incident, Upstream, Downstream): <u>INC</u> Turn: <u>Through</u> Inc. Detections/Traversals: Base (1 report): <u>0/1</u> ; FU Alarms/Traversals: <u>0/2</u> Base (3 report): _____; FU Alarms/Traversals: _____ Adj. (1 report): <u>0/1</u> ; FU Alarms/Traversals: <u>0/2</u> Adj. (3 report): _____; FU Alarms/Traversals: _____ Other observations (Short link, data problems, etc.; use lines as needed) | |

| | |
|---|--|
| NU Inc. #: <u>9</u> | NWCD Incident #: <u>EGP9537699</u> |
| Date: <u>08/23/95</u> | First report: <u>14:57</u> Clear: <u>15:58</u> |
| Type: <u>ACPD</u> | Inc. Location: <u>WB Landmeier, Landmeier & Lively</u> |
| Segment #: <u>89e727-90b13</u> Direction: <u>SB/WB</u> Link Location: (Incident, Upstream, Downstream): <u>UP1</u> Turn: <u>Turn</u> Inc. Detections/Traversals: Base (1 report): <u>0/1</u> ; FU Alarms/Traversals: <u>N/A</u> Base (3 report): _____; FU Alarms/Traversals: _____ Adj. (1 report): _____; FU Alarms/Traversals: _____ Adj. (3 report): _____; FU Alarms/Traversals: _____ Other observations (Short link, data problems, etc.; use lines as needed): <u>No FU traversals.</u> | |
| Segment #: <u>90b13-90992</u> Direction: <u>WB</u> Link Location: (Incident, Upstream, Downstream): <u>INC</u> Turn: <u>Through</u> Inc. Detections/Traversals: Base (1 report): <u>0/2</u> ; FU Alarms/Traversals: <u>0/3</u> Base (3 report): _____; FU Alarms/Traversals: <u>0/1</u> Adj. (1 report): <u>0/2</u> ; FU Alarms/Traversals: <u>0/3</u> Adj. (3 report): _____; FU Alarms/Traversals: <u>0/1</u> Other observations (Short link, data problems, etc.; use lines as needed) | |
| Segment #: <u>90b13-890abe</u> Direction: <u>WB</u> Link Location: (Incident, Upstream, Downstream): <u>INC</u> Turn: <u>Turn</u> Inc. Detections/Traversals: Base (1 report): <u>1/1</u> ; FU Alarms/Traversals: <u>0/1</u> Base (3 report): _____; FU Alarms/Traversals: _____ Adj. (1 report): _____; FU Alarms/Traversals: _____ Adj. (3 report): _____; FU Alarms/Traversals: _____ Other observations (Short link, data problems, etc.; use lines as needed): <u>Because of time gaps, not many Inc. traversals were found in this case.</u> | |

| | |
|--|--|
| NU Inc. #: <u>10</u> | NWCD Incident #: <u>EGP9537888</u> |
| Date: <u>08/24/95</u> First report: <u>14:57 (15:19 field report)</u> Clear: <u>15:02 (16:25 field report)</u> | |
| Type: <u>LMAL</u> | Inc. Location: <u>Busse, Busse & Devon</u> |
| Incident PV IDs: <u>15</u> , <u>OA</u> , _____, _____ | |
| Follow-up PV IDs: Date: <u>08/25</u> ; <u>19</u> , <u>0A</u> , _____, _____ Date: _____; _____, _____, _____, _____ Date: _____; _____, _____, _____, _____ Date: _____; _____, _____, _____, _____ | |
| Use distinct block for each link (and turning movement) | |
| Segment #: <u>8a60c6-a6381</u> Direction: <u>SB</u> Link Location: (Incident, Upstream, Downstream): <u>INC</u> Turn: <u>Through</u> Inc. Detections/Traversals: Base (1 report): <u>3/5</u> ; FU Alarms/Traversals: <u>0/7</u> Base (3 report): <u>3/3</u> ; FU Alarms/Traversals: <u>0/5</u> Adj. (1 report): <u>1/5</u> ; FU Alarms/Traversals: <u>0/7</u> Adj. (3 report): <u>3/3</u> ; FU Alarms/Traversals: <u>0/5</u> Other observations (Short link, data problems, etc.; use lines as needed) | |
| Segment #: <u>8a5dff-8a60c6</u> Direction: <u>SB</u> Link Location: (Incident, Upstream, Downstream): <u>UP1</u> Turn: <u>Through</u> Inc. Detections/Traversals: Base (1 report): <u>0/5</u> ; FU Alarms/Traversals: <u>0/7</u> Base (3 report): <u>0/3</u> ; FU Alarms/Traversals: <u>0/5</u> Adj. (1 report): <u>2/5</u> ; FU Alarms/Traversals: <u>0/7</u> Adj. (3 report): <u>2/3</u> ; FU Alarms/Traversals: <u>0/5</u> Other observations (Short link, data problems, etc.; use lines as needed) | |
| Segment #: <u>a6381-926c5f</u> Direction: <u>SB</u> Link Location: (Incident, Upstream, Downstream): <u>DN1</u> Turn: <u>Turn</u> Inc. Detections/Traversals: Base (1 report): <u>1/2</u> ; FU Alarms/Traversals: <u>N/A</u> Base (3 report): _____; FU Alarms/Traversals: _____ Adj. (1 report): _____; FU Alarms/Traversals: _____ Adj. (3 report): _____; FU Alarms/Traversals: _____ Other observations (Short link, data problems, etc.; use lines as needed): <u>No FU traversals.</u> | |

| | |
|---|--|
| NU Inc. #: <u>10</u> | NWCD Incident #: <u>EGP9537888</u> |
| Date: <u>08/24/95</u> First report: <u>14:57 (15:19 field report)</u> Clear: <u>15:02 (16:25 field report)</u> | |
| Type: <u>LMAL</u> | Inc. Location: <u>Busse, Busse & Devon</u> |
| Segment #: <u>a6381-129516</u> Direction: <u>SB</u> Link Location: (Incident, Upstream, Downstream): <u>DN1</u> Turn: <u>Through</u> Inc. Detections/Traversals: Base (1 report): <u>3/3</u> ; FU Alarms/Traversals: <u>3/7</u> Base (3 report): <u>1/1</u> ; FU Alarms/Traversals: <u>4/5</u> Adj. (1 report): <u>0/3</u> ; FU Alarms/Traversals: <u>0/7</u> Adj. (3 report): <u>0/1</u> ; FU Alarms/Traversals: <u>0/5</u> Other observations (Short link, data problems, etc.; use lines as needed) | |
| Segment #: <u>a60c6-a5dff</u> Direction: <u>NB</u> Link Location: (Incident, Upstream, Downstream): <u>INC</u> Turn: <u>Through</u> Inc. Detections/Traversals: Base (1 report): <u>0/5</u> ; FU Alarms/Traversals: <u>0/7</u> Base (3 report): <u>0/3</u> ; FU Alarms/Traversals: <u>0/5</u> Adj. (1 report): <u>1/5</u> ; FU Alarms/Traversals: <u>0/7</u> Adj. (3 report): <u>0/3</u> ; FU Alarms/Traversals: <u>0/5</u> Other observations (Short link, data problems, etc.; use lines as needed) | |

| | |
|---|--|
| NU Inc. #: <u> 11 </u> | NWCD Incident #: <u> EGF950502 </u> |
| Date: <u> 08/22/95 </u> First report: <u> 16:07 </u> Clear: <u> 16:46 </u> | |
| Type: <u> ACPI </u> | Inc. Location: <u> Busse, Oakton & Howard </u> |
| Incident PV IDs: <u> 41 </u> , <u> 09 </u> , _____, _____ | |
| Follow-up PV IDs: Date: _____; _____, _____, _____, _____ Date: _____; _____, _____, _____, _____ Date: _____; _____, _____, _____, _____ Date: _____; _____, _____, _____, _____ | |
| Use distinct block for each link (and turning movement) | |
| Segment #: _____ Direction: _____ Link Location: (Incident, Upstream, Downstream): _____ Turn: _____ Inc. Detections/Traversals: Base (1 report): _____; FU Alarms/Traversals: _____ Base (3 report): _____; FU Alarms/Traversals: _____ Adj. (1 report): _____; FU Alarms/Traversals: _____ Adj. (3 report): _____; FU Alarms/Traversals: _____ Other observations (Short link, data problems, etc.; use lines as needed) | |
| Segment #: _____ Direction: _____ Link Location: (Incident, Upstream, Downstream): _____ Turn: _____ Inc. Detections/Traversals: Base (1 report): _____; FU Alarms/Traversals: _____ Base (3 report): _____; FU Alarms/Traversals: _____ Adj. (1 report): _____; FU Alarms/Traversals: _____ Adj. (3 report): _____; FU Alarms/Traversals: _____ Other observations (Short link, data problems, etc.; use lines as needed) | |

| | |
|---|---|
| NU Inc. #: <u>12</u> | NWCD Incident #: <u>AHP9550091</u> |
| Date: <u>11/20/95</u> | First report: <u>13:40</u> Clear: <u>14:09</u> |
| Type: <u>LMAL</u> | Inc. Location: <u>WB Algonquin, Algonquin & Wilke</u> |
| Incident PV IDs: <u>1B</u> , <u>11</u> , _____, _____ | |
| Follow-up PV IDs: | |
| Date: <u>11/07</u> ; | <u>52</u> , <u>0B</u> , <u>09</u> , _____ |
| Date: <u>11/08</u> ; | <u>0B</u> , <u>0A</u> , <u>19</u> , _____ |
| Date: <u>11/09</u> ; | <u>5A</u> , <u>1B</u> , <u>11</u> , <u>19</u> |
| Date: <u>11/13</u> ; | <u>2B</u> , <u>5A</u> , _____, _____ |
| Date: <u>11/14</u> ; | <u>32</u> , <u>19</u> , <u>2B</u> , _____ |
| Date: <u>11/15</u> ; | <u>0B</u> , <u>5A</u> , _____, _____ |
| Date: <u>11/17</u> ; | <u>4B</u> , <u>5A</u> , _____, _____ |
| Date: <u>11/21</u> ; | <u>14</u> , <u>19</u> , <u>44</u> , <u>11</u> |
| Use distinct block for each link (and turning movement) | |
| Segment #: <u>88f127-88f443</u> Direction: <u>EB</u> | |
| Link Location: (Incident, Upstream, Downstream): <u>INC</u> Turn: <u>Through</u> | |
| Inc. Detections/Traversals: | |
| Base (1 report): <u>0/3</u> ; FU Alarms/Traversals: <u>0/32</u> | |
| Base (3 report): <u>0/1</u> ; FU Alarms/Traversals: <u>0/30</u> | |
| Adj. (1 report): <u>1/3</u> ; FU Alarms/Traversals: <u>0/32</u> | |
| Adj. (3 report): <u>1/1</u> ; FU Alarms/Traversals: <u>0/30</u> | |
| Other observations (Short link, data problems, etc.; use lines as needed): <u>Several erratic link_tr in FU traversals.</u> | |
| Segment #: <u>88f443-89e87c</u> Direction: <u>SEB</u> | |
| Link Location: (Incident, Upstream, Downstream): <u>DN</u> Turn: <u>Through</u> | |
| Inc. Detections/Traversals: | |
| Base (1 report): <u>1/2</u> ; FU Alarms/Traversals: <u>10/42</u> | |
| Base (3 report): _____ ; FU Alarms/Traversals: <u>7/40</u> | |
| Adj. (1 report): <u>0/2</u> ; FU Alarms/Traversals: <u>0/42</u> | |
| Adj. (3 report): _____ ; FU Alarms/Traversals: <u>0/40</u> | |
| Other observations (Short link, data problems, etc.; use lines as needed): <u>Short link combined; lots of erratic CTTs in FU traversals.</u> | |

| | |
|--|---|
| NU Inc. #: <u>12</u> | NWCD Incident #: <u>AHP9550091</u> |
| Date: <u>11/20/95</u> First report: <u>13:40</u> Clear: <u>14:09</u> | |
| Type: <u>LMAL</u> | Inc. Location: <u>WB Algonquin, Algonquin & Wilke</u> |
| Segment #: <u>8f443-8f127</u> Direction: <u>WB</u> Link Location: (Incident, Upstream, Downstream): <u>INC</u> Turn: <u>Through</u> Inc. Detections/Traversals: Base (1 report): <u>2/3</u> ; FU Alarms/Traversals: <u>0/46</u> Base (3 report): <u>1/1</u> ; FU Alarms/Traversals: <u>0/44</u> Adj. (1 report): <u>2/3</u> ; FU Alarms/Traversals: <u>0/46</u> Adj. (3 report): <u>1/1</u> ; FU Alarms/Traversals: <u>0/44</u> Other observations (Short link, data problems, etc.; use lines as needed) | |

| | |
|--|--|
| NU Inc. #: <u>13</u> | NWCD Incident #: <u>MPF9505039 (MPF9557289)</u> |
| Date: <u>11/08/95</u> | First report: <u>17:01</u> Clear: <u>18:20</u> |
| Type: <u>ACPI</u> | Inc. Location: <u>WB Euclid, Euclid & Rand</u> |
| Incident PV IDs: <u>57</u> , _____, _____, _____ | |
| Follow-up PV IDs: Date: <u>08/15</u> ; <u>28</u> , <u>0D</u> , <u>41</u> , _____ Date: <u>08/17</u> ; <u>17</u> , _____ , _____ , _____ Date: <u>08/21</u> ; <u>15</u> , <u>2B</u> , <u>41</u> , _____ Date: <u>08/28</u> ; <u>59</u> , <u>0A</u> , <u>45</u> , <u>42</u> Date: <u>11/07</u> ; <u>14</u> , <u>19</u> , _____ , _____ Date: <u>11/21</u> ; <u>54</u> , _____ , _____ , _____ | |
| Use distinct block for each link (and turning movement) | |
| Segment #: <u>9e80c-89e809</u> Direction: <u>WB</u> Link Location: (Incident, Upstream, Downstream): <u>INC</u> Turn: <u>Turn</u> Inc. Detections/Traversals: Base (1 report): <u>2/2</u> ; FU Alarms/Traversals: <u>0/2</u> Base (3 report): _____ ; FU Alarms/Traversals: _____ Adj. (1 report): <u>2/2</u> ; FU Alarms/Traversals: <u>0/2</u> Adj. (3 report): _____ ; FU Alarms/Traversals: _____ Other observations (Short link, data problems, etc.; use lines as needed): <u>Short link combined.</u> | |
| Segment #: <u>9e80c-9e74b</u> Direction: <u>WB</u> Link Location: (Incident, Upstream, Downstream): <u>INC</u> Turn: <u>Through</u> Inc. Detections/Traversals: Base (1 report): <u>1/2</u> ; FU Alarms/Traversals: <u>0/20</u> Base (3 report): _____ ; FU Alarms/Traversals: <u>0/18</u> Adj. (1 report): <u>2/2</u> ; FU Alarms/Traversals: <u>0/20</u> Adj. (3 report): _____ ; FU Alarms/Traversals: <u>0/18</u> Other observations (Short link, data problems, etc.; use lines as needed): <u>Short link combined; one erratic CTT(70 mph) in Inc. traversals.</u> | |
| Segment #: <u>8e42f-9e80c</u> Direction: <u>WB</u> Link Location: (Incident, Upstream, Downstream): <u>INC</u> Turn: <u>Through</u> Inc. Detections/Traversals: Base (1 report): <u>1/2</u> ; FU Alarms/Traversals: <u>14/39</u> Base (3 report): _____ ; FU Alarms/Traversals: <u>15/37</u> Adj. (1 report): <u>0/2</u> ; FU Alarms/Traversals: <u>0/39</u> Adj. (3 report): _____ ; FU Alarms/Traversals: <u>0/37</u> Other observations (Short link, data problems, etc.; use lines as needed): <u>Short link combined; few erratic CTTs in both Inc. & FU traversals.</u> | |

| | |
|---|--|
| NU Inc. #: <u>13</u> | NWCD Incident #: <u>MPF9505039 (MPF9557289)</u> |
| Date: <u>11/08/95</u> | First report: <u>17:01</u> Clear: <u>18:20</u> |
| Type: <u>ACPI</u> | Inc. Location: <u>WB Euclid, Euclid & Rand</u> |
| Segment #: <u>89e74b-926880</u> Direction: <u>EB</u> Link Location: (Incident, Upstream, Downstream): <u>INC</u> Turn: <u>Through</u> Inc. Detections/Traversals: Base (1 report): <u>0/2</u> ; FU Alarms/Traversals: <u>0/25</u> Base (3 report): _____; FU Alarms/Traversals: <u>0/23</u> Adj. (1 report): <u>0/2</u> ; FU Alarms/Traversals: <u>0/25</u> Adj. (3 report): _____; FU Alarms/Traversals: <u>0/23</u> Other observations (Short link, data problems, etc.; use lines as needed): <u>Short link combined.</u> | |

| | |
|--|--|
| NU Inc. #: <u>14</u> | NWCD Incident #: <u>MPP9557435 (MPF9505048)</u> |
| Date: <u>11/09/95</u> | First report: <u>14:53</u> Clear: <u>16:11</u> |
| Type: <u>ACPI</u> | Inc. Location: <u>SB Main, Main & NW Hwy</u> |
| Incident PV IDs: <u>2B</u> , <u>57</u> , <u>16</u> , _____ | |
| Follow-up PV IDs: | |
| Date: <u>08/17</u> ; | <u>5C</u> , <u>50</u> , <u>59</u> , _____ |
| Date: <u>11/07</u> ; | <u>14</u> , _____, _____, _____ |
| Date: <u>11/08</u> ; | <u>16</u> , _____, _____, _____ |
| Date: <u>11/14</u> ; | <u>5A</u> , <u>57</u> , _____, _____ |
| Date: <u>11/15</u> ; | <u>16</u> , <u>19</u> , <u>14</u> , <u>52</u> |
| Use distinct block for each link (and turning movement) | |
| Segment #: <u>88ec8f-8efd8</u> Direction: <u>SB</u> | |
| Link Location: (Incident, Upstream, Downstream): <u>UP2</u> Turn: <u>Through</u> | |
| Inc. Detections/Traversals: | |
| Base (1 report): <u>0/1</u> ; | FU Alarms/Traversals: <u>0/36</u> |
| Base (3 report): _____ ; | FU Alarms/Traversals: <u>0/34</u> |
| Adj. (1 report): <u>0/1</u> ; | FU Alarms/Traversals: <u>0/36</u> |
| Adj. (3 report): _____ ; | FU Alarms/Traversals: <u>0/34</u> |
| Other observations (Short link, data problems, etc.; use lines as needed): <u>The traversal on Main.</u> | |
| Segment #: <u>88ec8f-8eebc</u> Direction: <u>SB</u> | |
| Link Location: (Incident, Upstream, Downstream): <u>UP2</u> Turn: <u>Turn</u> | |
| Inc. Detections/Traversals: | |
| Base (1 report): <u>0/4</u> ; | FU Alarms/Traversals: <u>0/36</u> |
| Base (3 report): <u>0/2</u> ; | FU Alarms/Traversals: <u>0/34</u> |
| Adj. (1 report): <u>0/4</u> ; | FU Alarms/Traversals: <u>0/36</u> |
| Adj. (3 report): <u>0/2</u> ; | FU Alarms/Traversals: <u>0/34</u> |
| Other observations (Short link, data problems, etc.; use lines as needed): <u>The traversal on Main.</u> | |
| Segment #: <u>8f00c-8ef30</u> Direction: <u>WB</u> | |
| Link Location: (Incident, Upstream, Downstream): <u>UP1</u> Turn: <u>Through</u> | |
| Inc. Detections/Traversals: | |
| Base (1 report): <u>1/5</u> ; | FU Alarms/Traversals: <u>0/3</u> |
| Base (3 report): <u>0/3</u> ; | FU Alarms/Traversals: <u>0/1</u> |
| Adj. (1 report): <u>0/5</u> ; | FU Alarms/Traversals: <u>0/3</u> |
| Adj. (3 report): <u>0/3</u> ; | FU Alarms/Traversals: <u>0/1</u> |
| Other observations (Short link, data problems, etc.; use lines as needed): <u>The traversal on NW Hwy.</u> | |

| | |
|---|--|
| NU Inc. #: <u>14</u> | NWCD Incident #: <u>MPP9557435 (MPF9505048)</u> |
| Date: <u>11/09/95</u> | First report: <u>14:53</u> Clear: <u>16:11</u> |
| Type: <u>ACPI</u> | Inc. Location: <u>SB Main, Main & NW Hwy</u> |
| Segment #: <u>8f056-8f00c</u> Direction: <u>WB</u> Link Location: (Incident, Upstream, Downstream): <u>UP2</u> Turn: <u>Through</u> Inc. Detections/Traversals: Base (1 report): <u>2/6</u> ; FU Alarms/Traversals: <u>3/30</u> Base (3 report): <u>2/4</u> ; FU Alarms/Traversals: <u>6/28</u> Adj. (1 report): <u>0/6</u> ; FU Alarms/Traversals: <u>0/30</u> Adj. (3 report): <u>0/4</u> ; FU Alarms/Traversals: <u>0/28</u> Other observations (Short link, data problems, etc.; use lines as needed): <u>The traversal on NW Hwy.</u> | |
| Segment #: <u>88ef30-88f00c</u> Direction: <u>EB</u> Link Location: (Incident, Upstream, Downstream): _____ Turn: <u>Through</u> Inc. Detections/Traversals: Base (1 report): <u>1/5</u> ; FU Alarms/Traversals: <u>0/15</u> Base (3 report): <u>0/3</u> ; FU Alarms/Traversals: <u>0/13</u> Adj. (1 report): _____ ; FU Alarms/Traversals: _____ Adj. (3 report): _____ ; FU Alarms/Traversals: _____ Other observations (Short link, data problems, etc.; use lines as needed): <u>The traversal on NW Hwy.</u> | |

| | |
|---|---|
| NU Inc. #: <u>15</u> | NWCD Incident #: <u>None</u> |
| Date: <u>11/13/95</u> First report: <u>15:00</u> Clear: <u>16:00</u> | |
| Type: <u>Short Term Const.</u> | Inc. Location: <u>NWB Higgins, btw King & ?</u> |
| Incident PV IDs: <u>2B</u> , _____, _____, _____ | |
| Follow-up PV IDs: Date: _____; _____, _____, _____, _____ Date: _____; _____, _____, _____, _____ Date: _____; _____, _____, _____, _____ Date: _____; _____, _____, _____, _____ | |
| Use distinct block for each link (and turning movement) | |
| Segment #: _____ Direction: _____ Link Location: (Incident, Upstream, Downstream): _____ Turn: _____ Inc. Detections/Traversals: Base (1 report): _____; FU Alarms/Traversals: _____ Base (3 report): _____; FU Alarms/Traversals: _____ Adj. (1 report): _____; FU Alarms/Traversals: _____ Adj. (3 report): _____; FU Alarms/Traversals: _____ Other observations (Short link, data problems, etc.; use lines as needed) | |
| Segment #: _____ Direction: _____ Link Location: (Incident, Upstream, Downstream): _____ Turn: _____ Inc. Detections/Traversals: Base (1 report): _____; FU Alarms/Traversals: _____ Base (3 report): _____; FU Alarms/Traversals: _____ Adj. (1 report): _____; FU Alarms/Traversals: _____ Adj. (3 report): _____; FU Alarms/Traversals: _____ Other observations (Short link, data problems, etc.; use lines as needed) | |
| Segment #: _____ Direction: _____ Link Location: (Incident, Upstream, Downstream): _____ Turn: _____ Inc. Detections/Traversals: Base (1 report): _____; FU Alarms/Traversals: _____ Base (3 report): _____; FU Alarms/Traversals: _____ Adj. (1 report): _____; FU Alarms/Traversals: _____ Adj. (3 report): _____; FU Alarms/Traversals: _____ Other observations (Short link, data problems, etc.; use lines as needed) | |

| | |
|---|---|
| NU Inc. #: <u>15</u> | NWCD Incident #: <u>None</u> |
| Date: <u>11/13/95</u> | First report: <u>15:00</u> Clear: <u>16:00</u> |
| Type: <u>Short Term Const.</u> | Inc. Location: <u>NWB Higgins, btw King & ?</u> |
| Segment #: _____ Direction: _____ Link Location: (Incident, Upstream, Downstream): _____ Turn: _____ Inc. Detections/Traversals: Base (1 report): _____; FU Alarms/Traversals: _____ Base (3 report): _____; FU Alarms/Traversals: _____ Adj. (1 report): _____; FU Alarms/Traversals: _____ Adj. (3 report): _____; FU Alarms/Traversals: _____ Other observations (Short link, data problems, etc.; use lines as needed) | |
| Segment #: _____ Direction: _____ Link Location: (Incident, Upstream, Downstream): _____ Turn: _____ Inc. Detections/Traversals: Base (1 report): _____; FU Alarms/Traversals: _____ Base (3 report): _____; FU Alarms/Traversals: _____ Adj. (1 report): _____; FU Alarms/Traversals: _____ Adj. (3 report): _____; FU Alarms/Traversals: _____ Other observations (Short link, data problems, etc.; use lines as needed) | |
| Segment #: _____ Direction: _____ Link Location: (Incident, Upstream, Downstream): _____ Turn: _____ Inc. Detections/Traversals: Base (1 report): _____; FU Alarms/Traversals: _____ Base (3 report): _____; FU Alarms/Traversals: _____ Adj. (1 report): _____; FU Alarms/Traversals: _____ Adj. (3 report): _____; FU Alarms/Traversals: _____ Other observations (Short link, data problems, etc.; use lines as needed) | |

| | |
|---|---|
| NU Inc. #: <u>16</u> | NWCD Incident #: <u>None</u> |
| Date: <u>11/14/95</u> First report: <u>16:30</u> Clear: <u>19:00</u> | |
| Type: <u>Short Term Const.</u> | Inc. Location: <u>Hintz, S. Acco Plaza & Old Wolf</u> |
| Incident PV IDs: <u>14</u> , _____, _____, _____ | |
| Follow-up PV IDs: Date: _____; _____, _____, _____, _____ Date: _____; _____, _____, _____, _____ Date: _____; _____, _____, _____, _____ Date: _____; _____, _____, _____, _____ | |
| Use distinct block for each link (and turning movement) | |
| Segment #: _____ Direction: _____ | |
| Link Location: (Incident, Upstream, Downstream): _____ Turn: _____ | |
| Inc. Detections/Traversals: Base (1 report): _____; FU Alarms/Traversals: _____ Base (3 report): _____; FU Alarms/Traversals: _____ Adj. (1 report): _____; FU Alarms/Traversals: _____ Adj. (3 report): _____; FU Alarms/Traversals: _____ | |
| Other observations (Short link, data problems, etc.; use lines as needed) | |
| Segment #: _____ Direction: _____ | |
| Link Location: (Incident, Upstream, Downstream): _____ Turn: _____ | |
| Inc. Detections/Traversals: Base (1 report): _____; FU Alarms/Traversals: _____ Base (3 report): _____; FU Alarms/Traversals: _____ Adj. (1 report): _____; FU Alarms/Traversals: _____ Adj. (3 report): _____; FU Alarms/Traversals: _____ | |
| Other observations (Short link, data problems, etc.; use lines as needed) | |
| Segment #: _____ Direction: _____ | |
| Link Location: (Incident, Upstream, Downstream): _____ Turn: _____ | |
| Inc. Detections/Traversals: Base (1 report): _____; FU Alarms/Traversals: _____ Base (3 report): _____; FU Alarms/Traversals: _____ Adj. (1 report): _____; FU Alarms/Traversals: _____ Adj. (3 report): _____; FU Alarms/Traversals: _____ | |
| Other observations (Short link, data problems, etc.; use lines as needed) | |

| | |
|--------------------------------|---|
| NU Inc. #: <u>16</u> | NWCD Incident #: <u>None</u> |
| Date: <u>11/14/95</u> | First report: <u>16:30</u> Clear: <u>19:00</u> |
| Type: <u>Short Term Const.</u> | Inc. Location: <u>Hintz, S. Acco Plaza & Old Wolf</u> |

| |
|---|
| Segment #: _____ Direction: _____ Link Location: (Incident, Upstream, Downstream): _____ Turn: _____ Inc. Detections/Traversals: Base (1 report): _____; FU Alarms/Traversals: _____ Base (3 report): _____; FU Alarms/Traversals: _____ Adj. (1 report): _____; FU Alarms/Traversals: _____ Adj. (3 report): _____; FU Alarms/Traversals: _____ Other observations (Short link, data problems, etc.; use lines as needed) |
| Segment #: _____ Direction: _____ Link Location: (Incident, Upstream, Downstream): _____ Turn: _____ Inc. Detections/Traversals: Base (1 report): _____; FU Alarms/Traversals: _____ Base (3 report): _____; FU Alarms/Traversals: _____ Adj. (1 report): _____; FU Alarms/Traversals: _____ Adj. (3 report): _____; FU Alarms/Traversals: _____ Other observations (Short link, data problems, etc.; use lines as needed) |
| Segment #: _____ Direction: _____ Link Location: (Incident, Upstream, Downstream): _____ Turn: _____ Inc. Detections/Traversals: Base (1 report): _____; FU Alarms/Traversals: _____ Base (3 report): _____; FU Alarms/Traversals: _____ Adj. (1 report): _____; FU Alarms/Traversals: _____ Adj. (3 report): _____; FU Alarms/Traversals: _____ Other observations (Short link, data problems, etc.; use lines as needed) |

| | |
|--|---|
| NU Inc. #: <u>17</u> | NWCD Incident #: <u>EGP9551591 (EGF9504823)</u> |
| Date: <u>11/16/95</u> | First report: <u>18:10</u> Clear: <u>19:09</u> |
| Type: <u>ACPI</u> | Inc. Location: <u>NB Elmhurst, Elmhurst & Greenleaf</u> |
| Incident PV IDs: <u>11</u> , _____, _____, _____ | |
| Follow-up PV IDs: Date: <u>11/20</u> ; <u>0B</u> , <u>14</u> , <u>19</u> , _____ Date: _____; _____, _____, _____, _____ Date: _____; _____, _____, _____, _____ Date: _____; _____, _____, _____, _____ | |
| Use distinct block for each link (and turning movement) | |
| Segment #: <u>90f1a-90d61</u> Direction: <u>NB</u> Link Location: (Incident, Upstream, Downstream): <u>INC</u> Turn: <u>Through</u> Inc. Detections/Traversals: Base (1 report): <u>2/3</u> ; FU Alarms/Traversals: <u>0/18</u> Base (3 report): <u>1/1</u> ; FU Alarms/Traversals: <u>0/16</u> Adj. (1 report): <u>1/3</u> ; FU Alarms/Traversals: <u>0/18</u> Adj. (3 report): <u>1/1</u> ; FU Alarms/Traversals: <u>0/16</u> Other observations (Short link, data problems, etc.; use lines as needed) | |
| Segment #: <u>890f1a-8a5c5e</u> Direction: <u>SB</u> Link Location: (Incident, Upstream, Downstream): <u>INC</u> Turn: <u>Through</u> Inc. Detections/Traversals: Base (1 report): <u>0/1</u> ; FU Alarms/Traversals: <u>N/A</u> Base (3 report): _____; FU Alarms/Traversals: _____ Adj. (1 report): _____; FU Alarms/Traversals: _____ Adj. (3 report): _____; FU Alarms/Traversals: _____ Other observations (Short link, data problems, etc.; use lines as needed): <u>No FU traversals.</u> | |
| Segment #: <u>890f1a-a5c28</u> Direction: <u>SB</u> Link Location: (Incident, Upstream, Downstream): <u>INC</u> Turn: <u>Turn</u> Inc. Detections/Traversals: Base (1 report): <u>0/1</u> ; FU Alarms/Traversals: <u>N/A</u> Base (3 report): _____; FU Alarms/Traversals: _____ Adj. (1 report): _____; FU Alarms/Traversals: _____ Adj. (3 report): _____; FU Alarms/Traversals: _____ Other observations (Short link, data problems, etc.; use lines as needed): <u>No FU traversals.</u> | |

| | |
|--|---|
| NU Inc. #: <u>17</u> | NWCD Incident #: <u>EGP9551591 (EGF9504823)</u> |
| Date: <u>11/16/95</u> | First report: <u>18:10</u> Clear: <u>19:09</u> |
| Type: <u>ACPI</u> | Inc. Location: <u>NB Elmhurst, Elmhurst & Greenleaf</u> |
| Segment #: <u>890d61-890f1a</u> Direction: <u>SB</u> Link Location: (Incident, Upstream, Downstream): <u>UP1</u> Turn: <u>Through</u> Inc. Detections/Traversals: Base (1 report): <u>0/2</u> ; FU Alarms/Traversals: <u>N/A</u> Base (3 report): _____ ; FU Alarms/Traversals: _____ Adj. (1 report): _____ ; FU Alarms/Traversals: _____ Adj. (3 report): _____ ; FU Alarms/Traversals: _____ Other observations (Short link, data problems, etc.; use lines as needed): <u>No FU traversals.</u> | |

| | |
|--|--|
| NU Inc. #: <u>18</u> | NWCD Incident #: <u>None</u> |
| Date: <u>11/16/95</u> | First report: <u>17:40</u> Clear: <u>18:10 (moved to shoulder)</u> |
| Type: <u>Stalled Truck</u> | Inc. Location: <u>SB Busse, Busse & Mark</u> |
| Incident PV IDs: <u>11</u> , <u>32</u> , _____, _____ | |
| Follow-up PV IDs: Date: <u>11/20</u> ; <u>0B</u> , <u>14</u> , <u>19</u> , _____ Date: _____; _____, _____, _____, _____ Date: _____; _____, _____, _____, _____ Date: _____; _____, _____, _____, _____ | |
| Use distinct block for each link (and turning movement) | |
| Segment #: <u>8a60c6-a6381</u> Direction: <u>SB</u> Link Location: (Incident, Upstream, Downstream): <u>INC</u> Turn: <u>Through</u> Inc. Detections/Traversals: Base (1 report): <u>4/8</u> ; FU Alarms/Traversals: <u>1/9</u> Base (3 report): <u>4/6</u> ; FU Alarms/Traversals: <u>3/7</u> Adj. (1 report): <u>2/8</u> ; FU Alarms/Traversals: <u>1/9</u> Adj. (3 report): <u>2/6</u> ; FU Alarms/Traversals: <u>0/7</u> Other observations (Short link, data problems, etc.; use lines as needed) | |
| Segment #: <u>8a5dff-8a60c6</u> Direction: <u>SB</u> Link Location: (Incident, Upstream, Downstream): <u>UP1</u> Turn: <u>Through</u> Inc. Detections/Traversals: Base (1 report): <u>1/8</u> ; FU Alarms/Traversals: <u>0/18</u> Base (3 report): <u>0/6</u> ; FU Alarms/Traversals: <u>0/16</u> Adj. (1 report): <u>2/8</u> ; FU Alarms/Traversals: <u>0/18</u> Adj. (3 report): <u>1/6</u> ; FU Alarms/Traversals: <u>0/16</u> Other observations (Short link, data problems, etc.; use lines as needed) | |
| Segment #: <u>a6381-8a63e0</u> Direction: <u>SB</u> Link Location: (Incident, Upstream, Downstream): <u>DN1</u> Turn: <u>Turn</u> Inc. Detections/Traversals: Base (1 report): <u>1/2</u> ; FU Alarms/Traversals: <u>11/15</u> Base (3 report): _____; FU Alarms/Traversals: <u>13/13</u> Adj. (1 report): <u>0/2</u> ; FU Alarms/Traversals: <u>0/15</u> Adj. (3 report): _____; FU Alarms/Traversals: <u>0/13</u> Other observations (Short link, data problems, etc.; use lines as needed): <u>Short link combined; several erratic CTTs in both Inc. & FU traversals.</u> | |

| | |
|---|--|
| NU Inc. #: <u>18</u> | NWCD Incident #: <u>None</u> |
| Date: <u>11/16/95</u> | First report: <u>17:40</u> Clear: <u>18:10 (moved to shoulder)</u> |
| Type: <u>Stalled Truck</u> | Inc. Location: <u>SB Busse, Busse & Mark</u> |
| Segment #: <u>126c5d-a60c6</u> Direction: <u>NB</u> Link Location: (Incident, Upstream, Downstream): <u>INC</u> Turn: <u>Through</u> Inc. Detections/Traversals: Base (1 report): <u>0/6</u> ; FU Alarms/Traversals: <u>N/A</u> Base (3 report): <u>0/4</u> ; FU Alarms/Traversals: _____ Adj. (1 report): _____; FU Alarms/Traversals: _____ Adj. (3 report): _____; FU Alarms/Traversals: _____ Other observations (Short link, data problems, etc.; use lines as needed): <u>No FU traversals.</u> | |
| Segment #: <u>8a673a-126c5d</u> Direction: <u>NB</u> Link Location: (Incident, Upstream, Downstream): <u>UP1</u> Turn: <u>Through</u> Inc. Detections/Traversals: Base (1 report): <u>0/6</u> ; FU Alarms/Traversals: <u>N/A</u> Base (3 report): <u>0/4</u> ; FU Alarms/Traversals: _____ Adj. (1 report): _____; FU Alarms/Traversals: _____ Adj. (3 report): _____; FU Alarms/Traversals: _____ Other observations (Short link, data problems, etc.; use lines as needed): <u>No FU traversals.</u> | |

| | |
|--|---|
| NU Inc. #: <u>19</u> | NWCD Incident #: <u>AHP9536477</u> |
| Date: <u>08/22/95</u> | First report: <u>18:24</u> Clear: <u>18:49</u> |
| Type: <u>Motorist Assistance</u> | Inc. Location: <u>Dundee & Wilke</u> |
| Incident PV IDs: <u>1B</u> , <u>11</u> , _____, _____ | |
| Follow-up PV IDs: | |
| Date: <u>08/11</u> ; | <u>42</u> , <u>50</u> , _____, _____ |
| Date: <u>08/14</u> ; | <u>69</u> , <u>5C</u> , <u>3E</u> , <u>17</u> |
| Date: <u>08/15</u> ; | <u>37</u> , <u>32</u> , <u>10</u> , <u>59</u> , <u>2B</u> , <u>19</u> |
| Date: <u>08/16</u> ; | <u>11</u> , <u>17</u> , <u>19</u> , <u>50</u> , <u>0B</u> , <u>0D</u> , <u>1A</u> |
| Date: <u>08/21</u> ; | <u>0B</u> , <u>14</u> , <u>19</u> , _____ |
| Date: <u>08/23</u> ; | <u>0A</u> , <u>1B</u> , _____, _____ |
| Date: <u>08/24</u> ; | <u>10</u> , <u>2B</u> , <u>57</u> , _____ |
| Date: <u>08/25</u> ; | <u>5C</u> , <u>59</u> , <u>10</u> , _____ |
| Date: <u>11/07</u> ; | <u>11</u> , <u>1B</u> , _____, _____ |
| Date: <u>11/08</u> ; | <u>11</u> , <u>52</u> , _____, _____ |
| Date: <u>11/15</u> ; | <u>16</u> , <u>52</u> , _____, _____ |
| Date: <u>11/16</u> ; | <u>16</u> , _____, _____, _____ |
| Date: <u>11/17</u> ; | <u>17</u> , _____, _____, _____ |
| Use distinct block for each link (and turning movement) | |
| Segment #: <u>8cb09-8cb0a</u> Direction: <u>WB</u> | |
| Link Location: (Incident, Upstream, Downstream): <u>INC</u> Turn: <u>Through</u> | |
| Inc. Detections/Traversals: | |
| Base (1 report): <u>2/2</u> ; | FU Alarms/Traversals: <u>0/63</u> |
| Base (3 report): _____ ; | FU Alarms/Traversals: <u>0/61</u> |
| Adj. (1 report): _____ ; | FU Alarms/Traversals: _____ |
| Adj. (3 report): _____ ; | FU Alarms/Traversals: _____ |
| Other observations (Short link, data problems, etc.; use lines as needed) | |
| Segment #: <u>8cb07-8cb09</u> Direction: <u>WB</u> | |
| Link Location: (Incident, Upstream, Downstream): <u>UP1</u> Turn: <u>Through</u> | |
| Inc. Detections/Traversals: | |
| Base (1 report): <u>1/3</u> ; | FU Alarms/Traversals: <u>0/89</u> |
| Base (3 report): <u>1/1</u> ; | FU Alarms/Traversals: <u>0/87</u> |
| Adj. (1 report): <u>0/3</u> ; | FU Alarms/Traversals: <u>0/89</u> |
| Adj. (3 report): <u>0/1</u> ; | FU Alarms/Traversals: <u>0/87</u> |
| Other observations (Short link, data problems, etc.; use lines as needed) | |

| | |
|--|--|
| NU Inc. #: <u>19</u> | NWCD Incident #: <u>AHP9536477</u> |
| Date: <u>08/22/95</u> | First report: <u>18:24</u> Clear: <u>18:49</u> |
| Type: <u>Motorist Assistance</u> | Inc. Location: <u>Dundee & Wilke</u> |
| Segment #: <u>88cb0a-88cb09</u> Direction: <u>EB</u> Link Location: (Incident, Upstream, Downstream): <u>INC</u> Turn: <u>Through</u> Inc. Detections/Traversals: Base (1 report): <u>0/1</u> ; FU Alarms/Traversals: <u>7/64</u> Base (3 report): _____; FU Alarms/Traversals: <u>5/62</u> Adj. (1 report): _____; FU Alarms/Traversals: _____ Adj. (3 report): _____; FU Alarms/Traversals: _____ Other observations (Short link, data problems, etc.; use lines as needed): <u>Short link? Signal?</u> | |
| Segment #: <u>89d42f-88cb0a</u> Direction: <u>EB</u> Link Location: (Incident, Upstream, Downstream): <u>UPI</u> Turn: <u>Through</u> Inc. Detections/Traversals: Base (1 report): <u>0/1</u> ; FU Alarms/Traversals: <u>0/70</u> Base (3 report): _____; FU Alarms/Traversals: <u>0/68</u> Adj. (1 report): _____; FU Alarms/Traversals: _____ Adj. (3 report): _____; FU Alarms/Traversals: _____ Other observations (Short link, data problems, etc.; use lines as needed) | |

| | |
|--|--|
| NU Inc. #: <u>20</u> | NWCD Incident #: <u>AHP9536477</u> |
| Date: <u>08/24/95</u> | First report: <u>15:29</u> Clear: <u>16:53</u> |
| Type: <u>ACPD</u> | Inc. Location: <u>Higgins & Lively</u> |
| Incident PV IDs: <u>17</u> , <u>14</u> , _____, _____ | |
| Follow-up PV IDs: | |
| Date: <u>11/07</u> ; | <u>16</u> , <u>09</u> , <u>52</u> , <u>5A</u> |
| Date: <u>11/08</u> ; | <u>19</u> , <u>16</u> , <u>0B</u> , _____ |
| Date: <u>11/09</u> ; | <u>19</u> , _____, _____, _____ |
| Date: <u>11/14</u> ; | <u>09</u> , <u>2B</u> , _____, _____ |
| Date: <u>11/15</u> ; | <u>57</u> , <u>5A</u> , _____, _____ |
| Date: <u>11/16</u> ; | <u>14</u> , <u>11</u> , <u>1B</u> , _____ |
| Date: <u>11/17</u> ; | <u>14</u> , <u>5A</u> , <u>2B</u> , _____ |
| Date: <u>11/21</u> ; | <u>14</u> , _____, _____, _____ |
| Use distinct block for each link (and turning movement) | |
| Segment #: <u>890406-890458</u> Direction: <u>SEB</u> | |
| Link Location: (Incident, Upstream, Downstream): <u>INC</u> Turn: <u>Through</u> | |
| Inc. Detections/Traversals: | |
| Base (1 report): <u>0/2</u> ; | FU Alarms/Traversals: <u>0/61</u> |
| Base (3 report): _____ ; | FU Alarms/Traversals: <u>0/59</u> |
| Adj. (1 report): <u>0/2</u> ; | FU Alarms/Traversals: <u>1/61</u> |
| Adj. (3 report): _____ ; | FU Alarms/Traversals: <u>0/59</u> |
| Other observations (Short link, data problems, etc.; use lines as needed): | |
| Segment #: <u>890313-890406</u> Direction: <u>EB</u> | |
| Link Location: (Incident, Upstream, Downstream): <u>UP1</u> Turn: <u>Through</u> | |
| Inc. Detections/Traversals: | |
| Base (1 report): <u>0/2</u> ; | FU Alarms/Traversals: <u>0/69</u> |
| Base (3 report): _____ ; | FU Alarms/Traversals: <u>0/67</u> |
| Adj. (1 report): <u>0/2</u> ; | FU Alarms/Traversals: <u>0/69</u> |
| Adj. (3 report): _____ ; | FU Alarms/Traversals: <u>0/67</u> |
| Other observations (Short link, data problems, etc.; use lines as needed): | |
| Segment #: <u>890458-9e713</u> Direction: <u>EB</u> | |
| Link Location: (Incident, Upstream, Downstream): <u>DN1</u> Turn: <u>Through</u> | |
| Inc. Detections/Traversals: | |
| Base (1 report): <u>1/2</u> ; | FU Alarms/Traversals: <u>0/60</u> |
| Base (3 report): _____ ; | FU Alarms/Traversals: <u>0/58</u> |
| Adj. (1 report): <u>2/2</u> ; | FU Alarms/Traversals: <u>0/60</u> |
| Adj. (3 report): _____ ; | FU Alarms/Traversals: <u>0/68</u> |
| Other observations (Short link, data problems, etc.; use lines as needed): | |

| | |
|---|--|
| NU Inc. #: <u>21</u> | NWCD Incident #: <u>AHP9549518</u> |
| Date: <u>11/16/95</u> First report: <u>13:19</u> Clear: <u>16:04</u> | |
| Type: <u>LMAL</u> | Inc. Location: <u>Algonquin & Arlington Hts.</u> |
| Incident PV IDs: <u>1B</u> , <u>09</u> , <u>32</u> , <u>14</u> | |
| Follow-up PV IDs: | |
| Date: <u>11/07</u> ; | <u>0B</u> , _____, _____, _____ |
| Date: <u>11/08</u> ; | <u>0A</u> , <u>0B</u> , _____, _____ |
| Date: <u>11/09</u> ; | <u>1B</u> , <u>11</u> , <u>19</u> , <u>57</u> |
| Date: <u>11/13</u> ; | <u>0B</u> , <u>2B</u> , _____, _____ |
| Date: <u>11/14</u> ; | <u>2B</u> , <u>32</u> , _____, _____ |
| Date: <u>11/15</u> ; | <u>0B</u> , <u>0D</u> , _____, _____ |
| Date: <u>11/17</u> ; | <u>1B</u> , <u>4B</u> , <u>09</u> , _____ |
| Date: <u>11/21</u> ; | <u>19</u> , <u>44</u> , _____, _____ |
| Use distinct block for each link (and turning movement) | |
| Segment #: <u>ce8a8-8f78c</u> Direction: <u>WB</u> | |
| Link Location: (Incident, Upstream, Downstream): <u>INC</u> Turn: <u>Through</u> | |
| Inc. Detections/Traversals: | |
| Base (1 report): <u>3/3</u> ; | FU Alarms/Traversals: <u>6/54</u> |
| Base (3 report): <u>1/1</u> ; | FU Alarms/Traversals: <u>4/52</u> |
| Adj. (1 report): <u>3/3</u> ; | FU Alarms/Traversals: <u>0/54</u> |
| Adj. (3 report): <u>1/1</u> ; | FU Alarms/Traversals: <u>0/52</u> |
| Other observations (Short link, data problems, etc.; use lines as needed) | |
| Segment #: <u>8f78c-8fc60</u> Direction: <u>NWB</u> | |
| Link Location: (Incident, Upstream, Downstream): <u>DN1</u> Turn: <u>Through</u> | |
| Inc. Detections/Traversals: | |
| Base (1 report): <u>0/5</u> ; | FU Alarms/Traversals: <u>3/15</u> |
| Base (3 report): <u>0/3</u> ; | FU Alarms/Traversals: <u>0/13</u> |
| Adj. (1 report): <u>0/5</u> ; | FU Alarms/Traversals: <u>0/15</u> |
| Adj. (3 report): <u>0/3</u> ; | FU Alarms/Traversals: <u>0/13</u> |
| Other observations (Short link, data problems, etc.; use lines as needed): <u>Short link combined</u> | |

| | |
|--|--|
| NU Inc. #: <u>21</u> | NWCD Incident #: <u>AHP9549518</u> |
| Date: <u>11/16/95</u> | First report: <u>13:19</u> Clear: <u>16:04</u> |
| Type: <u>LMAL</u> | Inc. Location: <u>Algonquin & Arlington Hts.</u> |
| Segment #: <u>88f78c-8ce8a8</u> | Direction: <u>SB</u> |
| Link Location: (Incident, Upstream, Downstream): <u>INC</u> | Turn: <u>Through</u> |
| Inc. Detections/Traversals: | |
| Base (1 report): <u>3/7</u> ; | FU Alarms/Traversals: <u>1/34</u> |
| Base (3 report): <u>4/5</u> ; | FU Alarms/Traversals: <u>3/32</u> |
| Adj. (1 report): <u>0/7</u> ; | FU Alarms/Traversals: <u>2/34</u> |
| Adj. (3 report): <u>0/5</u> ; | FU Alarms/Traversals: <u>0/32</u> |
| Other observations (Short link, data problems, etc.; use lines as needed): | |