



THE ROLLING RESISTANCE OF PNEUMATIC TIRES

S.K. Clark
R.N. Dodge

THE REGENTS OF THE UNIVERSITY OF MICHIGAN
Ann Arbor MI 48109



DECEMBER 1979

FINAL REPORT

DOCUMENT IS AVAILABLE TO THE PUBLIC
THROUGH THE NATIONAL TECHNICAL
INFORMATION SERVICE, SPRINGFIELD,
VIRGINIA 22161

PREPARED FOR
U.S. DEPARTMENT OF TRANSPORTATION
National Highway Traffic Safety Administration
Office of Research and Development
Washington DC 20590

REPRODUCED BY
NATIONAL TECHNICAL
INFORMATION SERVICE
U.S. DEPARTMENT OF COMMERCE
SPRINGFIELD, VA. 22161

NOTICE

This document is disseminated under the sponsorship of the Department of Transportation in the interest of information exchange. The United States Government assumes no liability for its contents or use thereof.

NOTICE

The United States Government does not endorse products or manufacturers. Trade or manufacturers' names appear herein solely because they are considered essential to the object of this report.

1. Report No. DOT-HS-804 523		2. Government Accession No.		3. Recipient's Catalog No.	
4. Title and Subtitle THE ROLLING RESISTANCE OF PENUMATIC TIRES				5. Report Date December 1979	
				6. Performing Organization Code	
7. Author(s) S. K. Clark, R. N. Dodge				8. Performing Organization Report No. DOT-TSC-NHTSA-79-28	
9. Performing Organization Name and Address The Regents of the University of Michigan* Ann Arbor MI 48109				10. Work Unit No. (TRAIS) HS027/R0404	
				11. Contract or Grant No. DOT-TSC-1031	
12. Sponsoring Agency Name and Address U.S. Department of Transportation National Highway Traffic Safety Administration Office of Research and Development Washington DC 20590				13. Type of Report and Period Covered Final Report	
				14. Sponsoring Agency Code	
15. Supplementary Notes *Under contract to: U.S. Department of Transportation Research and Special Programs Administration Transportation Systems Center Kendall Square, Cambridge MA 0					
16. Abstract This report illustrates the important variables which affect passenger car tire rolling resistance. The influence of speed, load and inflation pressure is discussed, and test data is presented on the influence of these. The test data encompasses a wide variety of modern tires, bias and radial, over a range of rim diameters and tire aspect ratios. Measurements of tire rolling resistance are discussed and equations presented for converting rolling resistance gotten on drums to the equivalent value on the road.					
17. Key Words Tire Rolling Resistance Measurements Fuel Economy			18. Distribution Statement Document is available to the public through the National Technical Information Service, Springfield, Virginia 22151		
19. Security Classif. (of this report) Unclassified		20. Security Classif. (of this page) Unclassified		21. No. of Pages 72	22. Price



NOTICE

THIS DOCUMENT HAS BEEN REPRODUCED FROM THE BEST COPY FURNISHED US BY THE SPONSORING AGENCY. ALTHOUGH IT IS RECOGNIZED THAT CERTAIN PORTIONS ARE ILLEGIBLE, IT IS BEING RELEASED IN THE INTEREST OF MAKING AVAILABLE AS MUCH INFORMATION AS POSSIBLE.

PREFACE

The purpose of this report is to describe the mechanics of tire rolling loss sufficiently so that those interested in understanding fuel consumption in vehicles may make comparative assessments of potential tires for given vehicle weights, tire inflation pressures, and tire construction features.

Since tire construction details are subject to change, it should be understood that the data given here are probably more valuable in indicating trends than in giving exact numerical values for the rolling resistance of current production tires.

The authors would like to acknowledge the financial support of the United States Department of Transportation for the funds which made this work possible. We would also like to thank Mr. Stephen Bobo, Technical Monitor, for originating this concept and for many suggestions as to the format and content of it.

The data quoted in this report was obtained by the B. F. Goodrich Research Laboratory and thanks are due to Dr. Marion Pottinger and Mr. David Strelow for their very careful and accurate measurement procedures.

METRIC CONVERSION FACTORS

Approximate Conversions to Metric Measures				Approximate Conversions from Metric Measures			
Symbol	When You Know	Multiply by	To Find	Symbol	When You Know	Multiply by	To Find
LENGTH							
in	inches	2.5	Centimeters	mm	millimeters	0.04	inches
ft	feet	30	Centimeters	cm	centimeters	0.4	inches
yd	yards	0.9	Meters	m	meters	3.3	feet
mi	miles	1.6	Kilometers	km	kilometers	0.6	miles
AREA							
sq in	square inches	6.5	square centimeters	cm ²	square centimeters	0.16	square inches
sq ft	square feet	0.09	square meters	m ²	square meters	1.2	square yards
sq yd	square yards	0.8	square meters	m ²	square kilometers	0.4	square miles
sq mi	square miles	2.6	square kilometers	km ²	hectares (10,000 m ²)	2.5	acres
MASS (weight)							
oz	ounces	28	grams	g	grams	0.035	ounces
lb	pounds	0.46	Kilograms	kg	kilograms	2.2	pounds
	short tons (2000 lb)	0.9	tonnes (1000 kg)	t	tonnes (1000 kg)	1.1	short tons
VOLUME							
teaspoon	teaspoons	5	milliliters	ml	milliliters	0.03	fluid ounces
tablespoon	tablespoons	15	milliliters	ml	liters	2.1	pints
fluid ounce	fluid ounces	30	milliliters	ml	liters	1.06	quarts
cup	cups	0.24	liters	l	liters	0.26	gallons
pint	pints	0.47	liters	l	cubic meters	35	cubic feet
quart	quarts	0.95	liters	l	cubic meters	1.3	cubic yards
gallon	gallons	3.8	liters	l			
cubic foot	cubic feet	0.03	cubic meters	m ³			
cubic yard	cubic yards	0.76	cubic meters	m ³			
TEMPERATURE (exact)							
F	Fahrenheit temperature	5/9 (after subtracting 32)	Celsius temperature	C	Celsius temperature	9/5 (then add 32)	Fahrenheit temperature

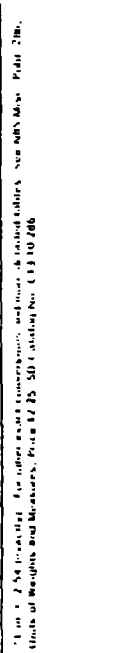

* In U.S. 254 (revised), for other exact conversions, and more detailed tables, see NBS Monograph 286, Guide for the Use of the International System of Units, NIST, Gaithersburg, MD, 1975.

TABLE OF CONTENTS

<u>Section</u>	<u>Page</u>
1. INTRODUCTION	1
2. FUNDAMENTALS OF ROLLING LOSS	2
3. EFFECT OF OPERATING VARIABLES	5
4. MEASUREMENT METHODS AND DATA REDUCTION IN ROLLING LOSS MEASUREMENTS	39
4.1 Stress Effects	39
4.2 Measurement Geometry	39
4.3 Combined Effects	40
5. DESCRIPTION OF TEST METHODS	47
6. BIBLIOGRAPHY	48
APPENDIX - MEASUREMENT METHODS AND DATA REDUCTION IN ROLLING LOSS MEASUREMENTS	49

LIST OF ILLUSTRATIONS

<u>Figure</u>	<u>Page</u>
1. A Typical Stress Strain Curve Illustrating Loss	3
2. Influence of Temperature on the Loss Characteristics of a Typical Rubber Compound	3
3. Typical Rolling Resistance vs. Time Variation	6
4. Rolling Resistance vs. Vertical Load for G78-14 Bias Tire	7
5. Rolling Resistance vs. Vertical Load for H78-15 Bias Tire	8
6. Rolling Resistance vs. Vertical Load for GR78-14 Radial Tire	9
7. Rolling Resistance vs. Vertical Load for HR78-15 Radial Tire	10
8. Coefficient of Rolling Resistance vs. Vertical Load for G78-14 Bias Tire	12
9. Coefficient of Rolling Resistance vs. Vertical Load for H78-15 Bias Tire	13
10. Coefficient of Rolling Resistance vs. Vertical Load for GR78-14 Radial Tire	14
11. Coefficient of Rolling Resistance vs. Vertical Load for HR78-15 Radial Tire	15
12. Rolling Resistance and Coefficient of Rolling Resistance vs. Reciprocal of Inflation Pressure for G78-14 Bias Tire	16
13. Rolling Resistance and Coefficient of Rolling Resistance vs. Reciprocal of Inflation Pressure for H78-15 Bias Tire	17
14. Rolling Resistance and Coefficient of Rolling Resistance vs. Reciprocal of Inflation Pressure for GR78-14 Radial Tire	18
15. Rolling Resistance and Coefficient of Rolling Resistance vs. Reciprocal of Inflation Pressure for HR78-15 Radial Tire	19
16. Rolling Resistance vs. Speed for a Group of Modern Passenger Car Tires	21
17. Rolling Resistance vs. Tire Load Rating for a Typical Selection of Passenger Car Tires	23

LIST OF ILLUSTRATIONS (CONTINUED)

<u>Figure</u>	<u>Page</u>
18. Coefficient of Rolling Resistance vs. Tire Load Rating for a Selection of Passenger Car Tires	27
19. Ratio of Equilibrium Rolling Resistance to Initial Rolling Resistance for a Selection of Passenger Car Tires	31
20. Rolling Resistance vs. Cooling Time for: (a) BR78-13 Radial Tire; (b) LR78-15 Radial Tire; (c) GR78-15 Radial Tire; (d) G78-15 Bias Tire; (e) A78-13 Bias Tire	32
21. Equilibrium Rolling Resistance Values for New, Worn, and Retreaded Tires of the Same Type	37
22. Carpet Plot of Rolling Resistance as a Function of Load and Pressure	42
23. Five Point Carpet Plot	42
24. Graphical Representation of the Slope Needed to Determine the Constant for Tire Predictions	44
A-1. Free Body Diagram of a Rolling Tire on a Flat Surface Under Applied Force	49
A-2. Free Body Diagram of a Rolling Tire on a Flat Surface Under Applied Torque	51
A-3. Free Body Diagram of a Powered Tire Driving a Vehicle	51
A-4. Resultant Forces on the Tire While Rolling on a Test Drum	53
A-5. Geometry of Tire and Test Drum	57
A-6. Typical Tire Cross-Sectional Geometry	58

LIST OF TABLES

<u>Table</u>	<u>Page</u>
I. Tire Identification and Test Data	24
II. Test Data for 7.00-15 LT Tire	28
III. Test Data for 8.00R 16.5 LT Tire	28
IV. Test Data for 8.75R 16.5 LT Tire	29
V. Test Data for 9.50-16.5 LT Tire	29
VI. Coefficient of Rolling Resistance for Light Truck Tires at Typical Loads and Pressures	29
VII. Equilibrium Rolling Resistance for Tires of Various Sizes Under the Same Load	38
VIII. Measured vs. Calculated Values of Equilibrium Rolling Resistance Using Eq. (10)	45
IX. Measured and Predicted Equilibrium Rolling Resistance Using Eq. (10)	46

NOMENCLATURE

General

- c_p, c_T - constants
- F_r - tire rolling resistance on highway, lb
- F_{xM} - tire rolling resistance as measured by axle force transducer, lb
- F_{xR} - tire rolling resistance when running on a cylindrical drum of radius, lb
- F_z - tire load, lb
- K_L, K_p - constants
- P_o - tire inflation pressure, psi, initial cold value
- R - drum radius
- r - tire radius
- r_L - tire loaded radius (axle height)
- r_r - tire rolling radius
- T - temperature
- t - time

Tire Construction

- | | |
|-----------------------|---------------|
| B - bias tire | N - nylon |
| BB - bias belted tire | P - polyester |
| R - radial tire | R - rayon |
| F - fiberglass | S - steel |
| H - high performance | |

KEY TO TIRE CONSTRUCTION NOTATION

Example

Bias Tires (B):

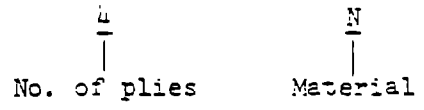

Bias Belted Tires (BB):

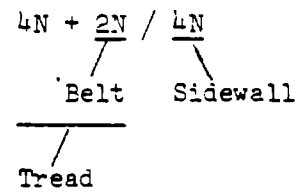

Radial Tires (R):

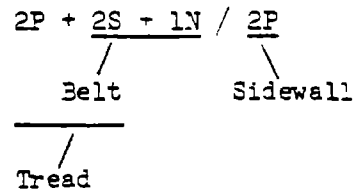



1. INTRODUCTION

Interest in fuel conservation and the national goal of more energy efficient passenger car vehicles has generated considerable interest in the phenomenon of the rolling resistance of pneumatic tires. It is generally recognized that the pneumatic tire represents one of the major loss mechanisms for the engine output of a vehicle, the other mechanisms being considered to be aerodynamic loss, transmission and drive train inefficiency, and the power needed for acceleration of the vehicle. The quantitative influence of tire rolling resistance on fuel consumption depends heavily on the vehicle and on the specific driving cycle. The most pertinent data, at least for passenger car tires, seems to be that of Ref. [1],* which shows that in the range of present commercial tire characteristics, and for most driving cycles, a 10% change in tire rolling resistance yields a 2% change in fuel economy. This is a ratio of 5:1 in sensitivity. However, this improvement factor decreases as tire loss becomes less when more fuel efficient tires have been developed, and are in use, their contribution to the overall fuel consumption of the vehicle will be small enough so that a much larger percentage change in tire rolling resistance will be required in order to achieve the same percentage change in fuel consumption.

Recent trip length studies [3],[4] show that the average trip length in the United States is less than 5 miles, and that over 40% of the vehicle miles traveled by passenger cars is for trips less than 5 miles. Even further, due to the temperature sensitivity of pneumatic tires, their rolling loss tends to be substantially higher in the winter months than in the summer months, and this factor, coupled with short trip lengths, means that a great deal of the passenger car vehicle travel in the United States is carried out under conditions when the tires account for a substantial part of the vehicle rolling resistance. Clearly, the role of the tire is a vital one in this problem, and probably is the single most important component outside of the engine which can be modified or improved to aid in the goal of reduced fuel consumption.

*Numbers in square brackets refer to the references in the Bibliography.

2. FUNDAMENTALS OF ROLLING LOSS

It is useful to think of the tires on the drive wheels of an automobile or truck as power transmission devices, since they transmit power from the engine to the roadway in order to propel the vehicle. This is accomplished with an efficiency which may vary from nearly 100% to zero, although under normal conditions of good traction and steady-state running the efficiency of the pneumatic tires is quite high, being of the same order of magnitude as that of other power transmission components in the vehicle say 0.98 to 0.99. The unpowered or free rolling wheels on a vehicle may be thought of as a special case of powered wheels, but now with zero torque applied from external sources.

The rolling loss of a tire is made up of three parts:

- (a) Friction or scrubbing between tire and roadway;
- (b) Windage loss of the tire; and
- (c) Hysteretic losses of the tire materials due to cyclic stressing. These have their origin in typical stress-strain curves such as shown in Figure 1, where the shaded area under the curve is the energy lost in one stress cycle.

In normal operation the tire loss is essentially all hysteretic, the ground friction and windage being negligible.

The hysteretic loss properties of almost all rubber compounds are quite temperature sensitive, being much larger at low temperatures than at high temperatures. This is illustrated in Figure 2. This means that tires have a much higher rolling loss when first starting from ambient temperature conditions than after warming up to equilibrium running temperatures. Further, the higher temperatures in the tire cause the air in the tire to increase in pressure, leading to reduced tire deflection and even further reductions in rolling loss. Because of these two effects acting together, tires show a significant reduction in rolling loss as they warm up. For passenger car tires this reduction is of the order of 1/3 of the initial rolling loss, and occurs over a 20- to 30-minute period.

On a passenger car vehicle every tire performs at least one other function than carrying its assigned share of the load. This may be either driving, in the case of the rear wheels, or steering in the case of the front wheels. Both of these effects obviously influence loss in the tire itself, and greatly complicate quantitative evaluation of one tire design against another. For that reason the present review will be restricted to free rolling tires in straight-line motion without steer or applied torque. This will give at least a base-line condition from which the performance of one tire may be judged against another in a relatively simple set of operating circumstances.

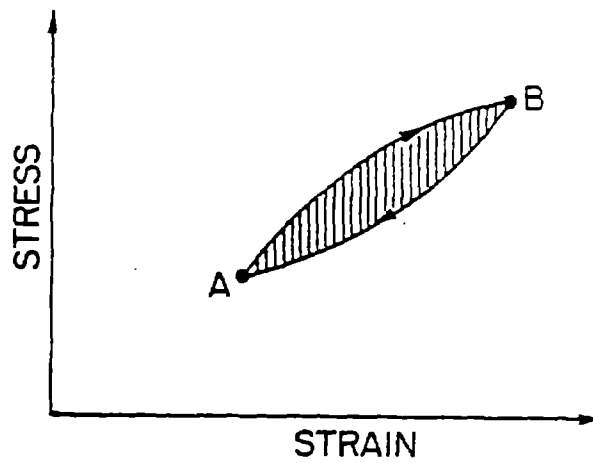

FIGURE 1. A TYPICAL STRESS STRAIN CURVE ILLUSTRATING LOSS

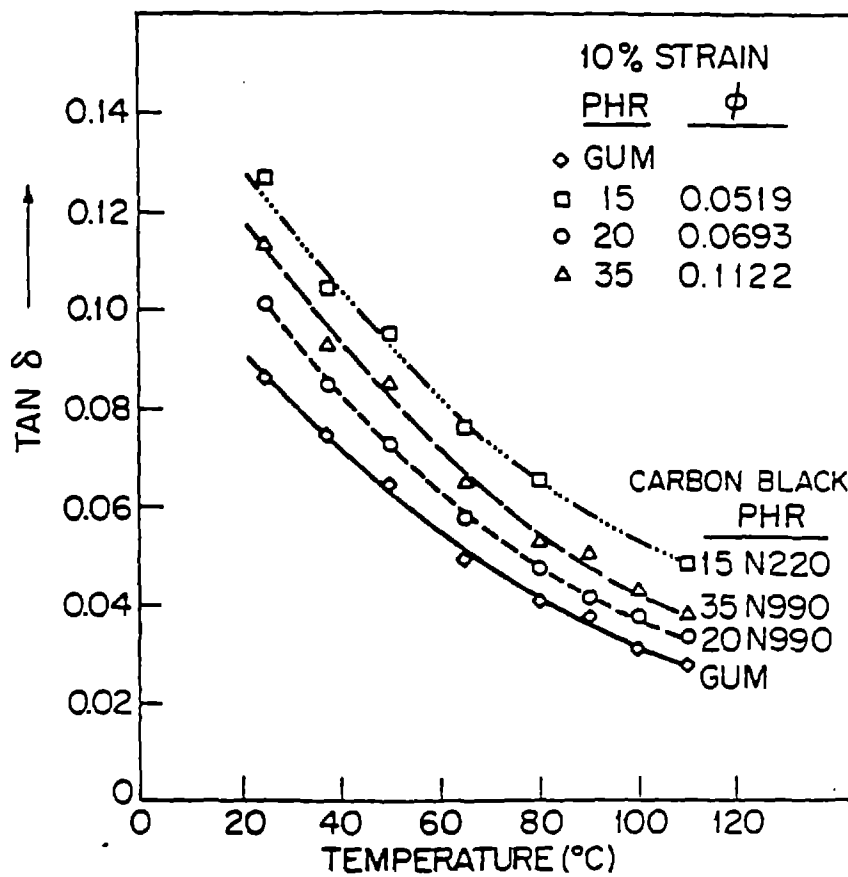

FIGURE 2. INFLUENCE OF TEMPERATURE ON THE LOSS CHARACTERISTICS OF A TYPICAL RUBBER COMPOUND

Even within the framework of the restrictions just stated, the rolling loss experienced by a pneumatic tire still is a function of the tire initial inflation pressure and temperature state, both of which depend not only on the length of time of running but also upon the detailed running history and ambient temperature, as well as the other operating parameters that normally control tire rolling resistance such as vehicle speed and weight. Thus the unambiguous description of the rolling loss of a pneumatic tire requires the complete specification of its operating characteristics. These will be discussed in the subsequent sections.

3. EFFECT OF OPERATING VARIABLES

Since all rubber compounds exhibit temperature sensitive loss characteristics, rolling resistance of a pneumatic tire depends on its operating temperature, which in turn is controlled by its inflation pressure, load, and the length of time which the tire has run. Usually the tire starts from a cold state when the vehicle begins a trip, and warms up due to internal hysteretic loss as the trip progresses. During the warm-up process the rolling resistance of the tire decreases, and eventually the tire reaches some near-equilibrium temperature provided that the vehicle is operated in a steady state condition, such as at constant speed on the highway. Under conditions of start and stop driving, such as in an urban environment, the tire is constantly changing temperature, but due to its poor thermal conductivity it does so with a relatively small set of perturbations about some average warm or hot state. The detailed description of such a temperature state is a function of the exact driving cycle and cannot be described specifically. It has been customary in the study of tire rolling resistance to evaluate this type of effect at some convenient constant speed in order to provide a base-line measurement against which one tire could be compared with another. This is probably as satisfactory a solution as can be obtained at this time for the effect of running time or trip length.

A typical plot of tire rolling resistance versus running time is shown in Figure 3 for Goodyear GR78-14 radial tire. This is typical of the kind of rolling resistance response to time which a pneumatic tire exhibits.

There has been considerable interest in the influence of load and running time on the rolling resistance of pneumatic tires, and Figures 4 - 7 present data on this subject for four common sizes of passenger car tires, these being G78-14 and H78-15 bias tires, and GR78-14 and HR78-15 radial tires. In this case the tire rolling resistance is plotted as a function of load carried, for the case where the cold inflation pressure is set prior to the beginning of the test. The rolling resistance is plotted at various values of time ranging from the initial or the starting value up to the equilibrium value.

It may be seen from these figures that there is a nearly linear relationship between the tire rolling resistance and the load for the equilibrium case, as illustrated in Figures 4 - 7. In all four of these sets of data the linear relationship between load and rolling resistance is very close, and further, to a very close approximation the rolling resistance vanishes at zero load, with a straight line drawn through the data points nearly intersecting the origin of rolling resistance and load. This is illustrated in Figures 4 - 7 by means of a dashed line extending from the data points to the zero load condition.

This data further shows that such a linear relationship is not true at the starting point, zero time. However, the tires tend to warm up rather quickly, with rolling resistance values at 5 and 10 minutes being very close to the equilibrium value, much closer than to the starting value. This means that analytical modeling of the pneumatic tire as a function of time for short trip

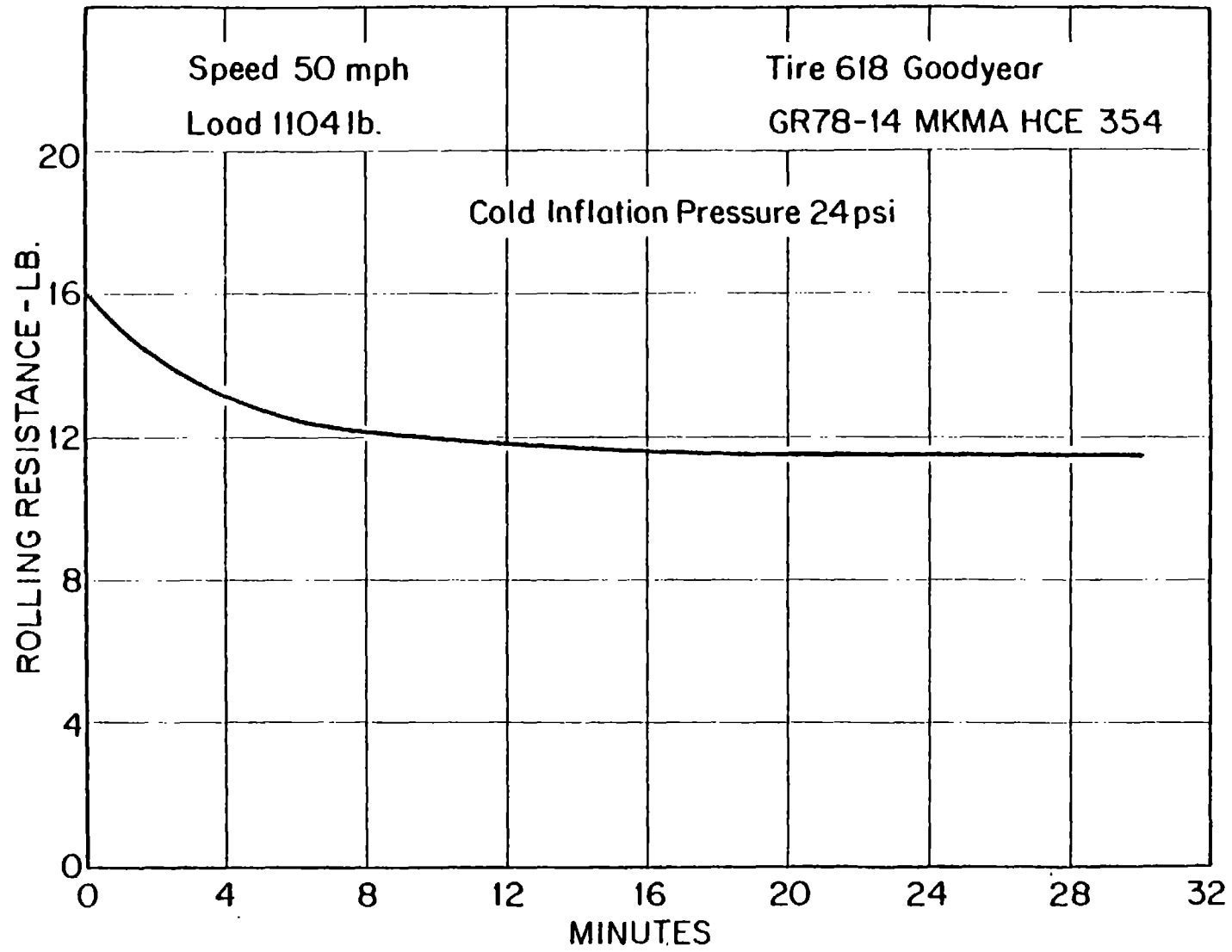

FIGURE 3. TYPICAL ROLLING RESISTANCE VS. TIME VARIATION

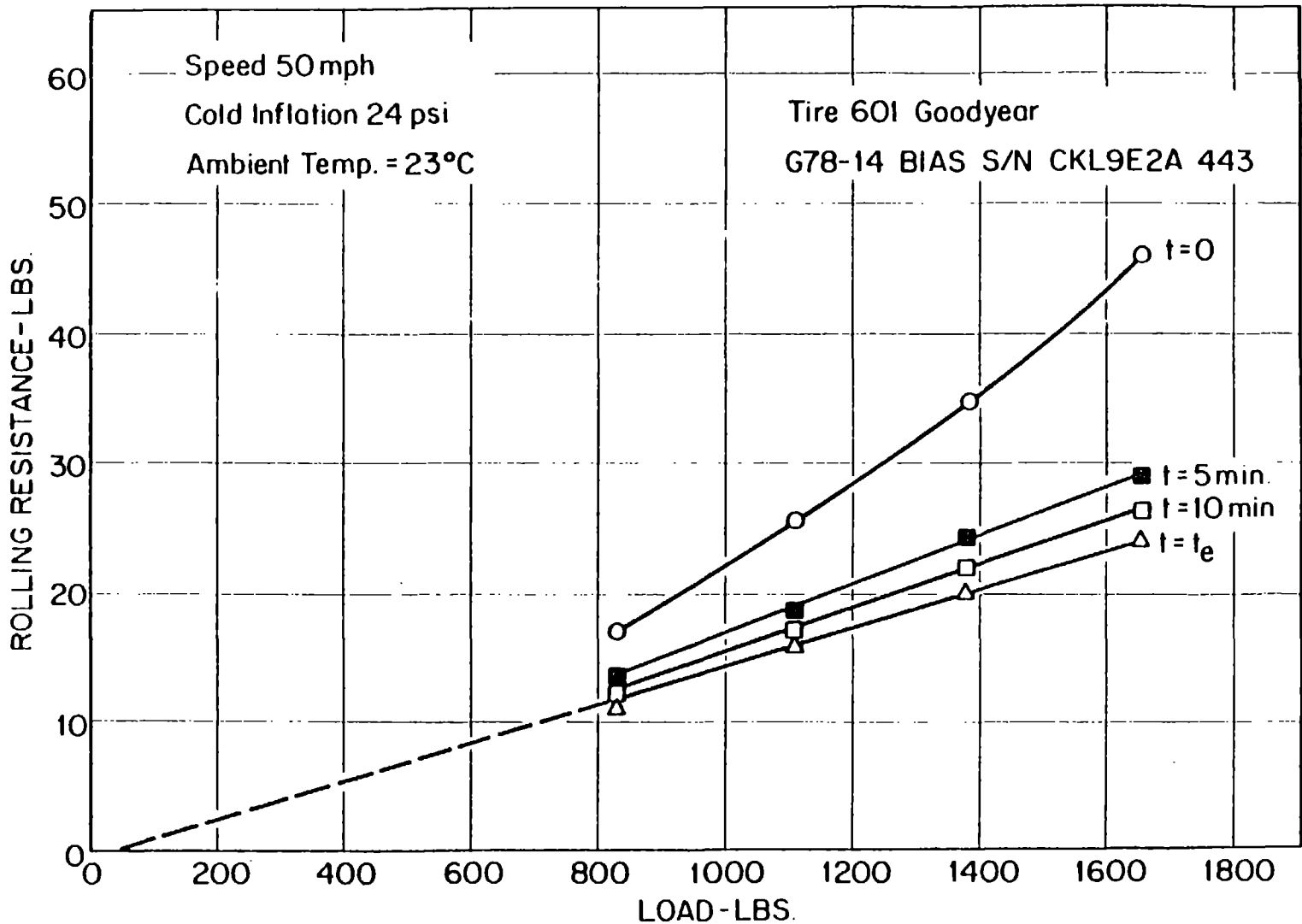

FIGURE 4. ROLLING RESISTANCE VS. VERTICAL LOAD FOR G78-14 BIAS TIRE

7

8

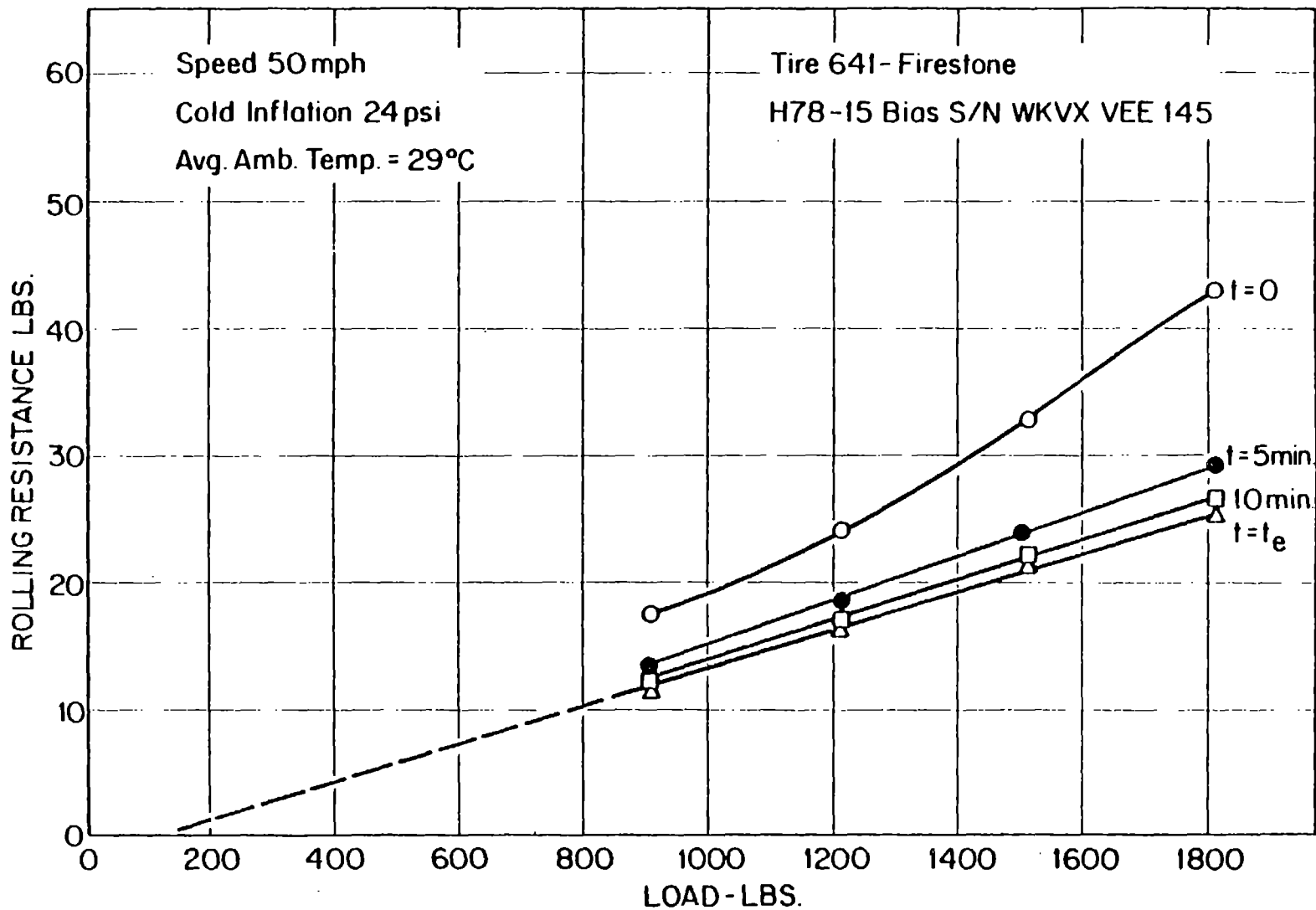

FIGURE 5. ROLLING RESISTANCE VS. VERTICAL LOAD FOR H78-15 BIAS TIRE

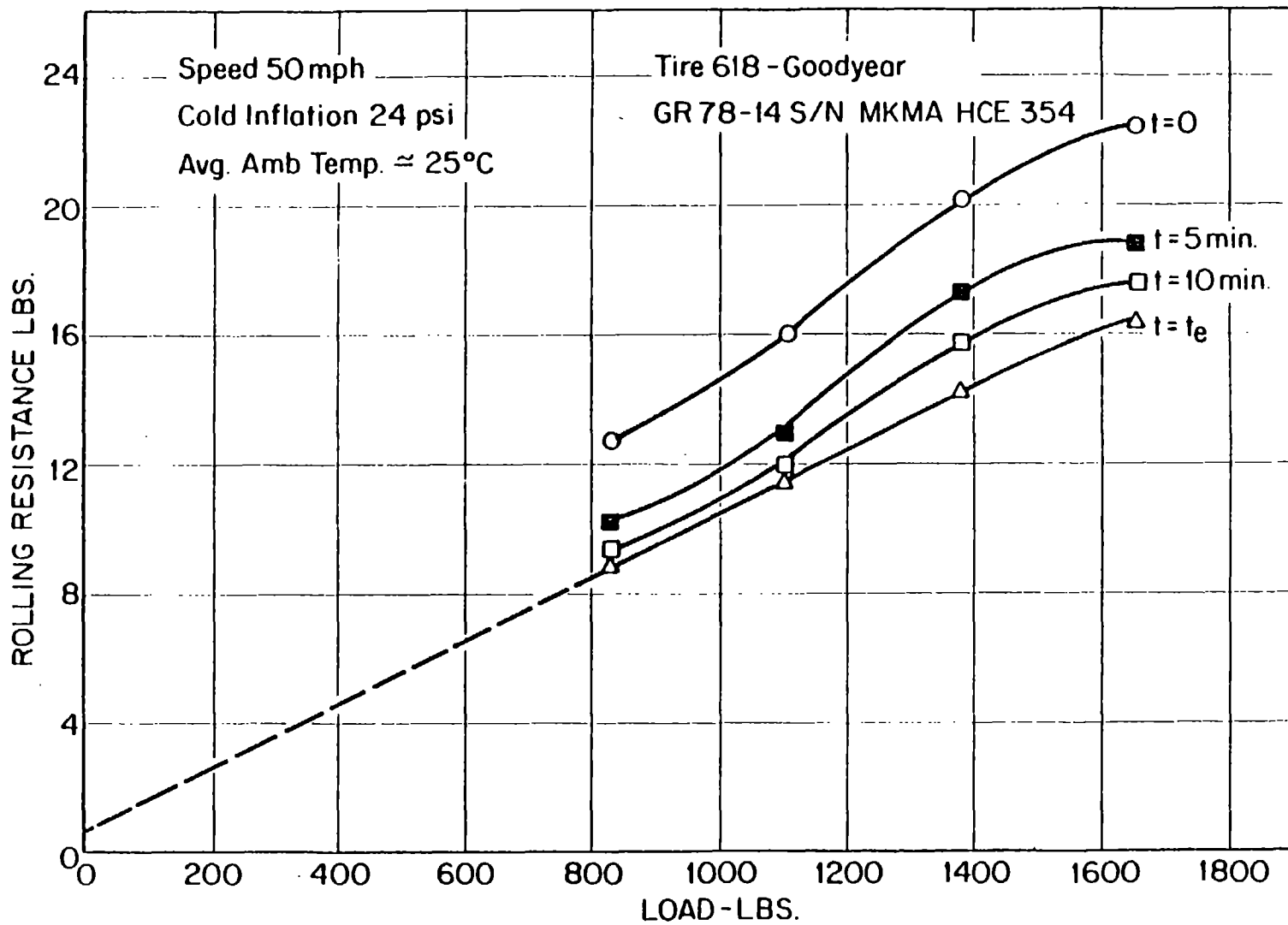

FIGURE 6. ROLLING RESISTANCE VS. VERTICAL LOAD FOR GR78-14 RADIAL TIRE

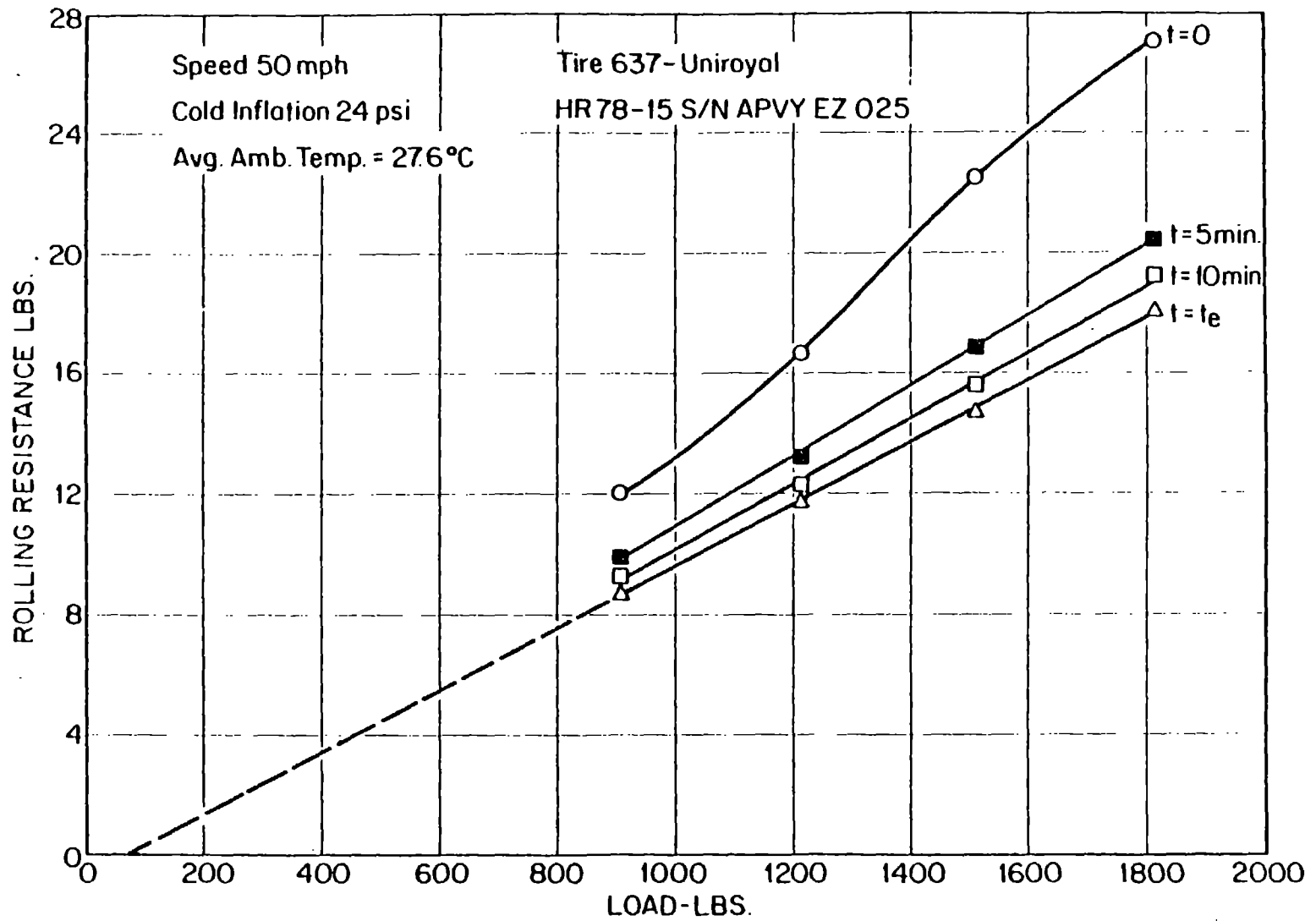

FIGURE 7. ROLLING RESISTANCE VS. VERTICAL LOAD FOR HR78-15 RADIAL TIRE

lengths probably is most important in the first 15 minutes of the trip. This is an important segment of the many short trips which occur so frequently.

The linear nature of the equilibrium rolling resistance as a function of load is apparently fortuitous, but is well known and has led to the common and very useful concept of the coefficient of rolling resistance, which is defined as the rolling resistance divided by the load carried. Using the data of Figures 4 - 7, the coefficient of rolling resistance may be replotted as a function of load and time and is shown in Figures 8 - 11 for the same four tires.

The coefficient of rolling resistance is a convenient concept since it allows one to compare various tires for use on the same vehicle. The load carried by a tire will be the same on a given vehicle in a given tire position, so a comparison of the rolling resistance coefficients will show which tire is the most efficient for a given application. On the other hand, tests of tire rolling resistance are usually carried out at the tire rated load or at some relatively large fraction of it, such as 80% of tire rated load. Direct presentation of the rolling resistance under these conditions is dependent on the load carried by the tire, which, of course, varies for different tire sizes. Hence, the concept of the coefficient is a generalizing and extremely useful one for both the presentation and interpretation of data.

Figures 8 - 11 show that for the two bias and two radial tires described there, the coefficient of rolling resistance increases with increasing load for the cold, or initial, state. For the equilibrium state the coefficients of rolling resistance are, on the average, essentially independent of load.

Examination of data taken at fixed tire load and variable initial inflation pressure shows that the tire rolling resistance decreases as the inflation pressure is increased. This is caused primarily by the reduced deflection of the tire when running under a higher inflation pressure as compared with lower. The effect with pressure is not a linear one, since as inflation pressure is decreased the tire rolling resistance increases markedly. However, it has been shown in the past, and present data collected for this handbook substantiate this conclusion, the rolling resistance is nearly linear with the reciprocal of initial inflation pressure under conditions of capped air, steady state running and constant load. The four tires discussed in Figures 4 - 11 were tested under a variety of initial inflation pressures and the resulting rolling resistance values are plotted as a function of the reciprocal of inflation pressure in Figures 12 - 15, again for various times so that the influent of running time may be illustrated.

From this data it is seen that the simplest and most consistent relationship is a linear one with the reciprocal pressure for equilibrium running conditions. All four tires exhibit this, and this phenomenon has also been reported elsewhere [1]. It should be noted that the curves do not intersect the zero rolling resistance point as the reciprocal of pressure approaches zero, which implies that at very large inflation pressures some rolling loss would still remain in the tire.

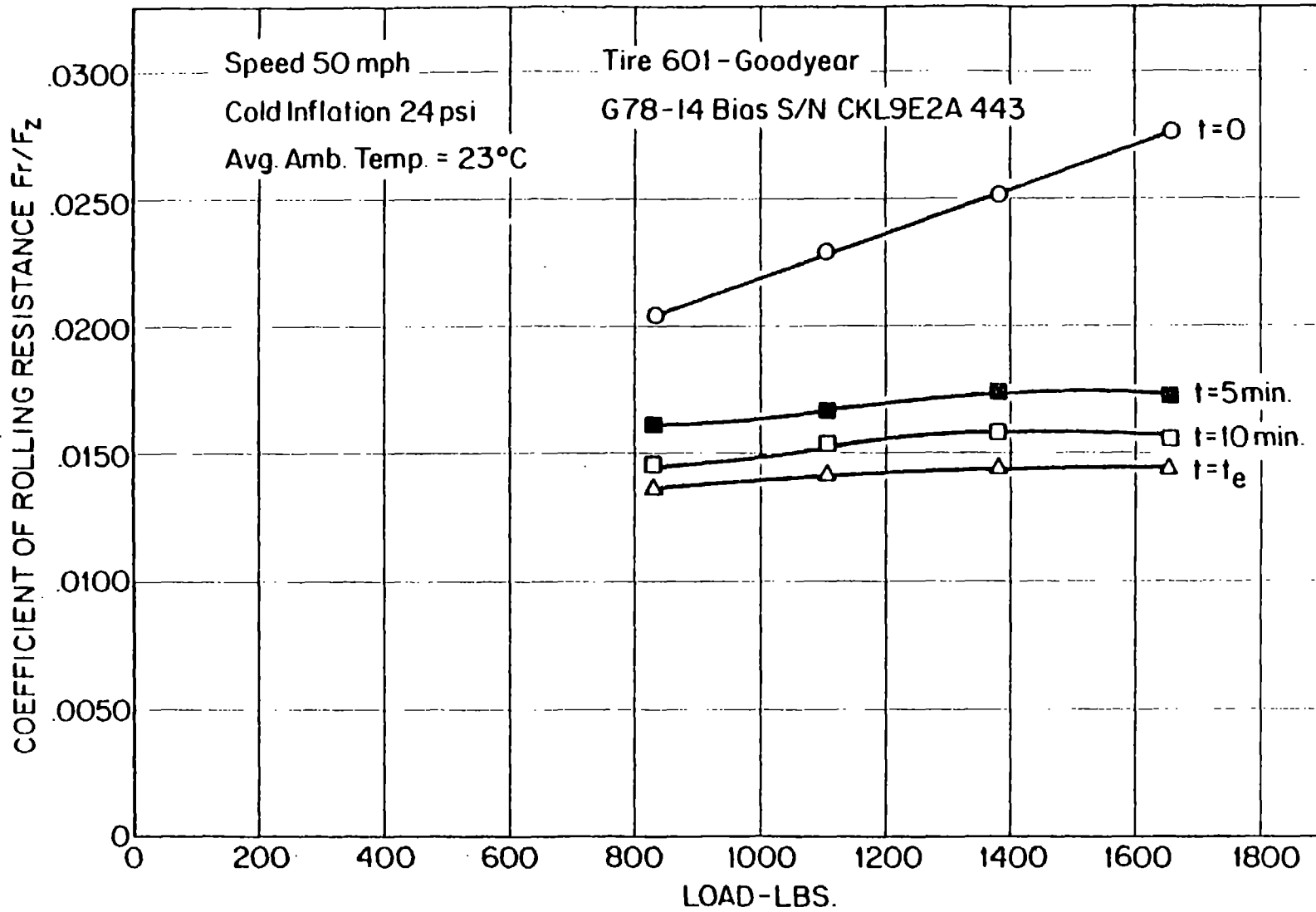

FIGURE 8. COEFFICIENT OF ROLLING RESISTANCE VS. VERTICAL LOAD FOR G78-14 BIAS TIRE

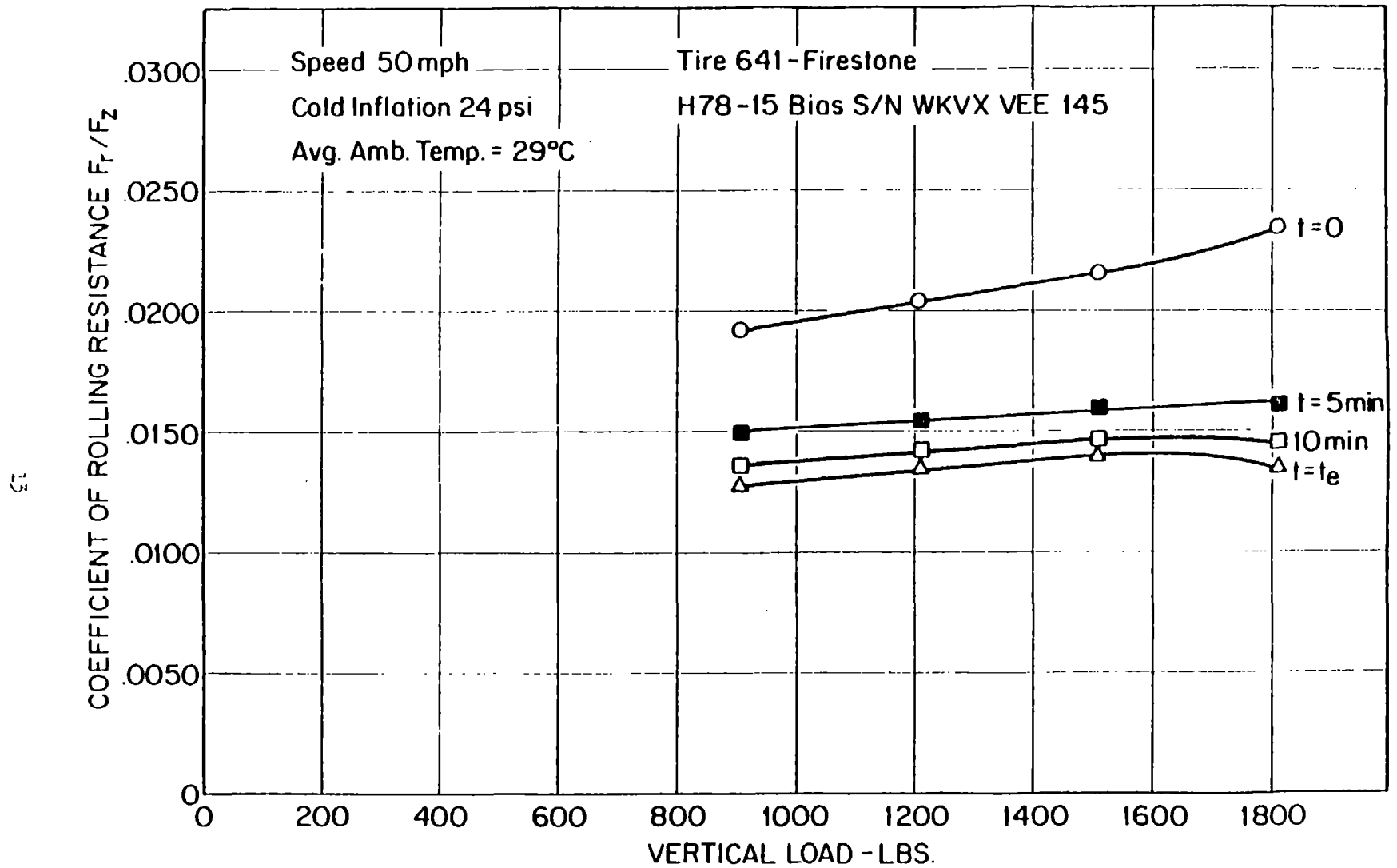

FIGURE 9. COEFFICIENT OF ROLLING RESISTANCE VS. VERTICAL LOAD FOR H78-15 BIAS TIRE

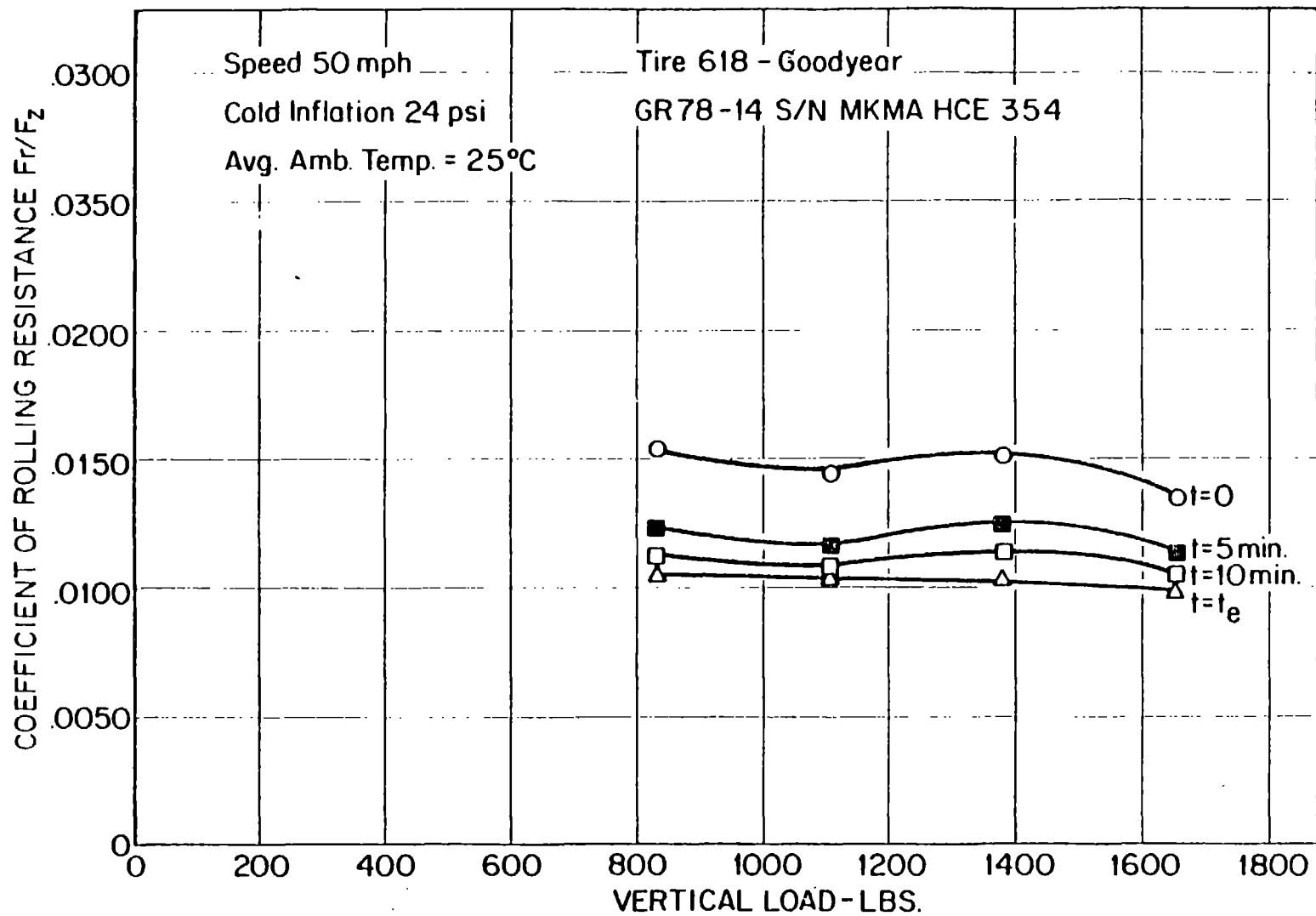

FIGURE 10. COEFFICIENT OF ROLLING RESISTANCE VS. VERTICAL LOAD
FOR GR78-14 RADIAL TIRE

51

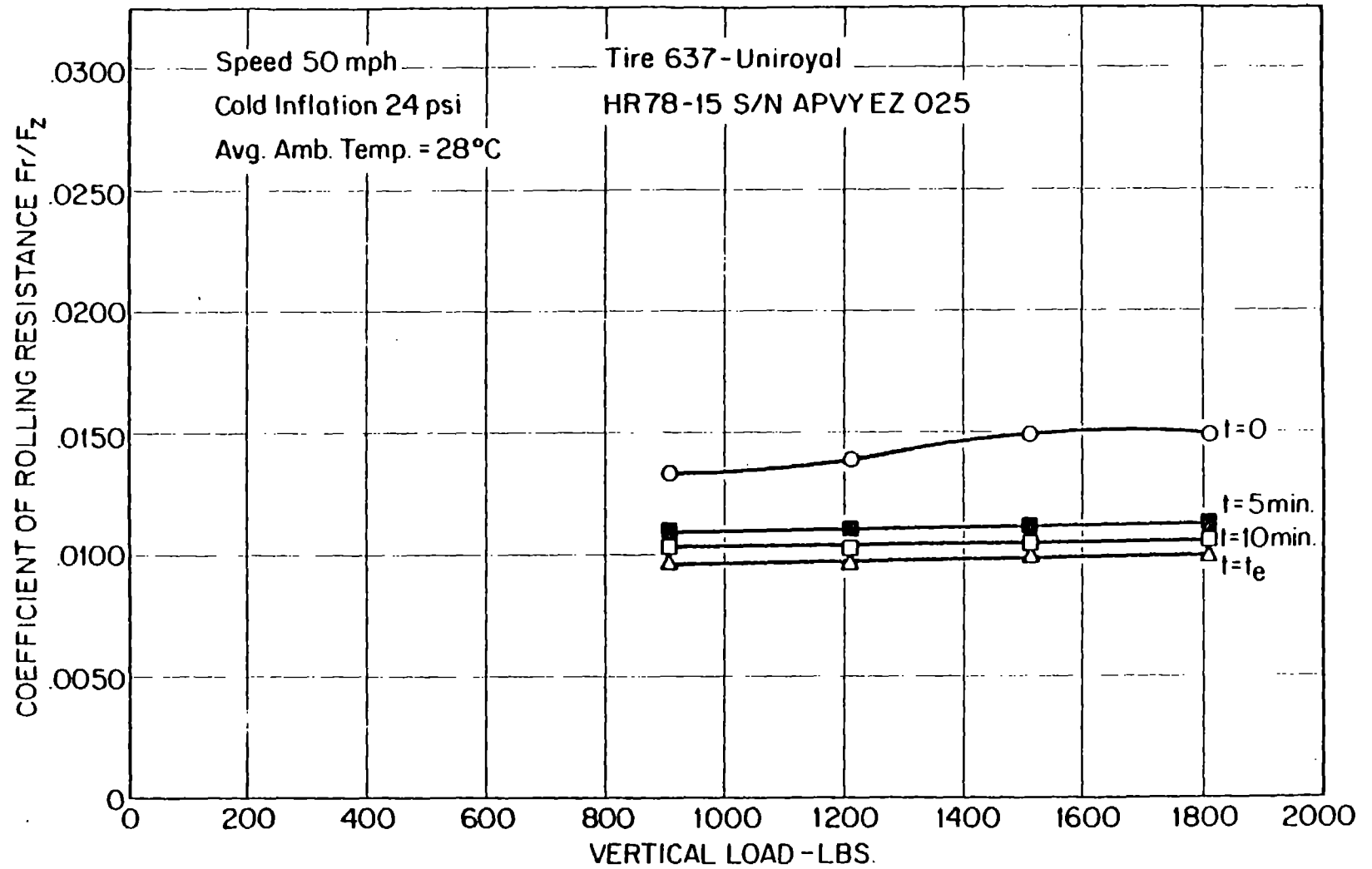

FIGURE 11. COEFFICIENT OF ROLLING RESISTANCE VS. VERTICAL LOAD FOR HR78-15 RADIAL TIRE

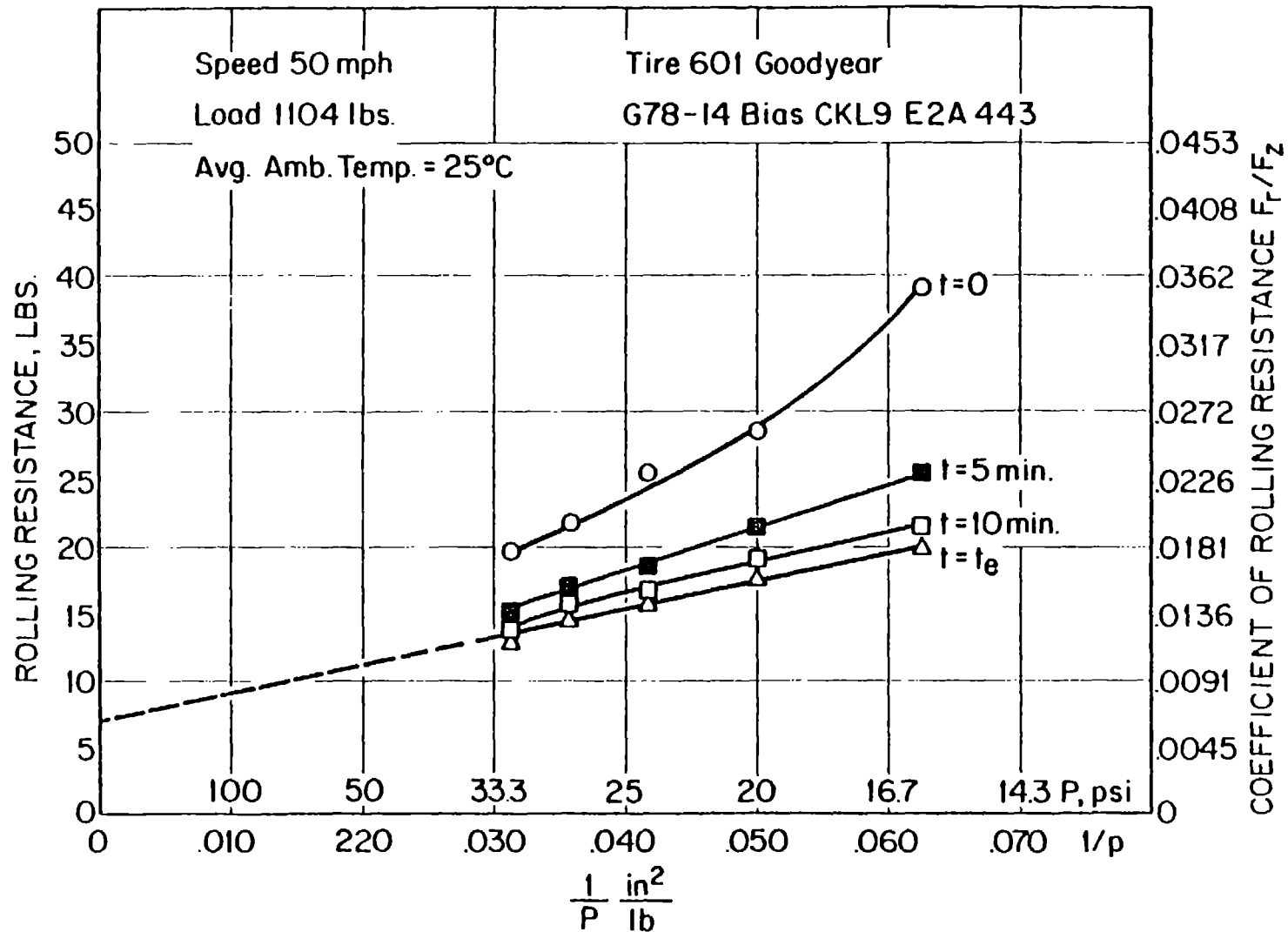

FIGURE 12. ROLLING RESISTANCE AND COEFFICIENT OF ROLLING RESISTANCE VS. RECIPROCAL OF INFLATION PRESSURE FOR G78-14 BIAS TIRE

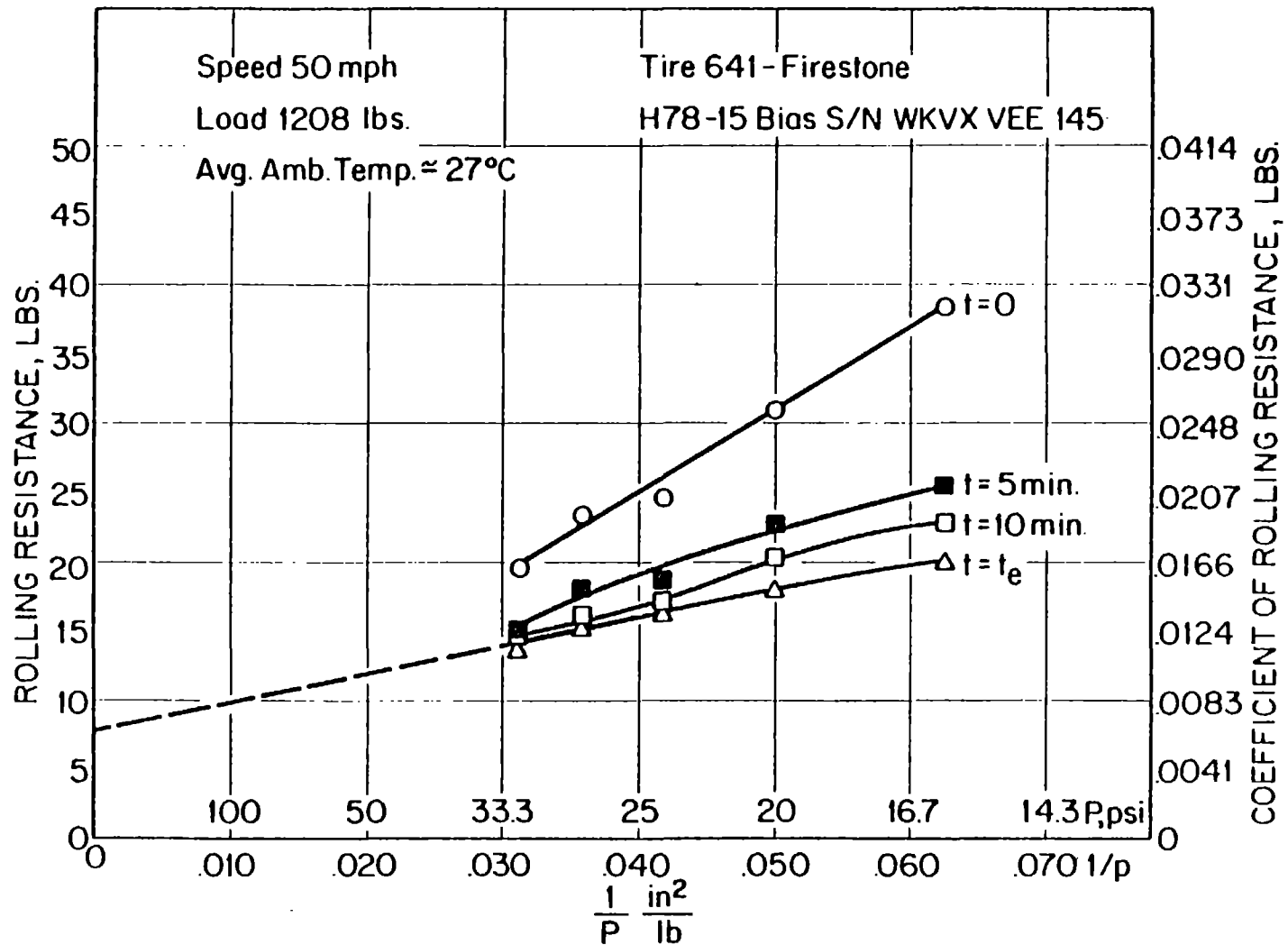

FIGURE 13. ROLLING RESISTANCE AND COEFFICIENT OF ROLLING RESISTANCE VS. RECIPROCAL OF INFLATION PRESSURE FOR H78-15 BIAS TIRE

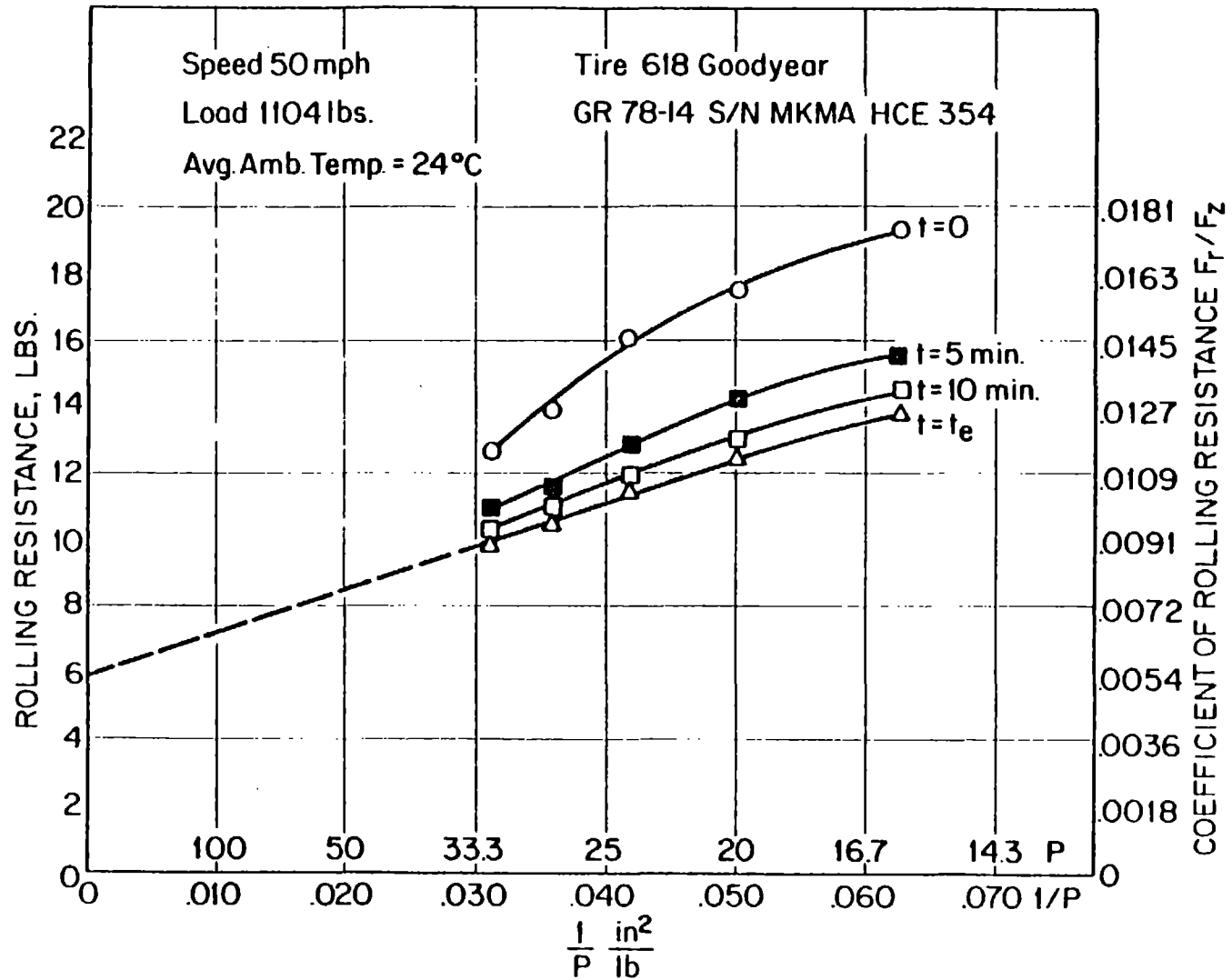

FIGURE 14. ROLLING RESISTANCE AND COEFFICIENT OF ROLLING RESISTANCE VS. RECIPROCAL OF INFLATION PRESSURE FOR GR78-14 RADIAL TIRE

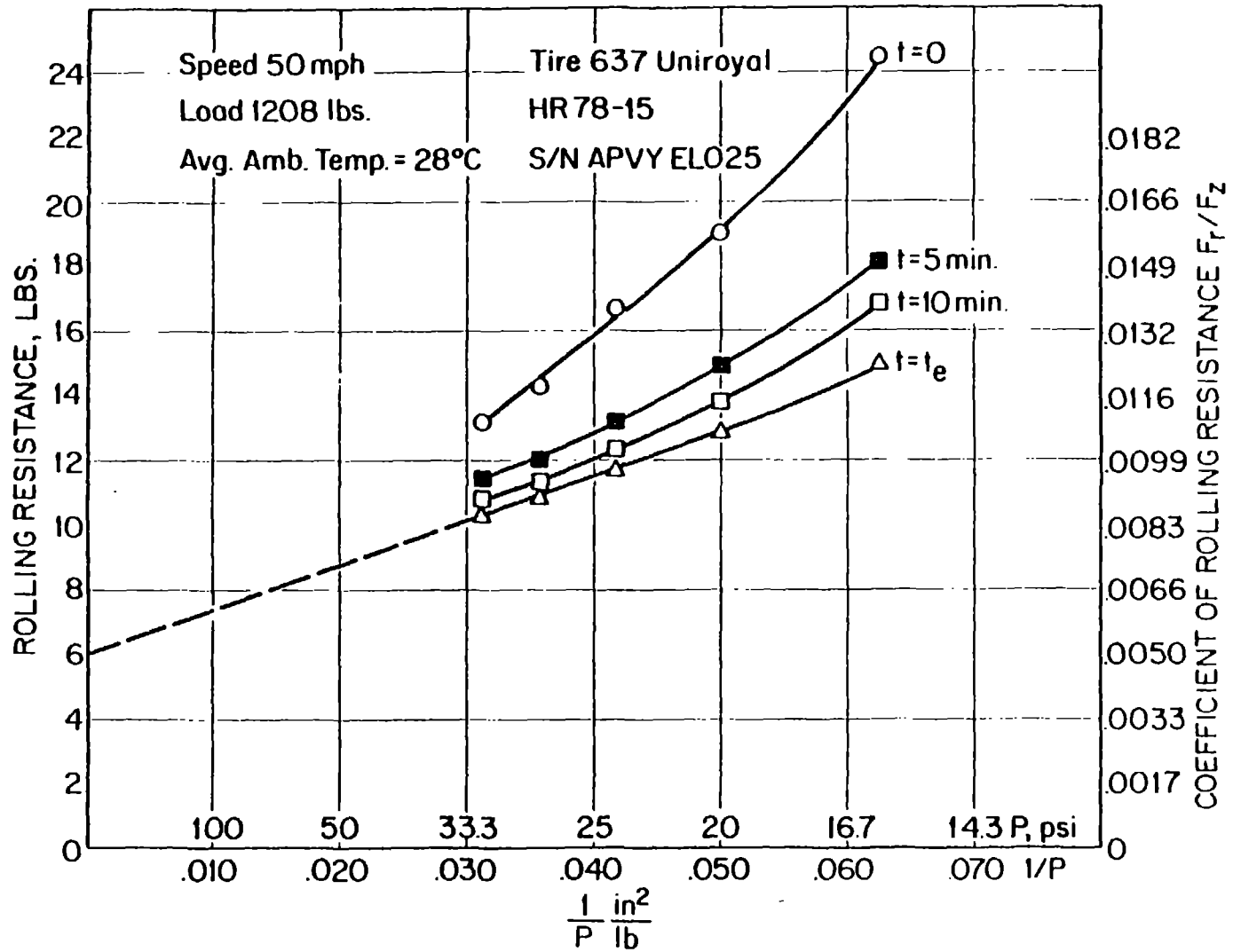

FIGURE 15. ROLLING RESISTANCE AND COEFFICIENT OF ROLLING RESISTANCE VS. RECIPROCAL OF INFLATION PRESSURE FOR HR78-15 RADIAL TIRE

Figures 8 - 11 and 12 - 15 now suggest that the relationship between equilibrium rolling resistance, load on the tire and initial inflation pressure may be expressed in the form of Eq. (1).

$$F_r \sim F_z \left(\frac{c_p}{p} + c_r \right) \quad (1)$$

where

F_r = tire rolling resistance at equilibrium conditions

F_z = load on tire

p = initial inflation pressure

c_p, c_r = constants

A more thorough exposition of this concept will be made in Section IV of this handbook.

Examination of the same figures also shows that no comparably simple relationship exists for the relation between load and pressure and initial or cold tire rolling resistance. The resistance is not linear with load nor with the reciprocal of pressure, and no generalized relation such as that of Eq. (1) has yet been proposed.

The question of speed effect on rolling resistance has been one of considerable uncertainty in the earlier published literature. Some measurements have been reported showing rather marked effects of speed on rolling resistance, while other measurements show very little effect. A recent series of measurements on a single set of tires carried out by a number of the major American tire manufacturers showed that the rolling resistance of the sample tires was nearly independent of speed within the speed ranges normally encountered on the American highways today [4]. Figure 16 shows the mean value of rolling resistance for five different common American passenger car tires at three different speeds as measured over nine different laboratories ranging from a 64-inch diameter cylindrical drum to a flat surface. These measurements were carried out at 30, 50, and 70 mph, and show that the rolling resistance is nearly constant with speed up to 50 mph, while at 70 mph the general tendency is for a small increase. It is surmised that the effects here are combinations of higher temperature and greater pressure buildup associated with higher running speeds, while at the same time greater dynamic effects are also associated with these higher speeds. The two influences are counteracting, and probably tend to cause the relatively uniform response with speed as illustrated in Figure 16.

The question of size and construction is an important one in assessing the rolling resistance of a tire. For purposes of this study a wide variety of

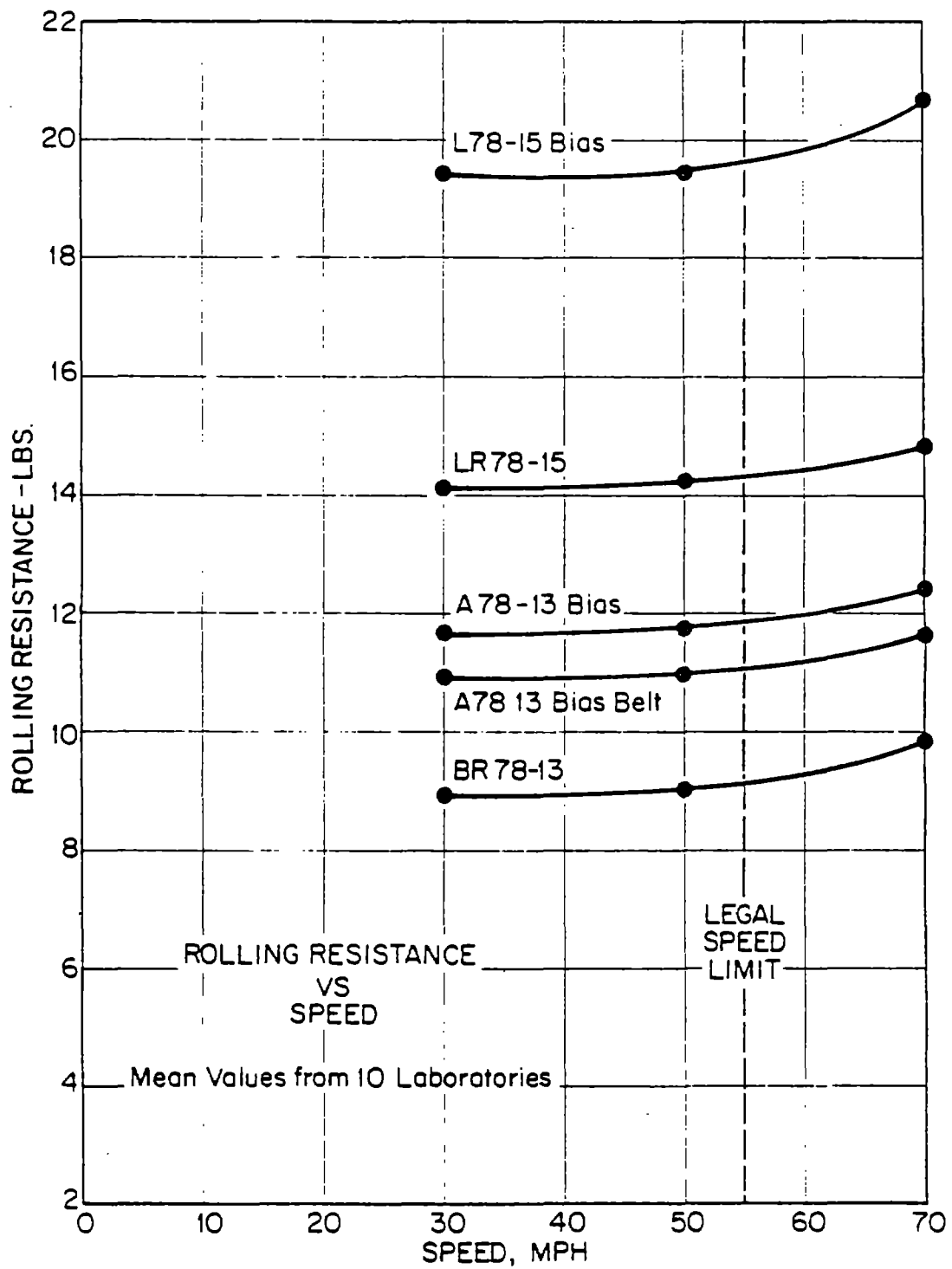

FIGURE 16. ROLLING RESISTANCE VS. SPEED FOR A GROUP OF MODERN PASSENGER CAR TIRES

passenger car tires were tested for their rolling resistance characteristics. These tests numbered some 65 different tires encompassing most of the common construction and manufacturers. The results of these tests are expressed as the absolute value of rolling resistance at 80% of the rated load of each of the tires, and are plotted in Figure 17 as a function of the tire load rating, with the increasing load ratings being plotted to the right of the figure. (Individual test results are given in Table I.) On this curve each measured rolling resistance is plotted as a single point showing the rolling resistance value obtained at equilibrium conditions and at a speed of 50 mph using 24 psi initial inflation pressure and capped air conditions. The rolling resistance values are generally seen to increase as the tires become bigger in size, but of course the load carried by them also increases. From the data plotted it is seen that radial tires are more efficient than similarly sized bias and bias-belted tires. It is also seen that where more than one tire of a given construction was tested, considerable spread can be observed in the data. This implies that there are differences between the rolling resistance of the same size tires from different manufacturers, as well as differences between rolling resistance of the same size tires from the same manufacturer. The exact quantitative value of such spread is a matter for further investigation.

Most of the major American tire manufacturers now have development programs for so-called "fuel efficient" tires, that is, tires with markedly reduced rolling resistance but with acceptable levels of performance in other areas. Three of these tires were also tested for this program of measurement, and the resulting rolling resistance values are also plotted in Figures 17 and 18 using a special symbol for the data point. While these tires are designed to operate normally at either 26 or 35 psi inflation pressure, we have adjusted the tire rolling resistance to a value of 24 psi in order to make the data consistent with the other measurements given in those figures. When this is done it is clear that these tires do not exhibit much improvement over existing commercial radial tires. Their advantage seems to be that they can be operated at higher pressures, such as 26 or 35 psi, in which case they are more fuel efficient than existing lower-pressure radial tires.

This same data may be presented in a somewhat different fashion by plotting the coefficient of rolling resistance of the tires discussed in Figure 17, again as a function of tire load rating. This is shown in Figure 18. From this it may be seen that for a given vehicle the most efficient tires in terms of rolling resistance are the larger sizes, since their coefficients of rolling resistance are slightly less than those of the smaller sizes. Again the radial tires are definitely more efficient than bias and bias-belted tires, and are to be preferred where available.

The role of aspect ratio is not clear in Figure 18. On the whole there may be some tendency for low aspect ratio tires to exhibit slightly reduced rolling resistance coefficients as compared with higher aspect ratio tires. This would be expected from physical considerations. The effect is small in this data and the benefits, if they exist, are not very striking.

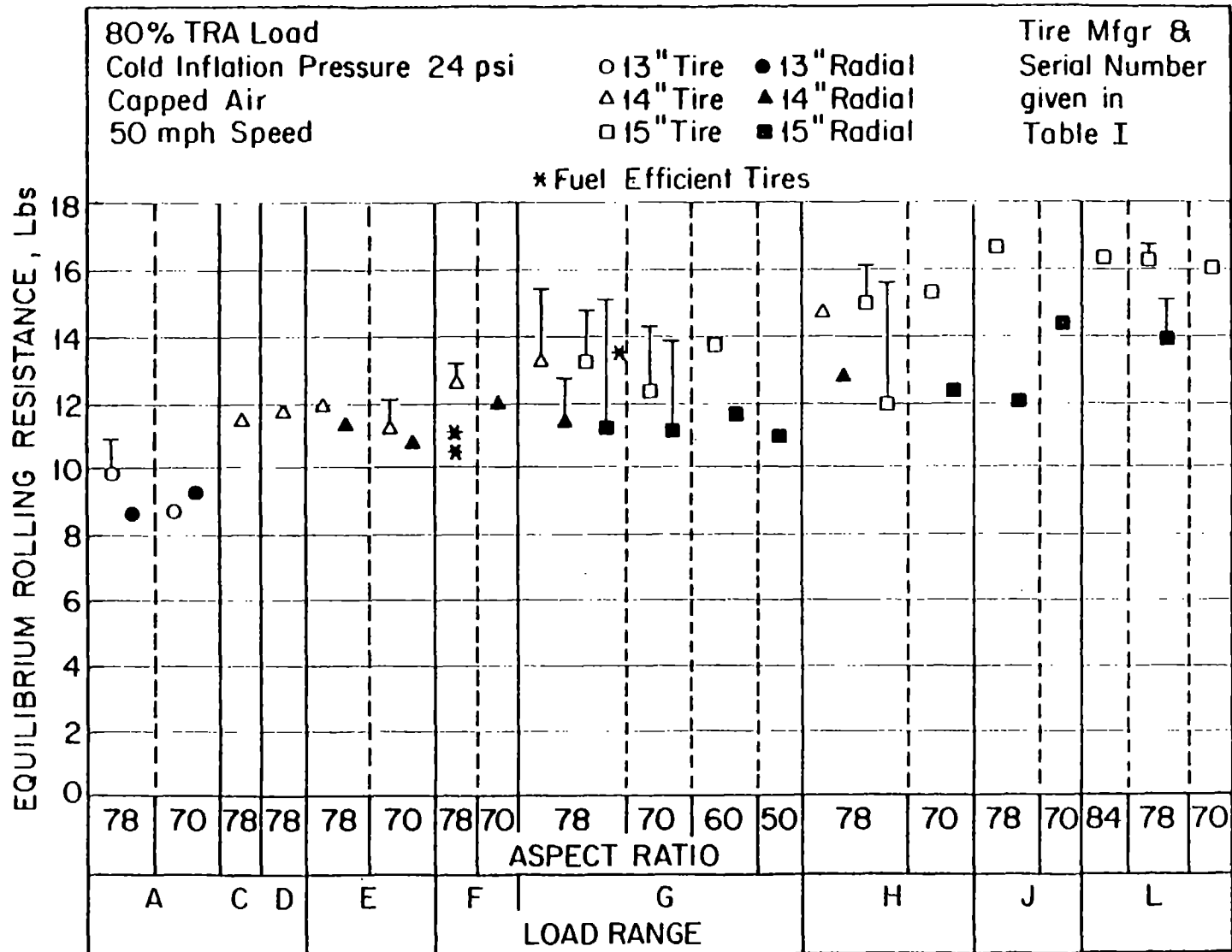

FIGURE 17. ROLLING RESISTANCE VS. TIRE LOAD RATING FOR A TYPICAL SELECTION OF PASSENGER CAR TIRES

TABLE I.-TIRE IDENTIFICATION AND TEST DATA

Tire Number	Tire Description	Construction	Manufacturer	Serial Number	Vertical Load, lb	Initial Inflation Pressure, psi	Equilibrium Inflation Pressure, psi	Initial Cavity Temperature, °C	Equilibrium Cavity Temperature, °C	Initial Rolling Resistance, lb	Equilibrium Rolling Resistance, lb
1	G78-14 B	4P	Goodyear	CKL9 E2A 443	878	24	27.8	21	48	16.91	11.52
2	G78-14 B	4P	Goodyear	CKL9 E2A 443	1104	24	29.0	19	58	25.46	15.70
3	G78-14 B	4P	Goodyear	CKL9 E2A 443	1380	24	31.0	22	69	34.72	19.93
4	G78-14 B	4P	Goodyear	CKL9 E2A 443	1656	24	33.0	21	81	45.90	23.70
5	G78-14 B	4P	Goodyear	CKL9 E2A 443	1104	16	21.4	23	70	39.21	19.61
6	G78-14 B	4P	Goodyear	CKL9 E2A 443	1104	20	25.3	23	69	28.48	17.12
7	G78-14 B	4P	Goodyear	CKL9 E2A 443	1104	28	32.5	25	59	21.74	14.45
8	G78-14 B	4P	Goodyear	CKL9 E2A 443	1104	32	37.0	25	56	19.71	13.23
9	H78-15 B	4P	Firestone	WKVX VEE 145	906	24	27.3	28	48	17.40	11.55
10	H78-15 B	4P	Firestone	WKVX VEE 145	1208	24	28.5	26	57	24.59	16.19
11	H78-15 B	4P	Firestone	WKVX VEE 145	1510	24	30.0	27	66	32.69	21.39
12	H78-15 B	4P	Firestone	WKVX VEE 145	1812	24	32.0	28	79	42.29	25.19
13	H78-15 B	4P	Firestone	WKVX VEE 145	1208	16	22.2	25	69	38.39	19.79
14	H78-15 B	4P	Firestone	WKVX VEE 145	1208	20	24.6	24	65	30.90	17.99
15	H78-15 B	4P	Firestone	WKVX VEE 145	1208	28	31.8	26	53	23.39	15.30
16	H78-15 B	4P	Firestone	WKVX VEE 145	1208	32	35.8	25	50	19.49	14.10
17	GR78-14 R	2P+2S/2P	Goodyear	MKMA ICE 354	828	24	26.4	25	41	12.72	8.79
18	GR78-14 R	2P+2S/2P	Goodyear	MKMA ICE 354	1104	24	27.0	24	44	16.06	11.51
19	GR78-14 R	2P+2S/2P	Goodyear	MKMA ICE 354	1380	24	28.5	21	50	20.90	14.24
20	GR78-14 R	2P+2S/2P	Goodyear	MKMA ICE 354	1656	24	29.0	22	57	22.42	16.35
21	GR78-14 R	2P+2S/2P	Goodyear	MKMA ICE 354	1104	16	19.8	19	56	19.39	13.78
22	GR78-14 R	2P+2S/2P	Goodyear	MKMA ICE 354	1104	20	25.0	21	49	17.57	12.42
23	GR78-14 R	2P+2S/2P	Goodyear	MKMA ICE 354	1104	28	30.8	22	45	15.94	10.45
24	GR78-14 R	2P+2S/2P	Goodyear	MKMA ICE 354	1104	32	35.0	23	44	12.72	9.84
25	HR78-15 R	4P+2S/2H	Uniroyal	APVY EL 025	906	24	27.6	25	44	12.04	8.72
26	HR78-15 R	4P+2S/2H	Uniroyal	APVY EL 025	1208	24	29.0	24	51	16.70	11.73
27	HR78-15 R	4P+2S/2H	Uniroyal	APVY EL 025	1510	24	30.3	25	60	22.57	14.74
28	HR78-15 R	4P+2S/2H	Uniroyal	APVY EL 025	1812	24	31.5	29	67	27.08	18.05
29	HR78-15 R	4P+2S/2H	Uniroyal	APVY EL 025	1208	16	20.0	26	63	24.39	15.04
30	HR78-15 R	4P+2S/2H	Uniroyal	APVY EL 025	1208	20	24.9	27	57	18.96	12.78
31	HR78-15 R	4P+2S/2H	Uniroyal	APVY EL 025	1208	28	32.9	27	50	14.29	10.84
32	HR78-15 R	4P+2S/2H	Uniroyal	APVY EL 025	1208	32	36.5	25	48	13.24	10.23

Reproduced from
best available copy.



TABLE I. - CONTINUED

Tire Number	Tire Description	Construction	Manufacturer	Serial Number	Vertical Load, lb	Initial Inflation Pressure, psi	Equilibrium Inflation Pressure, psi	Initial Cavity Temperature, °C	Equilibrium Cavity Temperature, °C	Initial Rolling Resistance, lb	Equilibrium Rolling Resistance, lb
44	SR0-15 R	—	—	—	1104	24	28.6	23	52	15.55	15.98
45	SR0-15 R	4P	General	VTVF WGM 493	1104	24	26.5	25	57	17.75	15.80
46	SR0-15 R	—	B. F. Goodrich	BEUF LE2 416	1104	24	26.8	23	50	16.33	11.65
47	SR0-15 R	4P	Lee	JCUV IAF 344	1104	24	27.5	27	57	21.75	14.20
48	SR0-15 R	2P+2S/2P	Goodyear	MJUS CXI 454	1104	24	26.5	24	44	14.64	11.16
49	A70-14 B	4P	Goodyear	MJFS K2A 034	720	24	27.7	25	52	15.70	9.86
50	F70-14 B	4P	Lee	JCLB IAF 145	952	24	—	27	51	18.25	12.18
51	H70-15 B	4P	Lee	JCU6 IAF 334	1208	24	27.6	23	56	21.55	15.94
52	A78-13 B	4P	Dunlop	DAFS C47 104	720	24	—	25	61	17.70	10.78
53	F78-14 B	4P	Dunlop	DBL7 C47 234	1024	24	27.5	26	54	19.55	12.73
54	G78-14 B	4P	Dunlop	DBL9 C47 204	1104	24	27.7	25	56	20.56	13.90
55	G78-15 B	4P	Dunlop	DBV7 C47 194	1104	24	28.6	23	53	19.89	13.36
56	H78-15 B	4P	Dunlop	DBVX C47 462	1208	24	28.2	21	53	22.52	15.01
57	A70-15 BB	2P+2F/2P	Goodyear	MJF4 Y4A 244	720	24	—	27	48	12.82	8.80
58	F70-14 BB	2P+2F/2P	Goodyear	MDLB Y4A 343	952	24	27.5	23	52	17.40	11.29
59	G70-15 BB	2P+2F/2P	Goodyear	MJUH YYA 163	1104	24	28.8	23	48	18.74	12.40
60	A78-15 BB	2P+2F/2P	Goodyear	MHF5 P5A 393	720	24	28.3	24	58	16.01	9.85
61	C78-14 BB	2P+2F/2P	Goodyear	MNL1 DDA 134	840	24	28.0	26	53	17.70	11.44
62	D78-14 BB	2P+2F/2P	Goodyear	MPL3 DDA 244	896	24	27.0	23	51	17.52	11.73
63	F78-14 BB	2P+2F/2P	Dunlop	DBL5 C42 204	952	24	28.0	24	51	17.93	11.85
64	H78-14 BB	2P+2F/2P	Goodyear	MHMB DDM 154	1208	24	28.8	20	54	22.48	14.75
65	F78-14 BB	2P+2F/2P	Goodyear	CDWF R8DF	1024	24	27.8	21	50	21.15	13.14
66	G78-15 BF	2P+2F/2P	Goodyear	MMV4 DDA 154	1104	24	28.8	21	53	22.59	14.61
67	H78-15 BB	2P+2F/2P	Goodyear	MKUX DDH 124	1208	24	28.2	23	53	22.37	15.01
68	A78-15 BB	2P+2F/2P	Goodyear	MKV1 DDH 114	1264	24	26.2	19	58	25.38	16.63
69	L78-15 BB	2P+2F/2P	Goodyear	MEU3 PKH 244	1340	24	29.0	19	56	25.72	16.90
70	184-15 BB	2P+2F/2P	Goodyear	MEWA DDIH 234	1340	24	28.3	25	54	25.96	16.41
71	G78-15 BE	2P+2S/2P	Goodyear	MKVV E9H 443	1104	24	28.0	23	57	22.30	14.77
72	L78-15 BB	2P+2S/2P	Goodyear	MKY5 E9H 493	1340	24	27.0	23	57	27.51	16.74
73	155 SR-13 R	2P+2S/2P	Goodyear	NBF5 AC2 373	648	24	26.0	25	44	11.81	8.99
74	165 SR-13 R	2P+2S/2P	Goodyear	NBE9 AC2 493	688	24	27.0	23	47	14.51	9.62
75	165 SR-14 R	1P+2S/2P	Goodyear	NBJ1 NN2 373	768	24	27.0	23	43	13.20	9.37

TABLE I.-CONCLUDED

Tire Number	Tire Description	Construction	Manufacturer	Serial Number	Vertical Load, lb	Initial Inflation Pressure, psi	Equilibrium Inflation Pressure, psi	Initial Cavity Temperature, °C	Equilibrium Cavity Temperature, °C	Initial Rolling Resistance, lb	Equilibrium Rolling Resistance, lb
73	155 SR-15 R	2P+2S/2P	Goodyear	NK37 AC2 974	692	24	28.0	25	44	11.64	8.58
74	165 SR 15 R	2P+2S/2P	Goodyear	NCTB AC2 593	768	24	26.3	23	44	14.49	9.77
75	AR70-13 R	2P+4R+1S/2P	Goodyear	MROJ JKT 174	720	24	26.5	25	48	13.91	9.28
76	ER70-14 R	2P+4R+1S/2P	Goodyear	MJLC JKT 684	952	24	26.8	22	49	16.92	10.85
77	FR70-14 R	—	—	—	1024	24	28.2	25	51	19.50	12.00
78	IR70-15 R	6R+1S/2R	Daytona	HY05 HNY 513	1104	24	28.0	21	56	24.00	15.87
79	UR70-15 R	2P+2S+1N/2P	Goodyear	MK07 FWL 314	1208	24	27.0	19	44	18.02	12.52
80	UR70-15 R	6R+1S/2R	Daytona	HY09 HNY 154	1264	24	27.0	20	54	21.74	14.35
81	LR70-15 R	6R+1S/2R	Daytona	HY00 HNY 523	1340	24	27.8	23	60	28.64	16.11
82	GR70-15 R	2P+2S/2P	Firestone	—	1104	24	27.0	23	58	22.94	15.74
83	AR78-13 R	2P+2S/2P	Cooper	UPKK NDN 404	720	24	28.0	19	48	12.05	8.64
84	ER78-14 R	2P+2S/2P	Goodyear	MKMC AYH 234	1208	24	27.8	25	48	18.24	12.66
85	ER78-14 R	2P+2S/2P	Cooper	UT16 HDY 115	952	24	28.5	—	—	16.76	11.27
86	GR78-14 R	2P+2S/2P	Cooper	UTMA HDV 115	1104	24	27.5	24	57	17.88	12.72
87	UR78-14 R	2P+2S/2P	Cooper	UTMC HDW 115	1208	24	27.8	24	57	18.71	12.82
88	GR78-15 R	2P+2S/2P	Cooper	UTW FBN 115	1104	24	28.0	25	53	16.44	11.77
89	UR78-15 R	2P+2S/2P	Cooper	UTVY HBP 154	1208	24	28.0	23	54	17.29	12.18
90	IR78-15 R	2P+2S+1N/2P	Goodyear	ME02 FNE 084	1264	24	26.8	23	47	17.08	11.99
91	LR78-15 R	2P+2S/2P	Cooper	UTVY HDY 234	1340	24	28.5	22	57	20.65	13.92
92	GR78-15 R	6R/2R	Firestone	VEVW XVD 254	1104	24	27.8	25	61	21.42	15.08
93	LR78-15 R	6R/2R	Firestone	VEVY XVD 254	1208	24	27.5	25	62	22.55	15.64
94	LR78-15 R	—	B. F. Goodrich	BEV4 P71225	1340	24	27.2	24	52	21.24	15.11
95	GR78-15 R	2P+2S/2P	B. F. Goodrich	BEVW DR 1504	1104	24	27.5	23	50	15.26	10.12
96	GR78-15 R	—	—	—	1104	24	27.0	25	50	16.50	11.16
97	165 HR-15 R	2R+2S/2R	Michelin	IGM 5392 R/h4	688	24	26.8	26	46	12.35	7.42
98	165 HR-13 R	2R+2S/2R	Michelin	—	688	24	25.5	26	45	10.43	7.24
99	A78-13 33	—	Goodyear	—	720	24	—	24	51	16.93	10.97
101	F78-14 5	4P	Dunlop	DBL7 C47 234	840	24	27.0	25	48	15.96	9.55
102	G78-14 8	4P	Dunlop	DBL9 C47 204	780	24	26.5	26	46	12.40	8.52
103	E78-14 9B	2P+2P/2P	Dunlop	DBL5 C42 204	840	24	27.5	24	51	14.59	10.05
104	IR78-14 8B	2P+2P/2P	Goodyear	MDMB DDW 154	840	24	26.5	26	44	13.55	9.65
105	LR78-15 R	2P+2S/2P	B. F. Goodrich	—	1104	24	26.8	24	48	16.60	11.97
106	GR78-15 R	2P+2S/2P	B. F. Goodrich*	BEVW DR 1504	1104	24	—	25	57	22.35	15.58
107	165 HR-15 R	2R+2S/2R	Michelin*	IGM 5392 R/h4	688	24	—	24	49	13.69	8.92
108	P215 / 65R 390	—	Goodyear	TX 8303-13	1065	26	—	—	—	—	10.64
109	P185 / 80R 13	—	Uniroyal	AJ-22-3118	1041	26	—	—	—	—	10.22
110	P195 / 75R 14	—	Firestone	R 719	1120	26	—	—	—	—	13.62

*Retreaded.

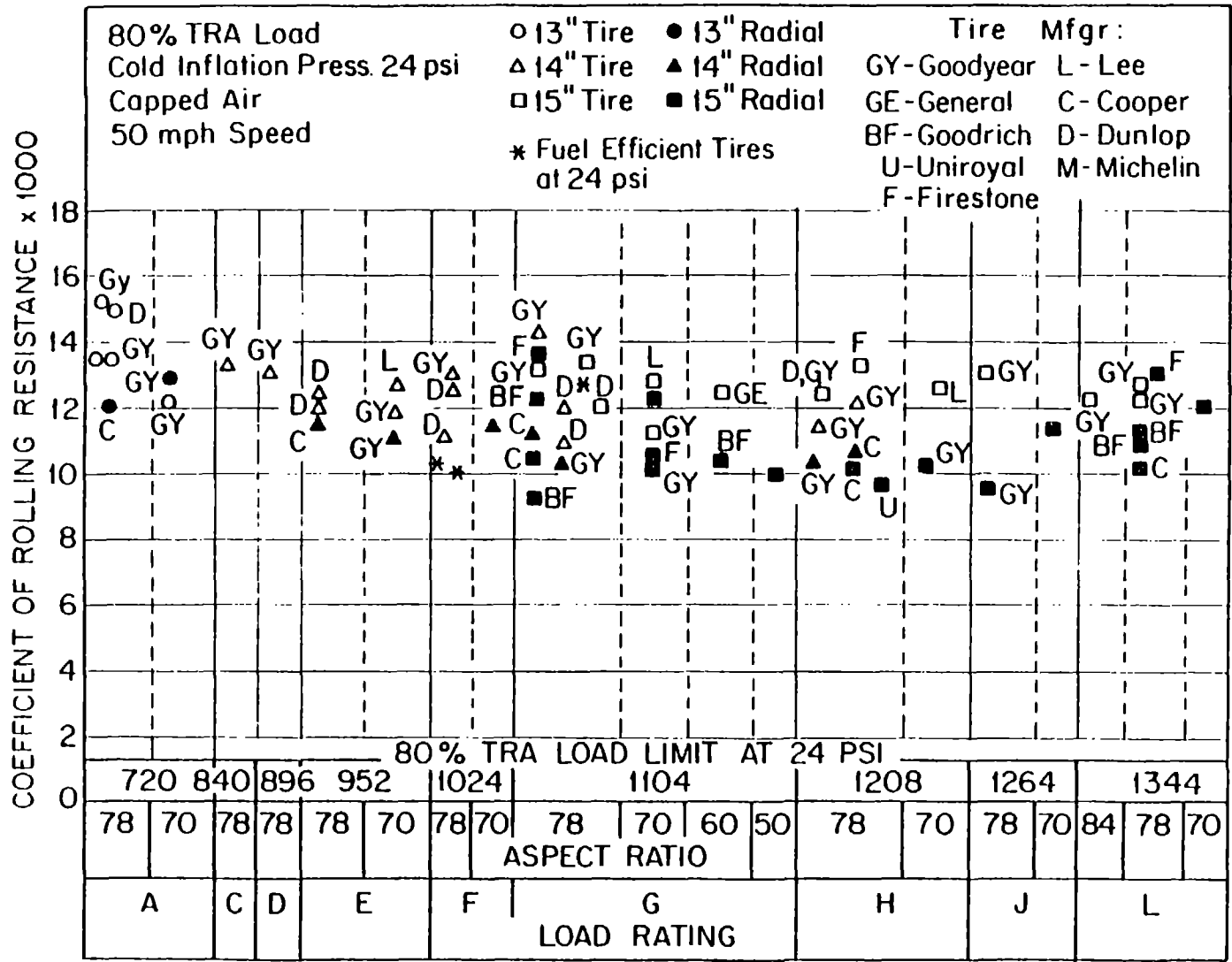

FIGURE 18. COEFFICIENT OF ROLLING RESISTANCE VS. TIRE LOAD RATING FOR A SELECTION OF PASSENGER CAR TIRES

In view of the rapidly increasing numbers of light trucks and vans in the American vehicle fleet, the rolling resistance characteristics of light truck tires is an important factor in vehicle fuel simulation. For that reason a group of four common sizes of light truck tires were chosen and rolling resistance measurements carried out on them. Since they are considerably larger and operate at higher pressures and loads than passenger car tires, the results of these measurements are presented in Tables II through VI.

TABLE II.-TEST DATA FOR 7.00-15 LT TIRE

Dia. = 29.6 in.

Tire Load, lb	Inflation Pressure (cold), psi	Rolling Resistance		
		$t = 0$	$t = 10 \text{ min}$	$t = t_e$
1220	25	28.64	22.38	20.88
1220	35	23.27	17.30	16.41
1220	45	19.54	14.92	14.17
960	35	16.26	12.38	11.63
1480	35	27.45	20.88	18.95

TABLE III.-TEST DATA FOR 8.00R 16.5 LT TIRE

Dia. = 28.34 in.

Tire Load, lb	Inflation Pressure (cold), psi	Rolling Resistance		
		$t = 0$	$t = 10 \text{ min}$	$t = t_e$
1610	45	24.62	16.97	15.01
1610	55	22.06	15.77	14.41
1610	65	19.82	15.01	13.51
1380	55	17.71	13.51	12.61
1840	55	24.62	17.45	15.92

TABLE IV.- TEST DATA FOR 8.75R 16.5 LT TIRE

Dia. = 29.46 in.

Tire Load, lb	Inflation Pressure (cold), psi	Rolling Resistance		
		t = 0	t = 10 min	t = t _e
1850	45	27.19	18.52	16.73
1850	55	25.39	17.68	15.53
1850	65	18.82	16.43	15.53
1590	55	20.00	15.28	14.93
2110	55	27.47	19.70	17.61

TABLE V.-TEST DATA FOR 9.50-16.5 LT TIRE

Dia. = 30.56 in.

Tire Load, lb	Inflation Pressure (cold), psi	Rolling Resistance		
		t = 0	t = 10 min	t = t _e
2190	40	40.07	28.80	24.04
2190	50	32.95	25.53	22.12
2190	60	29.09	22.12	20.19
1880	50	26.72	20.78	18.41
2500	50	38.00	28.50	24.34

TABLE VI.-COEFFICIENT OF ROLLING RESISTANCE FOR LIGHT TRUCK TIRES AT TYPICAL LOADS AND PRESSURES

Tire Size	(A) Inflation Pressure (cold), psi	(B) 80% Tire Load at Maximum Pressure	Equilibrium Rolling Resistance at Conditions A,B	Coefficient of Rolling Resistance, lb/1000 lb
7.00-15 LT	35	1220	16.41	13.45
8.00R 16.5	55	1610	14.41	8.95
8.75R 16.5	55	1850	15.53	8.39
9.50-16.5 LT	50	2190	22.12	10.10

The reduction in rolling resistance as the tire warms up can be expressed as the ratio of rolling resistance at equilibrium to that at the cold, or initial, state. This data is given in Figure 19 for the same group of tires described in Figures 17 and 18. There seems to be very little trend to this data. There may be some small differences between bias and radial tires since bias constructions seem to exhibit a slightly lower ratio of equilibrium drag to initial drag, but other than that, size, aspect ratio, and load range seem to matter very little.

The tires used in the tests plotted in Figures 17 and 18 were manufactured by a variety of different American manufacturers in 1973 - 1975, and their detailed description is given in Table I of this report.

From Figure 3 it was observed earlier that the equilibrium running state of the tire appears to be reached somewhere after 10 to 20 minutes running, and at 30 minutes of operation at a reasonable speed such as 50 mph, most passenger car tires are almost at their equilibrium temperature state and hence at the steady state value of their rolling resistance. Approximate methods for calculating such warm-up times have been presented in the past [5]. Generally such warm-up times are of value for studying the fuel consumption characteristics of vehicles in short urban trips, but there is some interest also in the length of time necessary for the tire to be stationary in order for it to cool down to its ambient state and again regain its high value of initial rolling loss. A short study done on this for the present report shows that tire rolling resistance as a function of cooling time may be plotted approximately in Figure 20, where the cooling time is measured from the tire rolling resistance equilibrium value, as indicated at time $t = 0$ on Figure 20. From this data it was concluded that the time to regain the cool state is substantially longer than the warm-up time, which is consistent with the approximate heat transfer coefficients that would be appropriate for the moving and stationary states of the tire. Such information is also of value in the study of short urban driving cycles.

Some considerable interest has been shown in the role of tire wear in modifying the rolling resistance of a new tire, since essentially all of the measurements which have been made on tire rolling resistance have been done on new tires. For the purposes of this study, two pairs of tires with very specific characteristics were collected from used automobiles. Each of these pairs was made up of one tire which was nearly at its fully worn condition, while the second tire had been kept as a spare and was essentially unworn. These tires were tested for rolling resistance under identical conditions of inflation, load, and time, and their results reported for purposes of this report. Subsequent to this test program, each of the worn tires of the pair was retreaded by a commercial retreader and the tire again measured for its rolling resistance value. The results of these measurements are shown in Figure 21, where it is seen that in both cases the retreaded tire shows higher rolling loss than either the new tire or its worn counterpart. Caution should be used in interpreting this as a general result due to the small amount of data on this subject.

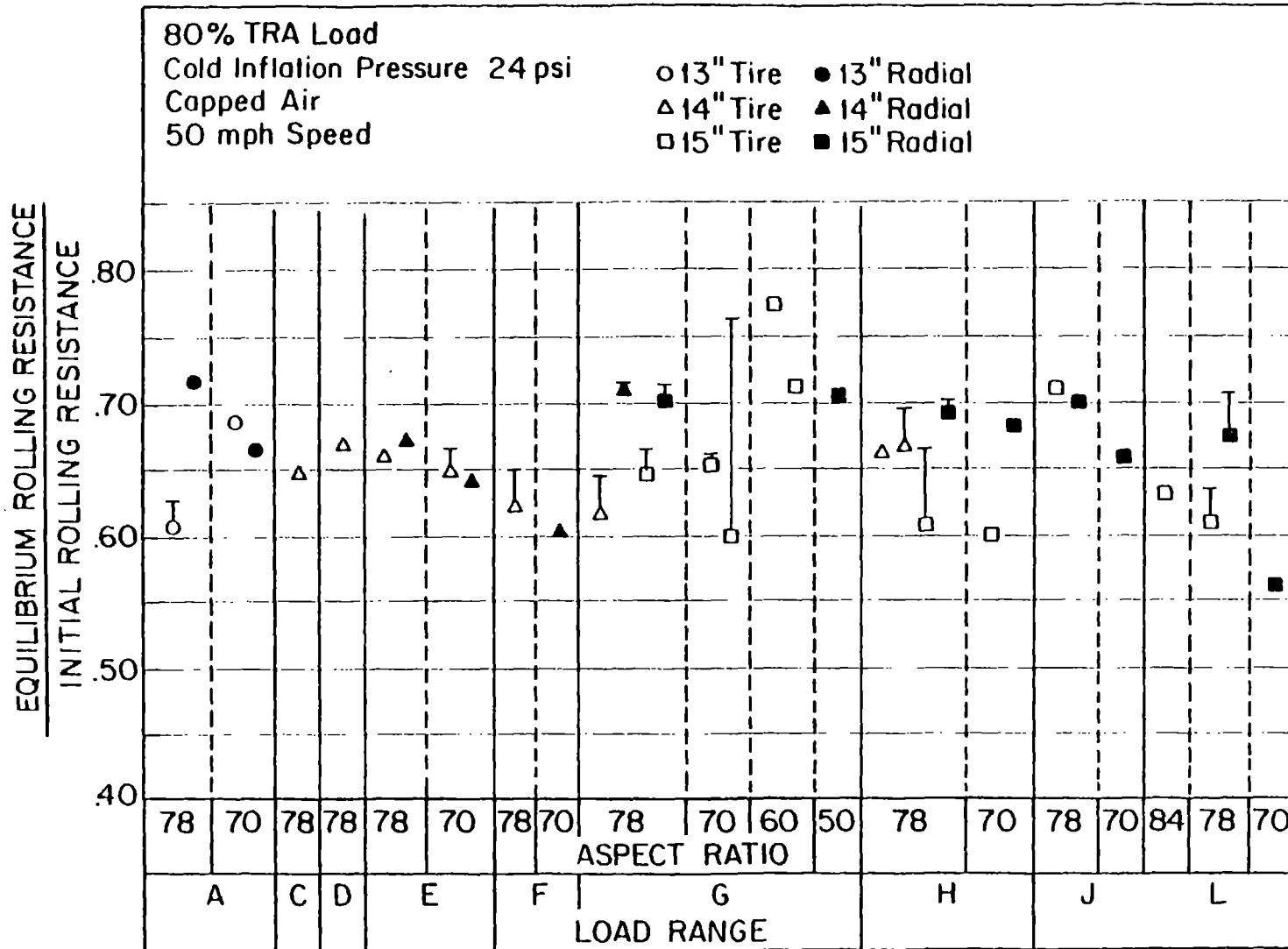

FIGURE 19. RATIO OF EQUILIBRIUM ROLLING RESISTANCE TO INITIAL ROLLING RESISTANCE FOR A SELECTION OF PASSENGER CAR TIRES

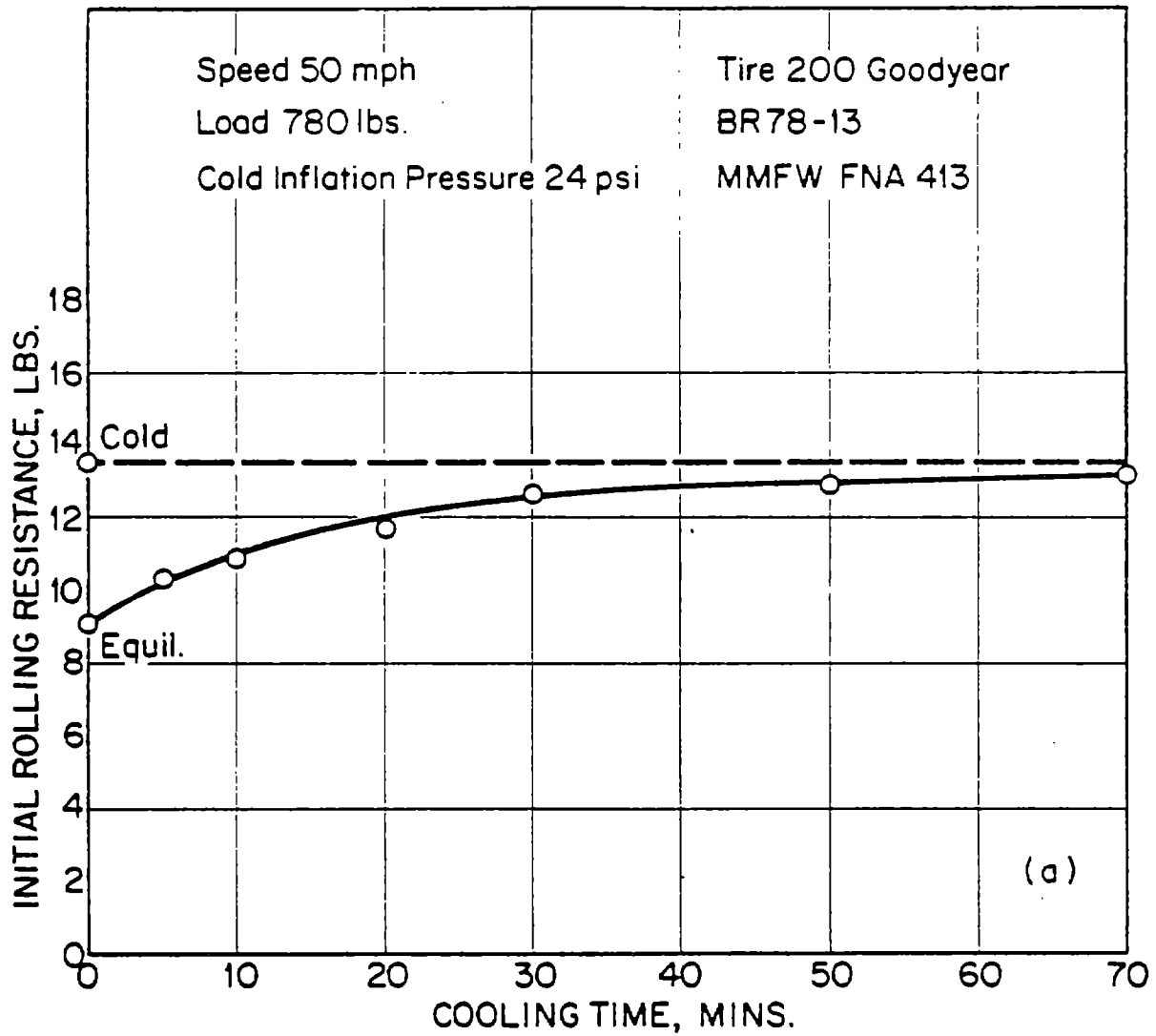

FIGURE 20. ROLLING RESISTANCE VS. COOLING TIME

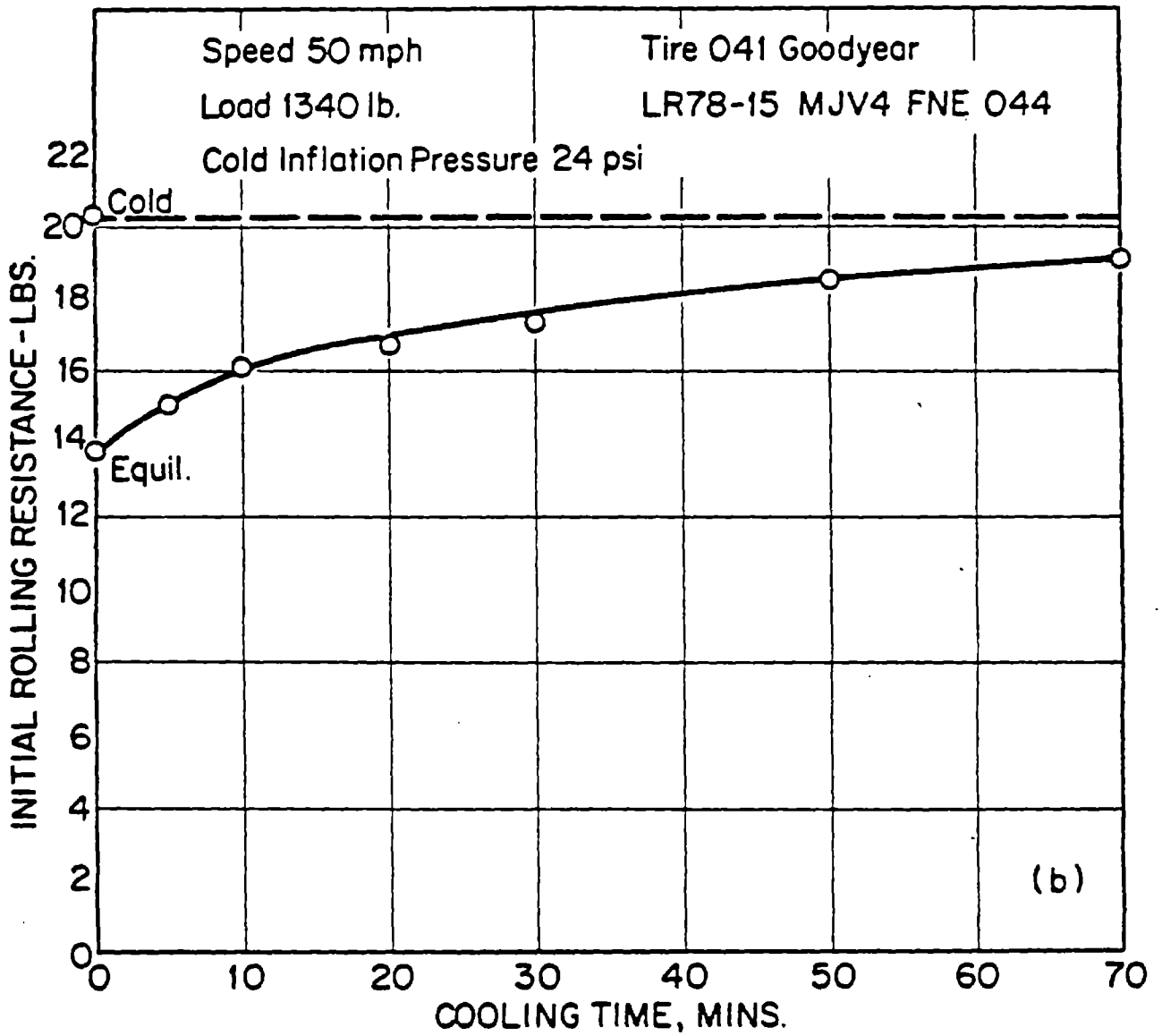

FIGURE 20. CONTINUED

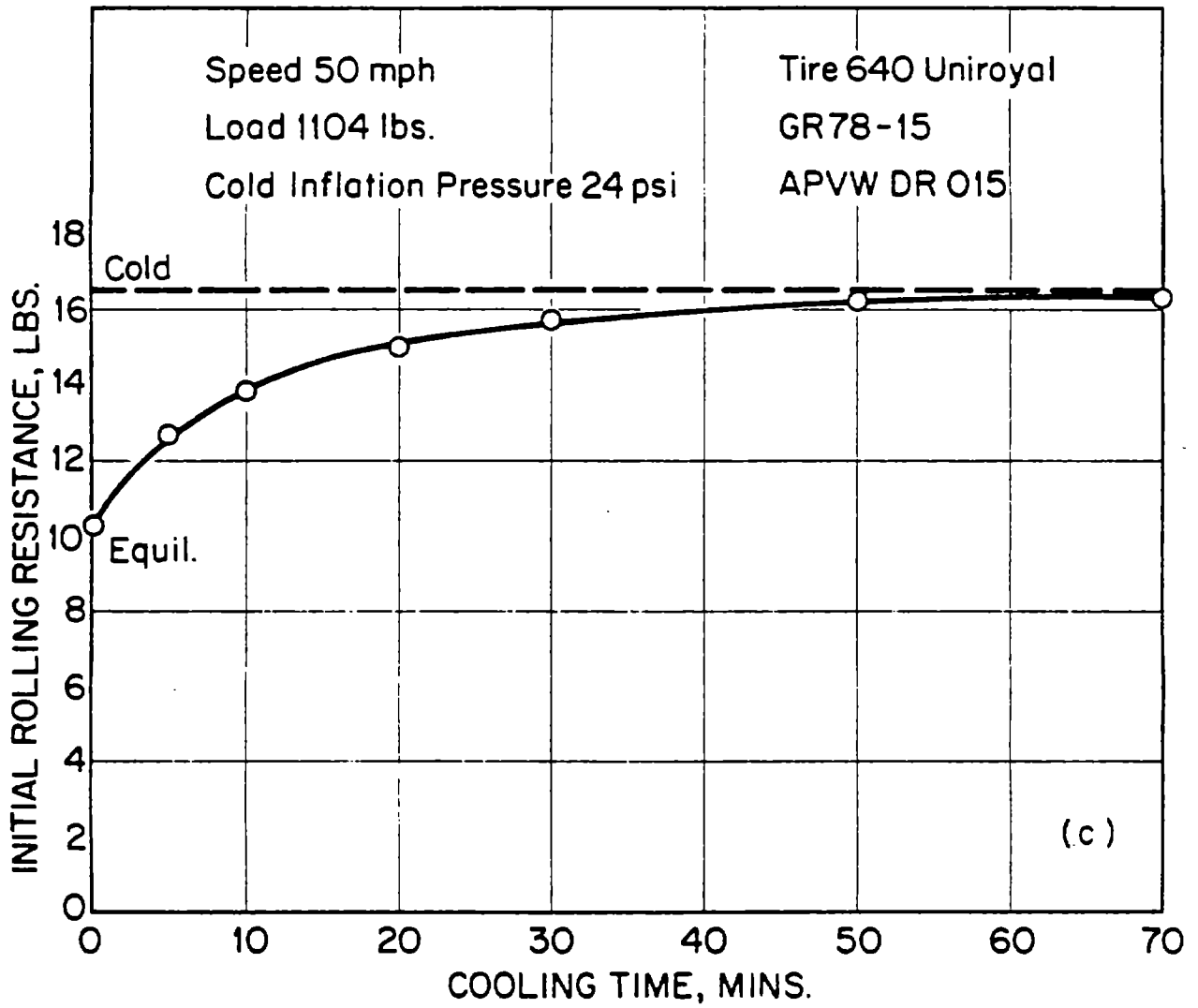

FIGURE 20. CONTINUED

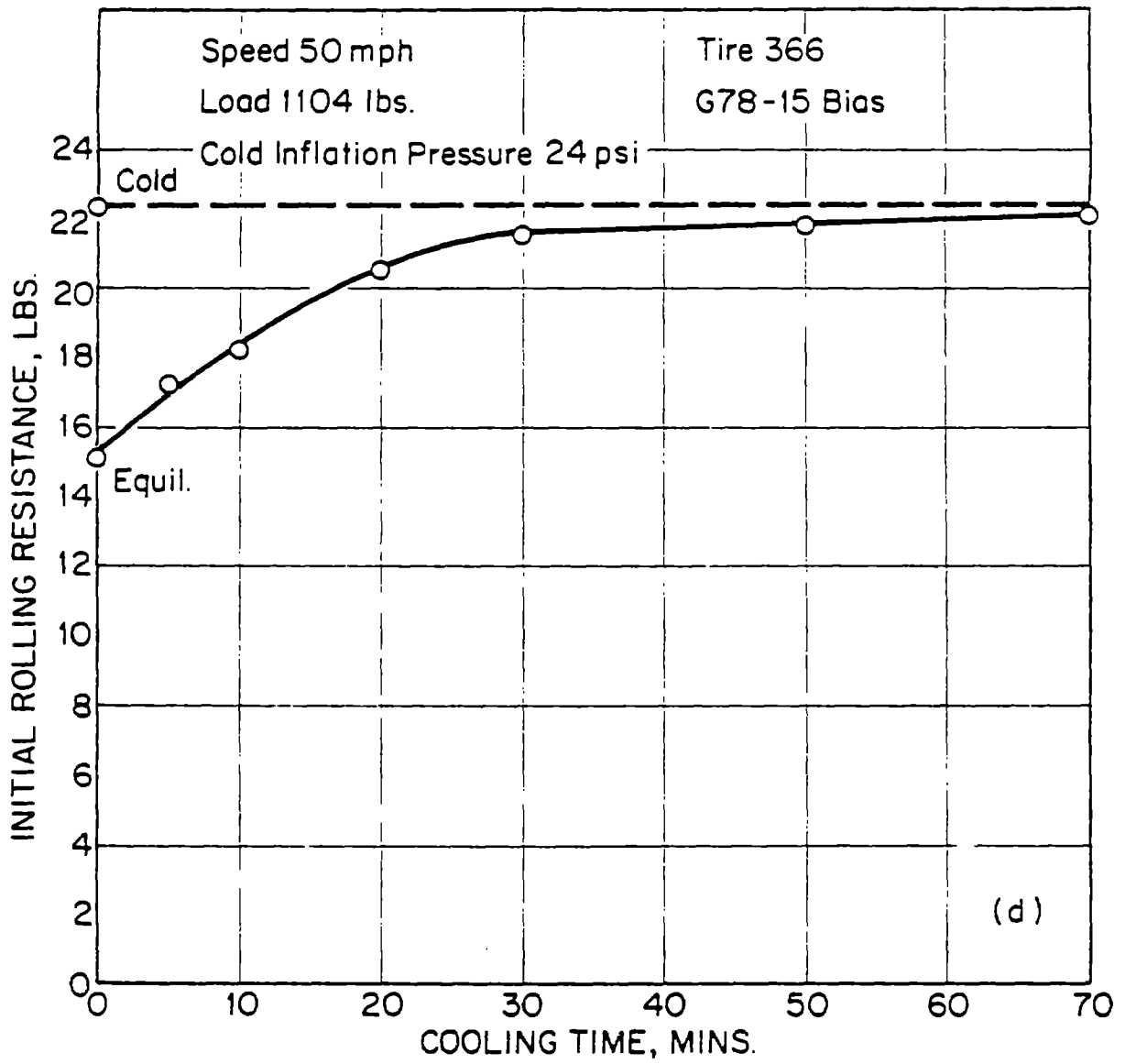

FIGURE 20. CONTINUED

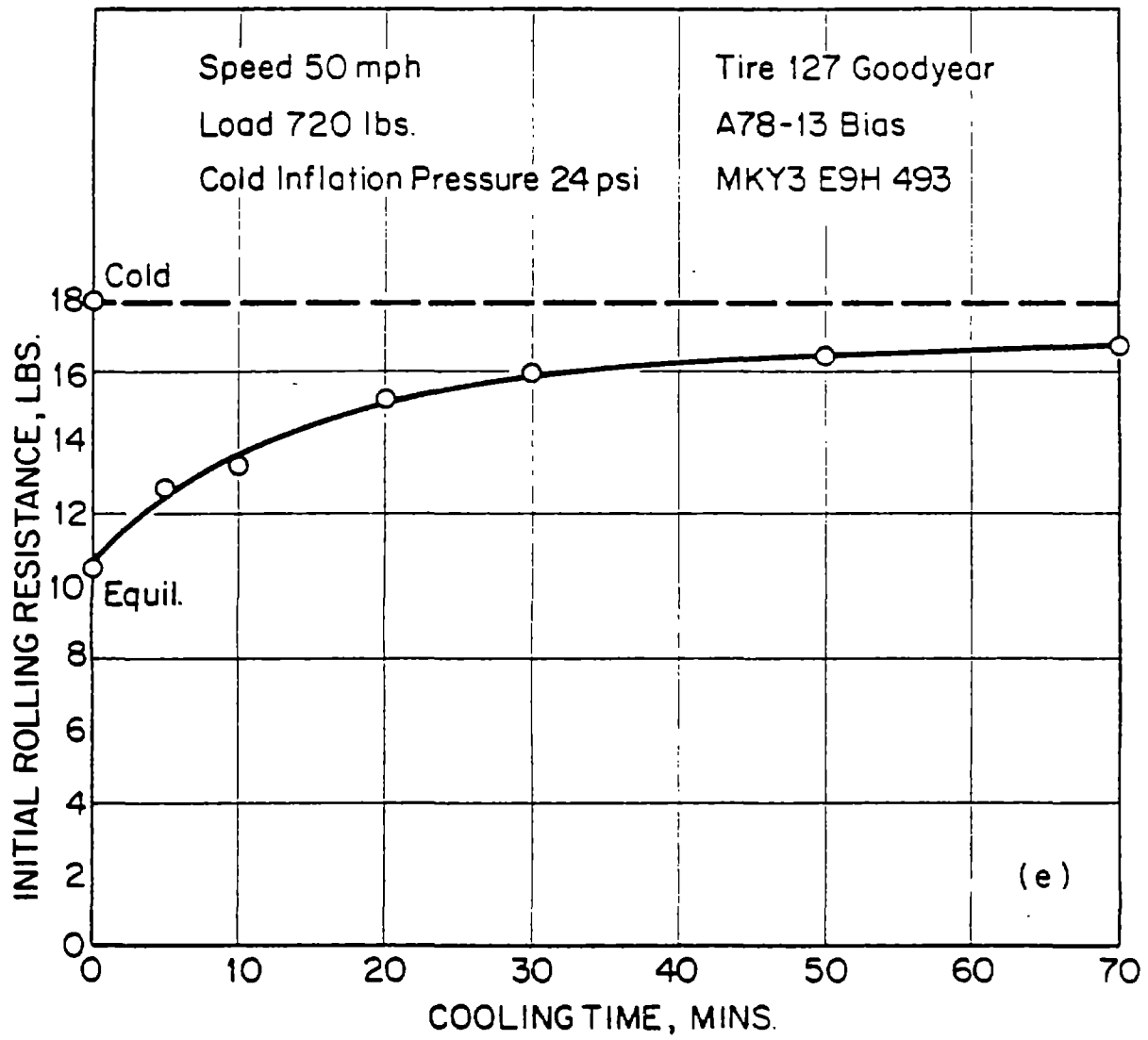

FIGURE 20. CONCLUDED

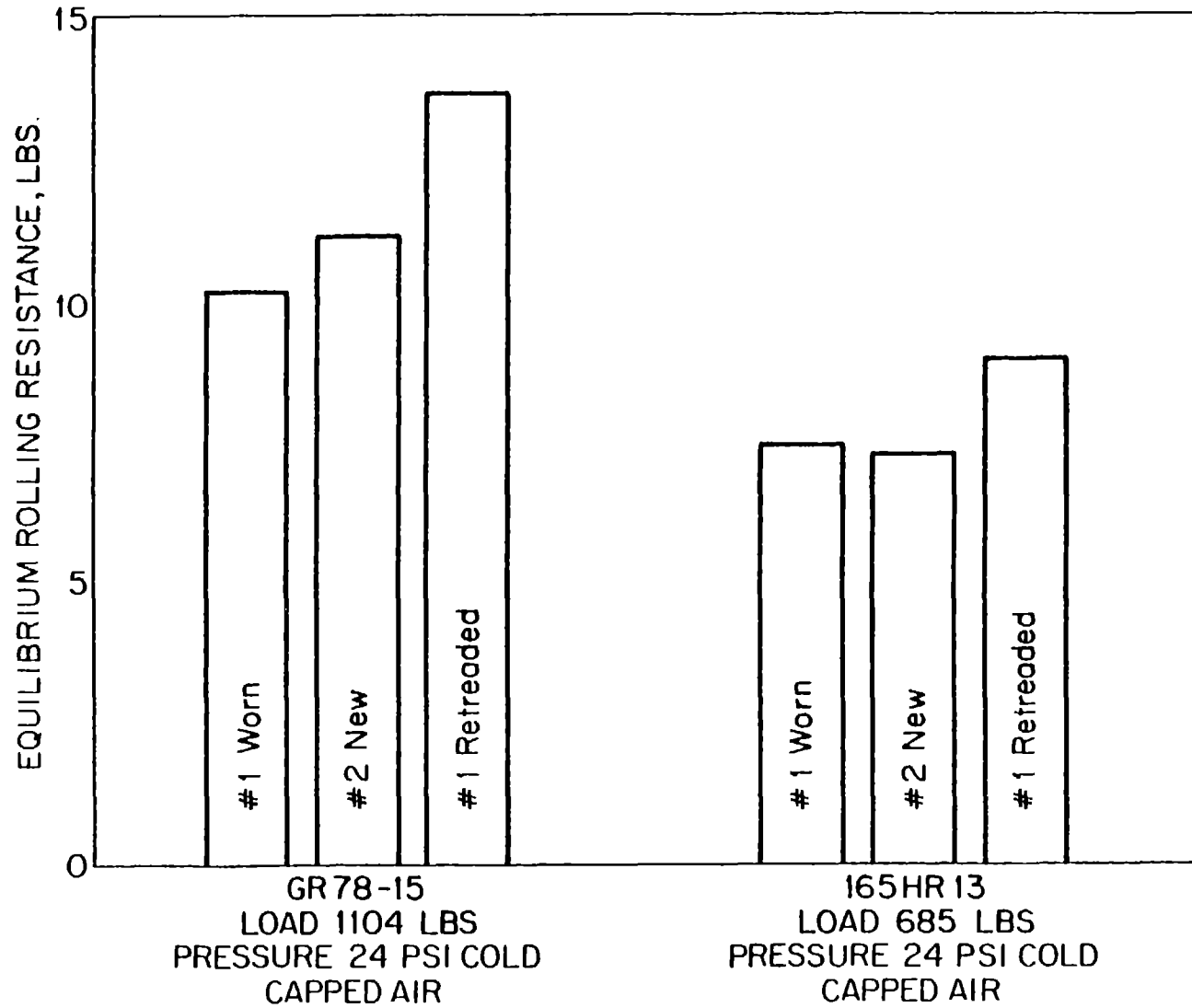

FIGURE 21. EQUILIBRIUM ROLLING RESISTANCE VALUES FOR NEW, WORN, AND RETREADED TIRES OF THE SAME TYPE

Caution should also be used in using this result as indicative of the amount of rolling loss that can be assigned to the tread of a tire. At first glance it might appear that the influence of the tread is reasonably small in determining the overall rolling loss of the tire. However, it should be recognized that a worn tire exhibits a somewhat different pattern in its carcass than does a new tire. This probably means that one cannot use the relationship between a fully worn or buffed tire and a new tire as indicative of the contribution of the tread alone, since the increased deformation of the carcass tends to mask the tread effect. This point needs further study and experiment.

Finally, the problem of tire selection for a given vehicle requires further elaboration. If rolling resistance is the only, or more important criterion, the data of Figures 17 and 18 show that the best strategy is to select an over-size tire and operate it in an under-loaded condition. This is confirmed by test data obtained specifically for this report, where several tires of different load ratings were run at identical loads, most of the underloaded. The equilibrium values of the rolling resistance are given in Table VII as illustrative of this phenomenon.

TABLE VII.-EQUILIBRIUM ROLLING RESISTANCE FOR TIRES OF VARIOUS SIZES UNDER THE SAME LOAD

TIRE	MFGR	LOAD / RATED LOAD	EQUILIBRIUM ROLLING RESISTANCE, lbs
C78-14	Goodyear 2P+2F/2P	840/1050	11.44
E78-14	Dunlop 2P+2F/2P	840/1190	10.03
F78-14	Dunlop 4P	840/1280	9.55
H78-14	Goodyear 2P+2F/2P	840/1510	9.63
GR78-15	Goodrich 2P+2S/2P	1104/1380	12.49
LR78-15	Goodrich 2P+2S/2P	1104/1680	11.97

4. MEASUREMENT METHODS AND DATA REDUCTION IN ROLLING LOSS MEASUREMENTS

Most rolling resistance measurements are made on indoor cylindrical roadwheels for a variety of reasons. The most important of these reasons is the need for very accurate, reproducible measuring systems independent of weather effects, and the need to warm the tire up thoroughly prior to measuring its equilibrium rolling resistance, starting from a common temperature state. All this is most easily done indoors, and by far the most common indoor equipment is the cylindrical roadwheel.

It is necessary to clearly define the relationships between quantities measured on cylindrical roadwheels and those measured on the road, since in the final analysis it is the rolling resistance on the road that influences vehicle fuel economy.

The details of the derivations of the various relationships are given in the Appendix. Most of these have appeared in previous reports [6]. The results of the analyses in the Appendix may be summarized into separate effects, one due to tire stress and one due to measurement methods.

4.1 STRESS EFFECTS

For the same tire load and inflation pressure the rolling resistance of a tire on a curved drum of radius R is greater than on a flat surface due to increased stress levels in the tire. The relationship between these is

$$F_{X_R} = F_r \left(1 + \frac{r}{R} \right)^{1/2} \quad (2)$$

where

F_{X_R} = rolling resistance on a drum of radius R

F_r = rolling resistance on the highway

r = outside radius of the tire

R = drum radius

4.2 MEASUREMENT GEOMETRY

(A) The rolling resistance on a curved drum, as measured by an axle force transducer, is less than the rolling resistance F_{X_R} due to the interaction of

normal forces with measured rolling loss. This is caused by elastic deformation of the tire. The relationship between the two is

$$F_{x_M} = F_{x_R} \left(1 + \frac{r_L}{R} \right) \quad (3)$$

where

F_{x_M} = rolling resistance obtained from axle force measurements, taken on a drum of radius R

r_L = loaded radius (axle height) of the tire above drum surface

F_{x_R} = actual rolling resistance of the tire on the curved drum

(B) The rolling resistance on a curved drum, when measured by either drum shaft torque, coast down or motor electrical power converted to torque, is given by Eq. (4)

$$F_{x_R} = \frac{T_w}{R} \quad (4)$$

where T_w is the drum axle or drag torque and R is the drum radius. F_{x_R} is again the actual rolling resistance of the tire on the curved drum.

(C) When a tire is powered to drive a freely rolling drum and the axle force on either the drum or tire is used as a measure of rolling loss, then the rolling resistance of the tire on the curved drum is given by

$$F_{x_R} = F_{x_M} \left(\frac{R + r_L}{r_r} \right) \quad (5)$$

where

r_r = tire rolling radius

4.3 COMBINED EFFECTS

If one wishes to conduct a test on a curved drum maintaining equal tire deflection on the drum as on the road, then only the corrections for measurement geometry, i.e., Eqs. (3) - (5) need be made.

If one wishes to conduct a test on a curved drum using the same tire loads as used on the road, then both correction for stress effects (Eq. (2)) and for measurement geometry must be made. For example, in the case where axle force transducer measurements are used, and the load is held the same between the tire on the drum and the tire on the road, then both corrections given by Eqs. (2) and (3) must be used simultaneously in order to reduce the data to that on the flat surface. This gives Eq. (6).

$$F_{X_M} = F_R \left(1 - \frac{r_u}{R} \right)^{1/2} / \left(1 + \frac{r_u}{R} \right) \quad (6)$$

Load and inflation pressure are the most important variables defining tire rolling resistance. One may observe from Figures 4 - 7 and 8 - 11 that there exists close linearity of the rolling resistance with load on tire and with the reciprocal of inflation pressure. These relations lead to one method of measuring the rolling resistance at a selected number of points and using this information to predict the rolling resistance of the same tire at other load and pressure values. This consists of expressing the tire rolling resistance in the form of Eq. (7).

$$F_R = F_{R_0} + K_L(F_Z - F_{Z_0}) - K_P \left(\frac{1}{p} - \frac{1}{p_0} \right) \quad (7)$$

where

F_{R_0} = tire rolling resistance at load F_{Z_0} , pressure p_0

F_R = tire rolling resistance at load F_Z , pressure p

K_L = slope of the load dependence of F_R

K_P = slope of the reciprocal pressure dependence of F_R ,
where $1/p$ is used to define the slope

The slope of the load dependence of rolling resistance K_L is obtained by determining the rolling resistance over a range of loads spanning the appropriate load for the tire in question, and passing the best straight line through these. This is usually done using a single pressure, say p_0 , although it may be done at a variety of pressures. Similarly, K_P , the slope of the pressure dependence of rolling resistance, is carried out by varying $1/p$ over a range of values appropriate for the tire, again either holding the load constant or at a variety of loads. This allows a carpet plot of the rolling resistance of the tire to be constructed, and when the lines of the carpet plot are parallel then Eq. (7) becomes adequate for predication purposes. This is illustrated in Figure 22, where a carpet plot is shown for three different pressures

and three different loads. Such a carpet plot cannot be represented by Eq. (7), since the slope of the load dependence and the pressure dependence are different at the different points. It is necessary to use it in its entirety in order to obtain accurate values of the rolling resistance at points other than those measured.

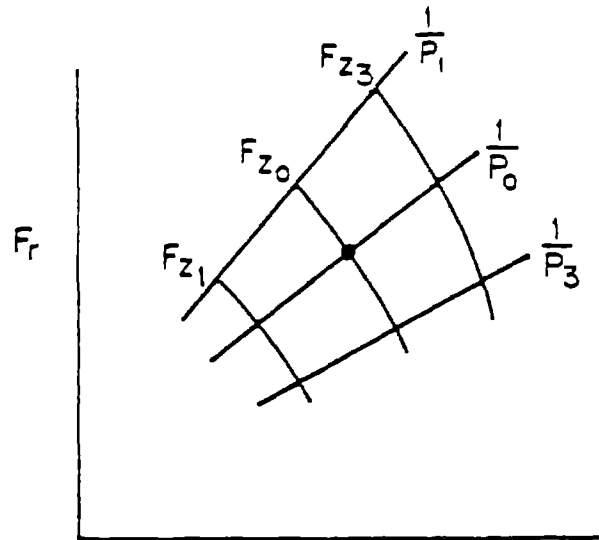

FIGURE 22. CARPET PLOT OF ROLLING RESISTANCE AS A FUNCTION OF LOAD AND PRESSURE

In cases where the slopes or gradients of rolling resistance with load and pressure do not vary significantly, then Eq. (7) becomes an adequate representation and the data may be presented as shown in Figure 23.

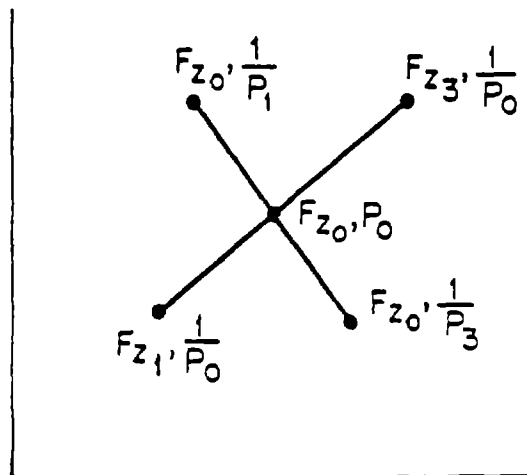

FIGURE 23. FIVE POINT CARPET PLOT

In Figure 23, as in Figure 22, the data may be obtained using either capped air or regulated air test conditions. In the capped air condition, the tire is inflated at room or ambient temperature to the specified initial pressure, and then run under the appropriate load until rolling resistance equilibrium is reached. During this process temperature will rise as will inflation pressure. Nevertheless, the plots are made using the initial inflation pressures of the tire.

An alternate approach, and one which results in more rapid achievement of equilibrium conditions, involves using regulated air conditions in the test program. Here, an estimate is made of some reasonable air pressure buildup which the tire might have during warm-up. This is added to the desired cold inflation pressure and is used as the regulated air value at which rolling resistance is obtained. The air pressure is maintained at this constant value during the warm up process of the tire, and the tire rolling resistance reaches its equilibrium value quicker than in the capped air experiment. This has the advantage of reducing test time in order to obtain data points. The regulated values of pressure are then used to make plots such as Figures 22 or 23. This is a very efficient process in terms of test time, since in the case of Figure 22 it requires nine points to obtain an adequate carpet plot over a range of loads and pressures, while in Figure 23 only five points are required. In the case of regulated air, it has been reported that equilibrium times can be reached in approximately 10 to 15 minutes, while in the case of capped air 20 to 30 minutes are needed.

An alternate approach to that of Eq. (7) uses a somewhat different view of the dependence of rolling resistance on load and pressure in order to give a predictive framework which is more general. This concept begins with the observation that there is a nearly linear relationship through the origin of the tire equilibrium rolling resistance versus load curve, and an equally linear relationship between the reciprocal of cold inflation pressure and rolling resistance, although here the linear extrapolation does not pass through the origin. This is clearly seen by reference to Figures 4-7 and 8-11. This gives rise to a general form for the dependence of equilibrium rolling resistance on load and pressure, given in Eq. (8).

$$F_r = F_{r_0} \left(\frac{F_z}{F_{z_0}} \right) \left(c_p \cdot \frac{p_0}{p} + c_T \right) \quad (8)$$

where

c_p, c_T = constants for each tire

$F_r, F_{r_0}, F_z, F_{z_0}, p, p_0$ defined as in Eq. (7)

Note that a further requirement is that

$$c_p + c_T = 1 \quad (9)$$

Combining Eqs. (8) and (9) leads to

$$F_r = F_{r_0} \left(\frac{F_z}{F_{z_0}} \right) \left[1 + c_p \left(\frac{p_0}{p} - 1 \right) \right] \quad (10)$$

which is an expression for rolling resistance at any load and pressure as a function of the rolling resistance F_{r_0} at some base-line conditions of load F_{z_0} and pressure p_0 . This expression contains only one constant c_p , characteristic of the tire, and expressing the sensitivity of that tire's rolling resistance to inflation pressure. Hence the use of the symbol c_p denoting a pressure coefficient is appropriate.

This means that the entire load-pressure-rolling resistance map of a tire can be determined if one value of the rolling resistance F_{r_0} is known at one load F_{z_0} and one inflation pressure p_0 , provided that the constant c_p is also known for the tire. This constant may be determined most easily by fixing load F_{z_0} at its base-line value and measuring the tire rolling resistance over several pressures, such as shown in Figure 24.

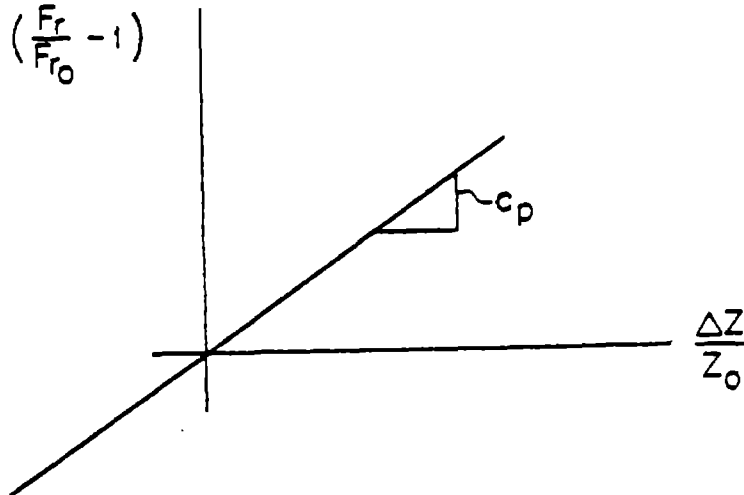

FIGURE 24. GRAPHICAL REPRESENTATION OF THE SLOPE NEEDED TO DETERMINE THE CONSTANT FOR TIRE PREDICTIONS

As is clear from that figure, only a limited number of tests are necessary to determine the constant c_p . A minimum of two would be necessary, but it would be much more desirable to use at least three points in order to obtain a check on the linearity of the data.

This has been done for four passenger car tires, one light truck tire under a test program carried out for this report, and the results are presented in Table VIII. In each case, three points were used to determine the constant c_p for each of the five tires, following which this constant for each tire was used to predict other rolling resistance values at different loads and pressures. These were compared with test data obtained from the same tires. From the predictions of Table VIII and the corresponding measurements it appears that to a close approximation the rolling resistance of the tire can be determined as a function of load and initial pressure using Eq. (10), with the constant c_p being determined experimentally by three points. In the case of the passenger car tire data of Table VIII those points were obtained by capped air tests with the tire inflated from cold inflation conditions. Similar computations were carried out for the rolling resistance of a light truck tire, and the results of these are shown in Table IX. Here the data was obtained from regulated air tests, so the method appears to work well for both techniques.

TABLE VIII.-MEASURED VS. CALCULATED VALUES OF ROLLING RESISTANCE USING EQ. (10)

		GOODYEAR G78-14 BIAS $c_p = .564^*$ S/N CKL9 E24443		FIRESTONE H78-15 BIAS $c_p = .468^{**}$ S/N WKVXVEE 145		GOODYEAR GR78-14 RAD $c_p = .456^*$ S/N MKMA HCE354		UNIROYAL HR78-15 RAD $c_p = .547^{**}$ S/N APVY EZ 025	
LOAD	PRES	PREDIC.	MEAS.	PREDIC.	MEAS.	PREDIC.	MEAS.	PREDIC.	MEAS.
828	20	13.10	13.59			9.42	9.54		
828	24	11.78	11.32			8.63	8.79		
966	18	16.32	16.61			11.60	11.66		
1104	20	17.47	17.52			12.56	12.42		
1104	28	14.44	14.49			10.76	10.45		
1380	24	19.63	19.93			14.39	14.24		
1380	28	18.04	19.62			13.45	13.02		
1656	24	23.55	23.70			17.27	16.35		
906	20			13.28	13.80			9.76	9.93
906	24			12.14	11.55			8.80	8.72
1057	18			16.38	16.49			12.14	12.19
1208	20			17.71	17.99			13.01	12.78
1208	28			15.11	15.30			10.81	10.84
1208	32			14.30	14.24			10.13	10.98
1510	24			20.24	21.29			14.66	14.74
1510	28			18.88	19.64			13.52	14.14
1812	24			24.28	25.19			17.60	18.05

*Determined from $F_{z0} = 1104, p_1 = 16, p_0 = 24, p_3 = 32$ psi cold

**Determined from $F_{z0} = 1208, p_1 = 16, p_0 = 24, p_3 = 32$ psi cold

TABLE IX.-MEASURED AND PREDICTED EQUILIBRIUM ROLLING RESISTANCE USING EQ. (10)

67-inch drum
 8.75 R-16.5 Light Truck Tire
 $c_p = 0.325$ Abs. Avg. Error = 0.33 lb
 (Calculated values are in parentheses just below the measured values.)

	500 lb	1000 lb	1500 lb	2000 lb	2500 lb	3000 lb
20 psi	6.25 (6.89)	13.80 (13.78)	21.10 (20.68)			
35 psi	5.25 (5.28)	10.70 (10.56)	15.90 (15.84)			
50 psi	4.95 (4.63)	9.50 (9.27)	13.90 (13.90)	18.50 (18.53)	22.80 (23.17)	
65 psi	4.85 (4.29)	8.80 (8.57)	12.90 (12.86)	16.80 (17.14)	20.80 (21.40)	24.80 (25.70)
80 psi	4.75 (4.07)	8.70 (8.13)	12.40 (12.20)	16.00 (16.27)	19.90 (20.30)	23.80 (24.40)

5. DESCRIPTION OF TEST METHODS

The data quoted in this handbook has not been taken from the existing literature but instead relies entirely on measurements of the tire rolling resistance carried out especially for this study. The tires in question were furnished by the U.S. Department of Transportation and were thoroughly broken in by virtue of having been used for cornering force measurement studies at Calspan, Inc., Buffalo, N.Y.

Rolling resistance measurements were carried out on these tires by the B. F. Goodrich Research Laboratories, Brecksville, Ohio under the direction of Dr. Marion Pottlinger and Mr. David Strelow. The test equipment used was a 67-inch diameter steel roadwheel with smooth steel surface, and torque was measured with a shaft torque meter whose output was filtered and recorded on a strip chart recorder.

Tests were controlled by specifying tire load. Hence, it was necessary to divide all measured rolling resistance forces by the quantity

$$\left(1 + \frac{L}{R}\right)^{1/2} \quad \text{[c.f. Eq. (2)]}$$

in order to obtain the rolling resistance force which the tire would exhibit on a flat test surface. These reduced values have been used in reporting all the data given in this report.

All tests were run under capped air conditions, and all pressures are the cold inflation pressures.

6. BIBLIOGRAPHY

- [1] General Motors Corporation Comments on Tire Rolling Resistance to U.S. Environmental Protection Agency, February 23, 1978.
- [2] Bidwell, J. B., "Conserving Vehicle Energy," General Motors Research Report 2218, October 6, 1976.
- [3] Motor Vehicle Manufacturers Association, "Facts and Figures, 1976," p. 52.
- [4] Johnson, T. M., D. L. Formenti, R. F. Gray, and W. C. Peterson, "Measurement of Motor Vehicle Operation Pertinent to Fuel Economy," SAE Paper 750003, February 1975.
- [5] Dodge, R. N., and S. K. Clark, "Tire Transient Temperatures," The University of Michigan, Report 013662-5-I, U.S. Department of Transportation, January 1977.
- [6] Clark, S. K., "Rolling Resistance Forces in Pneumatic Tires," The University of Michigan, Report 013658-1-I, U.S. Department of Transportation, January 1976.

APPENDIX

MEASUREMENT METHODS AND DATA REDUCTION IN ROLLING LOSS MEASUREMENTS

MEASUREMENT GEOMETRY

The measurement of rolling resistance can be a difficult process if care is not taken in clearly defining the relationship between the measured quantities and the true rolling resistance of the tire. This is because the direct application of the rolling resistance is to vehicle fuel economy, which occurs on the flat road surface. On the other hand, most rolling resistance measurements are made on cylindrical drums because of their common availability in the tire industry and because they allow sufficient stable running for the tire to reach its thermal equilibrium state. For this reason, it is necessary to clearly define the relationships between quantities measured on cylindrical roadwheels and those observed on the highway. The following analyses attempt to examine the technically important test configurations in order of increasing complexity. For clarity all computations use force resultants only.

CASE 1—FREELY ROLLING TEST TIRE ON FLAT SURFACE

For this case either the tire axle may move or the test surface may move. Figure A-1 shows a free body diagram of the force resultants acting on the tire and wheel.

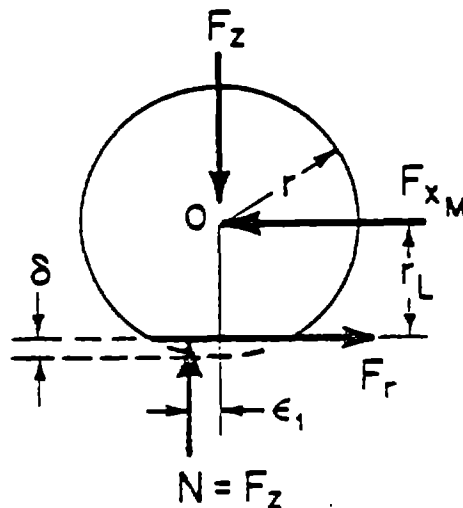

FIGURE A-1. FREE BODY DIAGRAM OF A ROLLING TIRE ON A FLAT SURFACE

There F_r is the tire rolling resistance, while F_{X_M} is the horizontal force measured by an axle force transducer.

$$\sum F_x = 0; \quad F_{X_M} = F_r \quad (A-1)$$

$$\sum F_z = 0; \quad F_z = N \quad (A-2)$$

$$\sum M_o = 0; \quad F_z \epsilon_1 = F_r r_e \quad (A-3)$$

$$\epsilon_1 = \frac{F_r r_e}{F_z}$$

The measured horizontal force is the tire rolling resistance. The vertical force resultant moves forward by an offset ϵ_1 as given in Eq. (A-3).

This is the type of measurement which is carried out on the TIRF machine at Calspan, Inc., Buffalo, N.Y., or alternately is the type of measurement which would be obtained by an instrumented axle force transducer on a vehicle or a trailer.

An alternate version of this type of motion is given in Case 2 below.

CASE 2—TEST TIRE UNDER TORQUE AT CONSTANT VELOCITY ON FLAT SURFACE

In this case, a torque applied to the tire is used to propel to the right at a constant velocity, where the notation is the same as used in Figure A-1. The appropriate equations of equilibrium are given by

$$\sum F_y = 0; \quad F_z = N$$

$$\sum M = 0; \quad N \epsilon_2 = T \quad (A-4)$$

$$\epsilon_2 = \frac{T}{F_z}$$

The torque shown in Figure A-2 is just sufficient to sustain the rolling losses of the tire and to move the tire and wheel at constant velocity to the right.

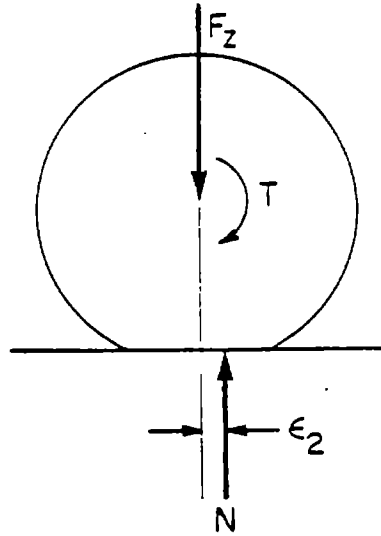

FIGURE A-2. FREE BODY DIAGRAM OF A ROLLING TIRE ON A FLAT SURFACE UNDER APPLIED TORQUE

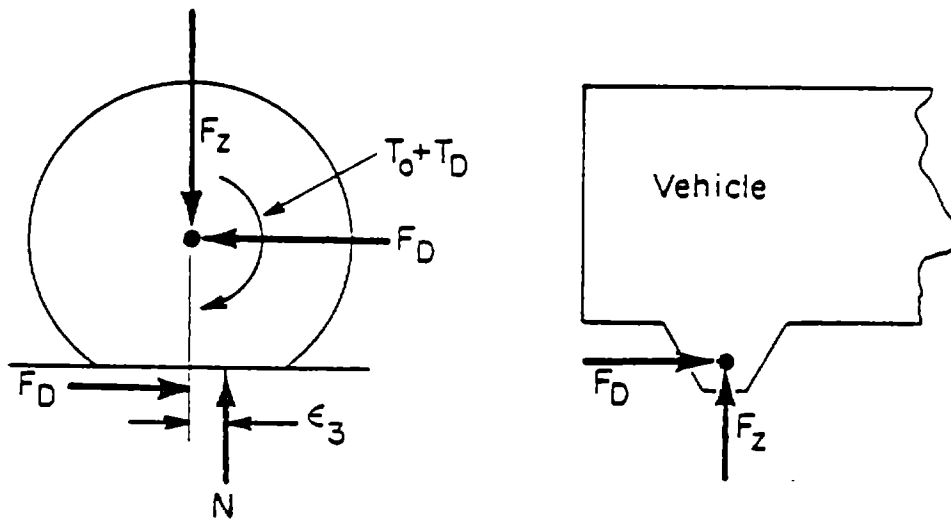

FIGURE A-3. FREE BODY DIAGRAM OF A POWERED TIRE DRIVING A VEHICLE

Figures A-1 and A-2 may be related by consideration of the work done in one complete revolution of the tire by the force acting to move it. Equating the work done in the two cases gives

$$F_r \cdot 2\pi \cdot r_r = T \cdot 2\pi$$

where r_r is the rolling radius, gives

$$r_r = r - \frac{\delta}{2} \quad (A-5)$$

where δ is the tire deflection. Using Eqs. (A-3) and (A-4)

$$\epsilon_1 = \frac{F_{y1} r}{F_z \frac{\delta}{2}}$$

$$\epsilon_2 = \frac{F_{y2} r}{F_z} = \frac{F_{y2} r_r}{F_z}$$

and

$$\frac{\epsilon_1}{\epsilon_2} = \frac{r}{r_r} \neq 1$$

so that normal force resultant offsets are not the same in the two cases. If additional torque is applied, then the wheel will either accelerate or will be capable of exerting a force on a vehicle in order to propel it forward at constant velocity. This is illustrated in Figure A-3, where the driving force is denoted as F_D and is shown acting on the driven tire and in an opposite sense on the vehicle which it propels. Again the offset of the vertical force resultant is denoted by ϵ_3 , and this may be different from that of the freely rolling cases such as shown in Figures A-1 or A-2.

CASE 3—TIRE OPERATION ON A CYLINDRICAL SURFACE

The tire is assumed to conform to the cylindrical drum as shown in Figure A-4. The drum rotates clockwise due to a clockwise torque T_D . The wheel is also subjected to a driving torque T_W .

The free body diagram of the tire in Figure A-4 shows the forces acting on the tire. These are normal and tangential to the drum surface, being denoted by the normal force N and the tire rolling resistance, F_{XR} , now offset by an arc length ϵ_4 along the drum surface from the vertical line of centers.

Each element of drum surface has acting on it a pressure component normal to the surface and one tangential to it. The component normal to the surface passes through the drum center causing no moment about the center. Hence, the resultant of the normal forces, made up to the sum of the small incremental normal components, cannot cause any moment about the drum center and must be perpendicular to the drum surface. The sum of tangential components forms a

resultant tangential force at the drum surface, essentially perpendicular to the normal force resultant, i.e., tangent to the drum. This tangential component is the rolling resistance force of the tire as measured on the drum of radius R .

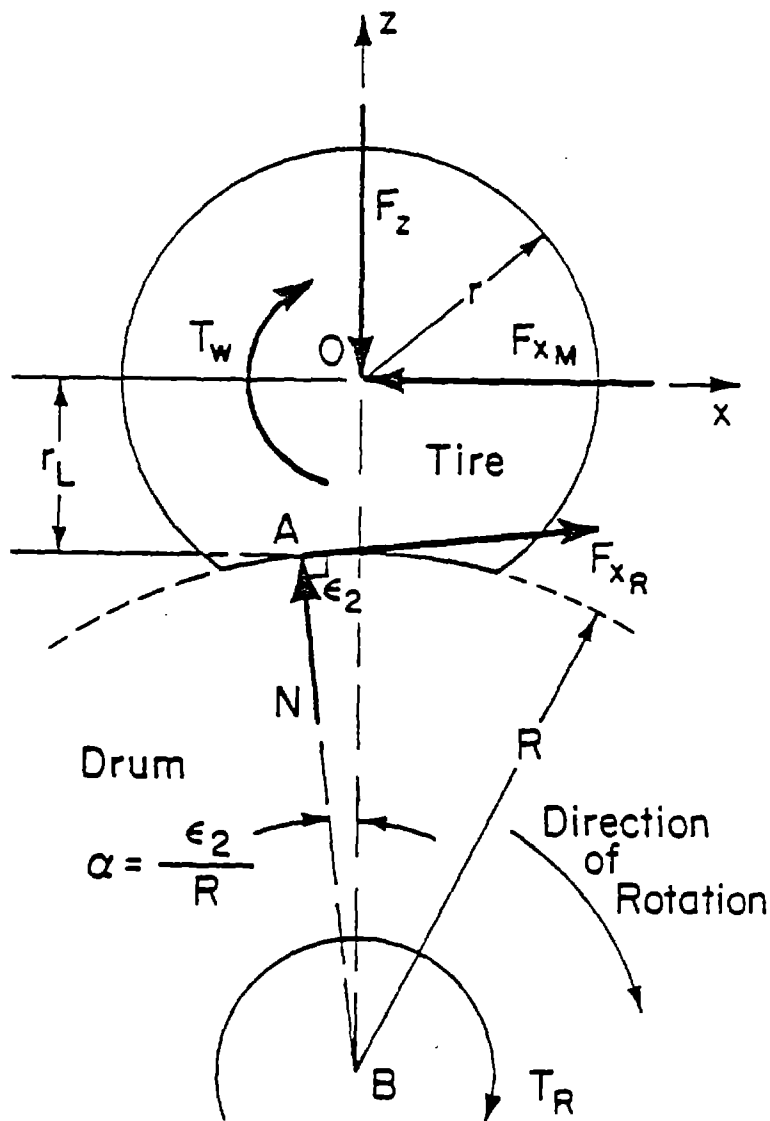

FIGURE A-4. RESULTANT FORCES ON THE TIRE WHILE ROLLING ON A TEST DRUM

A horizontal force F_{xM} is shown at right angles to the center line between the drum and the tire. This is the force normally measured by an axle force transducer. The equations of equilibrium for the tire itself are written below, and are used to solve for the unknown F_{xM} in terms of the other variables:

$$\sum F_z = 0; \quad -F_z - F_{xR} \sin \alpha - N \cos \alpha = 0 \quad (A-6)$$

Assume $F_{X_R} \ll F_Z$ and α small. Then

$$F_Z \cong N \quad (A-7)$$

$$\sum F_X = 0; \quad -F_{X_M} + F_{X_R} \cos \alpha - N \sin \alpha = 0$$

or

$$F_{X_M} = F_{X_R} - \alpha F_Z \quad (A-8)$$

$$\sum M_A = 0; \quad -F_Z \cdot \epsilon_L + F_{X_M} r_L - T_w = 0 \quad (A-9)$$

where r_L is the axle height above the drum surface. Using Eq. (A-8) and the relation $\epsilon_L = R\alpha$ in Eq. (A-9) gives

$$F_Z \cdot R\alpha = (F_{X_R} - \alpha F_Z) r_L - T_w$$

or

$$\alpha = \frac{F_{X_R}}{F_Z} \left(\frac{r_L}{R+r_L} \right) \frac{T_w}{F_Z(R+r_L)} \quad (A-10)$$

This can be used in Eq. (A-8) to give

$$F_{X_M} = F_{X_R} \left(1 + \frac{r_L}{R} \right) + T_w / (R+r_L) \quad (A-11)$$

For an internal drum one uses a negative value for R.

Finally, the torque input T_R to the dynamometer drum can be obtained from the free body diagram of that drum, and by taking moments about point B of Figure A-4 of the drum, one obtains

$$T_R = F_{X_R} \cdot R \quad (A-12)$$

One special case of technical interest can now be considered separately, namely, that of the freely rolling tire where $T_w = 0$. Using Eq. (A-11), one obtains

$$F_{X_M} = F_{X_R} / \left(1 - \frac{r_c}{R} \right) \quad (A-13)$$

This is the condition which commonly is found when a driven dynamometer drum powers a freely rolling tire mounted in bearings on an axle force transducer. The axle force transducer will record the quantity F_{X_M} and from this the rolling resistance force F_{X_R} must be inferred. Using Eq. (A-13) one may observe the relation between the tire rolling resistance force and the axle force transducer measurement. This leads to the conclusion given immediately below.

POWERED DRUM, FREE ROLLING TIRE WITH AXLE FORCE TRANSDUCER MEASUREMENT

Axle force transducer measurements made on a powered drum misrepresent the rolling resistance of the tire on the curved drum, giving a rolling resistance smaller than the true value on a convex drum and larger than the true value of a concave drum. The reason for this is interaction of the contact pressure force resultant with the rolling resistance measurement. To correct such force measurements, the axle force transducer measurement should be multiplied by the factor $(1 + r_c/R)$.

Examination of the free body diagram shown in Figure A-4, shows that the torque on the drum is related to the tire rolling resistance force directly through the drum radius as given in Eq. (A-12). This leads to the common measurement system where either a drum axle torque transducer or motor power meter is used to obtain the torque needed to drive the drum at constant velocity.

SHAFT TORQUE, MOTOR POWER AND COAST DOWN MEASUREMENTS OF FREELY ROLLING TIRE ON CYLINDRICAL DRUM

It may be seen from Eq. (A-12) that either torque, power input or coast down measurements on a powered drum, either convex or concave, reflect the true value of the rolling resistance of the tire on a curved surface, although the rolling resistance may be different from that on a flat surface. In this case, it is only necessary to divide the measured torque by the drum radius in order to obtain the effect of the radius of the drum in question.

Finally, one may note that it is possible to power the tire and to have a freely rolling drum, in which case Eq. (A-11) may be used to interpret the resulting condition. In the case of the freely rolling drum, in the absence of bearing friction, the force F_{X_R} tangent to the drum surface must vanish.

Thus, Eq. (A-11) is left in the form given by Eq. (A-14):

$$T_w = F_{X_M} (R + r_L) \quad (A-14)$$

This may be related to the rolling resistance of the tire in the same way that Figure A-2 relates to Figure A-1, where it may be assumed that the relation between torque necessary to keep the wheel in motion and the force necessary to do the same are given in Eq. (A-15).

$$T_w = F_{X_R} \cdot r_r \quad (A-15)$$

From this one may conclude that the effective rolling resistance of the tire is given by Eq. (A-16):

$$F_{X_R} = F_{X_M} \left(\frac{R + r_L}{r_r} \right) \quad (A-16)$$

This leads to the general rule for measurement of the rolling resistance using a powered tire and a freely rolling drum as given below.

POWERED TIRE AND FREELY ROLLING DRUM, WITH AXLE FORCE MEASUREMENT OR TORQUE MEASUREMENT

Where a powered tire is used to drive a freely rolling drum, the relationship between the torque needed to rotate the tire and drum and the rolling resistance of the tire F_{X_R} as given by Eq. (A-15), or if an axle force transducer is used either on the powered axle or on the drum, the relationships between the measured axle force F_{X_M} and the rolling resistance of the tire F_{X_R} is given by Eq. (A-16).

TIRE STRESS EFFECTS

The previous discussion concerning measurement methods on flat and curved drums considered only the kinematics of determining rolling resistance force on the tire from force or torque measurements made at other convenient locations. No consideration was given in those analyses to the fact that the rolling resistance of the tire at a given load may be different on a curved surface than on a flat surface due to the fact that on a curved surface larger tire deflections are encountered, so that higher cyclic stresses are generated.

To a first approximation, it is now thought that to obtain the same rolling resistance force on a curved drum and on a flat surface, the tire

deflection should be the same on both the drum and flat surface. This means that matching rolling resistance conditions in the two cases requires determination of the tire deflection rather than load. The condition of equal deflections may be used to determine an approximate load by a simplified analysis such as given below.

Assume that the tire diameter conforms to the rigid roadwheel as shown by the dark lines in Figure A-5. The contact path length L is given by

$$L = 2R \sin \gamma = 2r \sin \theta \quad (A-17)$$

Assume both γ and θ to be small angles. Then to a first approximation

$$L \cong 2R \gamma \cong 2r \theta \quad (A-18)$$

The maximum tire deflection δ is given by

$$\delta = r(1 - \cos \theta) + R(1 - \cos \gamma) \quad (A-19)$$

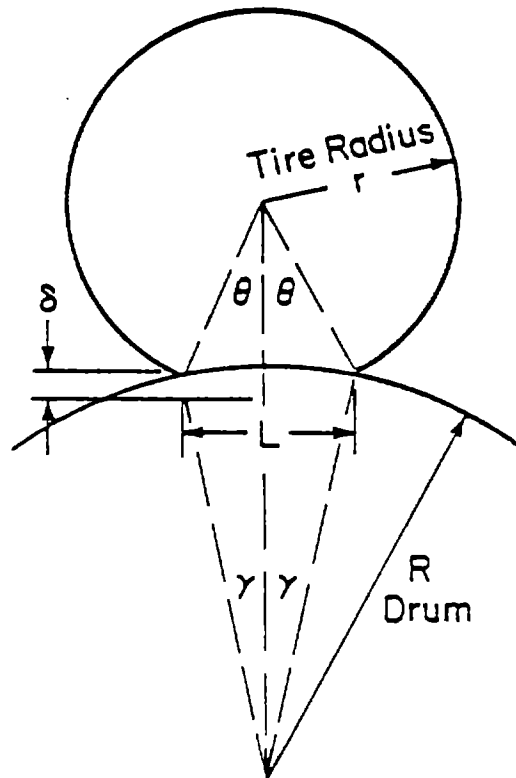

FIGURE A-5. GEOMETRY OF TIRE AND TEST DRUM

Note that for an inside roadwheel one uses Eq. (A-19) but now with a negative value for R

Again assuming small angles, Eq. (A-19) may be written

$$\delta = r \frac{\theta^2}{2} + R \frac{\gamma^2}{2} = \frac{L^2}{2} \left(\frac{1}{r} - \frac{1}{R} \right) \quad (\text{A-20})$$

or

$$\frac{L}{2} = \delta^{1/2} \left(\frac{1}{2r} + \frac{1}{2R} \right)^{-1/2} \quad (\text{A-21})$$

Consider next the cross section of the tire at its center plane, as shown in Figure A-6. The width b of the contact path is given by

$$b = 2r_1 \sin \beta \cong 2r_1 \beta \cong w\beta \quad (\text{A-22})$$

where

w = tire section width

r_1 = radius of tire cross section

Also

$$\delta = r_1 (1 - \cos \beta) \cong \frac{w}{2} \frac{w\beta^2}{2} \quad (\text{A-23})$$

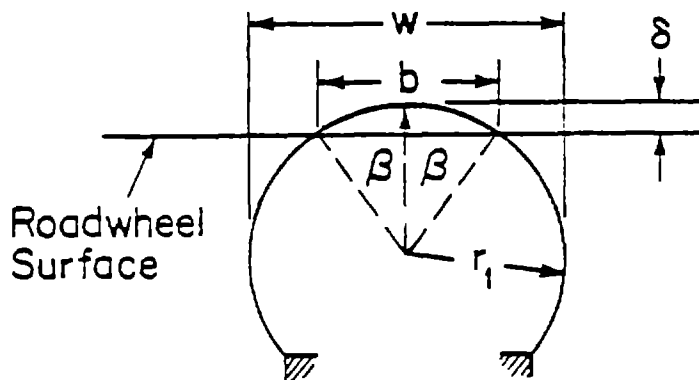

FIGURE A-6. TYPICAL TIRE CROSS-SECTIONAL GEOMETRY

Combining (A-22) and (A-23) gives

$$\frac{b}{2} = (\delta w)^{1/2} \quad (\text{A-24})$$

We now assume, as has been done in the past [3], that the load carried by the tire is the product of its contact area and inflation pressure p_0 , and further that the contact area is an ellipse of semi-major axis $L/2$ (Eq. (A-21)) and semi-minor axis $b/2$ (Eq. (A-24)). Using F_z for the tire load

$$F_z = \pi p_0 \frac{L}{2} \frac{b}{2} = \frac{\pi}{\sqrt{2}} p_0 \delta(w)^{1/2} \left(\frac{1}{r} - \frac{1}{R} \right)^{-1/2} \quad (\text{A-25})$$

or

$$\delta = \frac{\sqrt{2}}{\pi} \left(\frac{F_z}{p_0} \right) \frac{1}{\sqrt{w}} \left(\frac{1}{r} + \frac{1}{R} \right)^{1/2} \quad (\text{A-26})$$

By general consideration of linear elasticity the strain on a body is proportional to the deflection at a point divided by a characteristic length. Equation (A-26) describes the maximum deflection. For the same tire, the deflection on a flat surface would be given by Eq. (A-27).

$$\delta = \frac{\sqrt{2}}{\pi} \left(\frac{F_z}{p_0} \right) \frac{1}{\sqrt{w}} \left(\frac{1}{r} \right)^{1/2} \quad (\text{A-27})$$

If the loads, inflation pressures and geometries are the same, then the ratio of tire deflection on the drum to those on the flat surface are given by Eq. (A-28).

$$\frac{\delta_{dr}}{\delta_{fl}} = \left(1 - \frac{r}{R} \right)^{1/2} \quad (\text{A-28})$$

It is known from a great deal of test data that to a first approximation the equilibrium rolling resistance of the tire is proportional to the first power of its deflection for the same cold inflation pressure, so that it is anticipated that a ratio of rolling resistance on a drum to that on a flat surface is the same as given by Eq. (A-28).

$$F_{KR} = F_x \left(1 + \frac{r}{R} \right)^{1/2} \quad (\text{A-29})$$

This leads to the conclusion that if deflection is to be used as a criterion for loading of a tire then to the best of our present understanding the same equilibrium rolling resistance will be obtained on the drum as on a flat surface when equal tire deflections are maintained. On the other hand, if load is used as a criterion for adjusting the tire on the drum then the ratios of rolling resistance on the drum to rolling resistance on the flat surface is given by Eq. (A-29), where it is seen that the rolling resistance on the drum \bar{F}_R is greater than the corresponding rolling resistance \bar{F}_X on the flat surface by the factor $(1 - r/R)^{1/2}$.